

Panasonic®

Operating Instructions

DVD Recorder

Model No. **DMR-EZ28EB**

DIGA

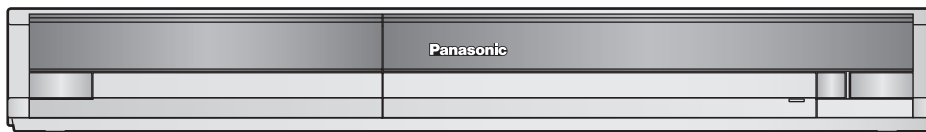

The illustrations in these Operating Instructions show images of the silver model.

Dear customer

Thank you for purchasing this product.

For optimum performance and safety, please read these instructions carefully.

Before connecting, operating or adjusting this product, please read the instructions completely.

Please keep this manual for future reference.

Note: "EB" on the packaging indicates the United Kingdom.



Trademark of the DVB Digital Video Broadcasting Project (1991 to 1996)
Declaration of Conformity No. 5137, 16th November 2007

Notice for DVB functions

This DVD Recorder is for viewing and recording free to view channels only, not Pay TV or encrypted channels unless connected to an external source capable of receiving Pay TV or encrypted channels.

This unit does not have an analogue broadcast tuner.

• This unit has the capability for DVB specifications. But future DVB services cannot be guaranteed.

Region number supported by this unit

Region numbers are allocated to DVD recorders and DVD-Video according to where they are sold.

- The region number of this unit is "2".
- The unit will play DVDs marked with labels containing "2" or "ALL".

Example:



Web Site: <http://www.panasonic-europe.com>

Features

Enjoy Digital Broadcast !

Receive Freeview using an integrated (Digital Video Broadcasting) tuner

- Watching Television (→ 16)
- TV Guide (→ 16, 19, 30)
- Register and instantly call up favourite programmes with Edit Profiles (→ 50)
- Digital Channel Information (→ 36)

Easy to Find and Select !

You can easily find programmes you want to watch and set them for timer recording.

TV Guide (→ 16, 19, 30)

TV Guide: Landscape		Mon 18/02/09 19:35	
Mon 18th	Prog. Type	Category	
All Types All Services			
19:00-20:00 Emmerdale : In today's show we will find a way...			
Time:	19:30	20:00	20:30 21:00 21:30
1 BBC1	CSI NY	DIYS.O.S.	Red Cap
2 BBC2	HotWars	Holiday Programme	
7 ITV1	Emmerd	Corotation Street	The Bill
10 Channel4	Scrapheap Challenge	Pepsi Chart Show	
31 Channel5	News	Sex in the City	Terminator2
45 ITV2	Me out of here!	Pop Idol	News
70 S4C	Rugby	15 to 1	ScrapheapChallenge
+24 Hr Prog. Type Category			

SELECT VIEW Info Page + []
RETURN Guide Change Display Mode Page - []

You can easily select and play recorded programmes.

DIRECT NAVIGATOR (→ 32)

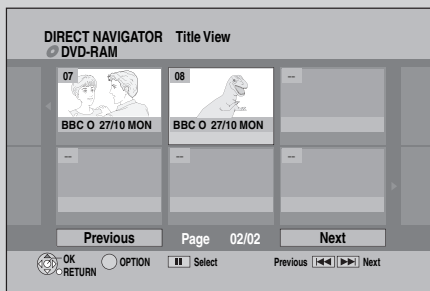

Convenient Functions !

Linked operations with the TV

You can enjoy linked operations with the TV and receiver by using VIERA Link or Q Link. Linked operations with the TV (VIERA Link "HDAVI Control™"/Q Link)(→ 38)

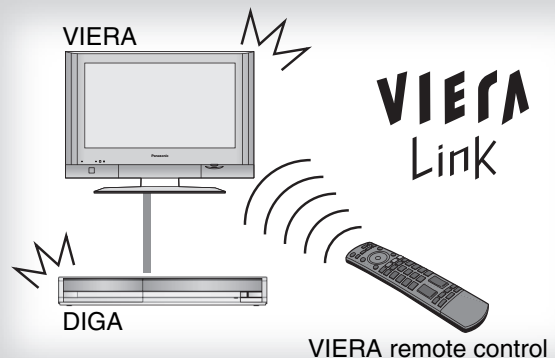

Linked timer recordings with external equipment

You can set the Timer Recordings on Digital STB/Satellite Receiver when it is connected to this unit with SCART cable. EXT LINK (→ 25)

Freeview built-in functions

Freeview built-in is a function that enables timer recordings to be controlled by the signal sent from the broadcaster, e.g., delayed recording start time. Guide Link (→ 19)

High Quality Picture

HDMI™ (V.1.3 with Deep Colour)

- Connection with HDMI terminal (→ 10)
- Deep Colour (→ 72)

Digital Switchover

Starting in late 2007 and ending in 2012, TV services in the UK will go completely digital, TV region by TV region. If you are missing any channels, it may be that they are not available in your area, or that your aerial needs upgrading.

If you have any questions, please call Digital UK on **08456 50 50 50** or visit **www.digitaluk.co.uk**. Digital Switchover will cover a period of several weeks. When it starts some Digital TV programmes will be missing.

You will need to retune your DVD Recorder each time this happens to recover your digital programmes.

To retune your DVD Recorder → "Auto-Setup Restart" in the Setup menu (→ 51)

Accessories



Please check and identify the supplied accessories. Use numbers indicated in parentheses when asking for replacement parts. (Product numbers correct as of April 2008. These may be subject to change.)



- 1 Remote control (N2QAYB000126)



- 1 RF coaxial cable (K1TWACC00001)

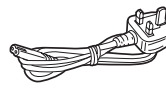

- 1 AC mains lead (K2CT3CA00004)
• For use with this unit only. Do not use it with other equipment. Also, do not use cords for other equipment with this unit.

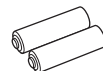

- 2 Batteries for remote control (R6 Size)



- 1 Audio/video cable (→ 59) (K2KA2BA00003)

Sales and Support Information

Customer Care Centre

- For customers within the UK: 0844 844 3852
- For customers within the Republic of Ireland: 01 289 8333
- Visit our website for product information
- E-mail: customer.care@panasonic.co.uk

Direct Sales at Panasonic UK

- For customers: 0844 844 3856
- Order accessory and consumable items for your product with ease and confidence by phoning our Customer Care Centre Monday-Thursday 9:00am-5:30pm, Friday 9:30am- 5:30pm (Excluding public holidays).

- Or go on line through our Internet Accessory ordering application at www.panasonic.co.uk.
- Most major credit and debit cards accepted.
- All enquiries transactions and distribution facilities are provided directly by Panasonic UK Ltd.
- It couldn't be simpler!
- Also available through our Internet is direct shopping for a wide range of finished products, take a browse on our website for further details.

*Interested in purchasing an extended guarantee?
Please call 0870 240 6284 or visit our website
www.panasonic.co.uk/guarantee.*



Caution for AC Mains Lead

For your safety, please read the following text carefully.

This appliance is supplied with a moulded three pin mains plug for your safety and convenience.

A 5-ampere fuse is fitted in this plug.

Should the fuse need to be replaced please ensure that the replacement fuse has a rating of 5-ampere and that it is approved by ASTA or BSI to BS1362.

Check for the ASTA mark  or the BSI mark  on the body of the fuse.

If the plug contains a removable fuse cover you must ensure that it is refitted when the fuse is replaced.

If you lose the fuse cover the plug must not be used until a replacement cover is obtained.

A replacement fuse cover can be purchased from your local dealer.

CAUTION!

IF THE FITTED MOULDED PLUG IS UNSUITABLE FOR THE SOCKET OUTLET IN YOUR HOME THEN THE FUSE SHOULD BE REMOVED AND THE PLUG CUT OFF AND DISPOSED OF SAFELY.
THERE IS A DANGER OF SEVERE ELECTRICAL SHOCK IF THE CUT OFF PLUG IS INSERTED INTO ANY 13-AMPERE SOCKET.

If a new plug is to be fitted please observe the wiring code as stated below.

If in any doubt please consult a qualified electrician.

IMPORTANT

The wires in this mains lead are coloured in accordance with the following code:

Blue: Neutral, Brown: Live.

As these colours may not correspond with the coloured markings identifying the terminals in your plug, proceed as follows:

The wire which is coloured Blue must be connected to the terminal which is marked with the letter N or coloured Black or Blue.

The wire which is coloured Brown must be connected to the terminal which is marked with the letter L or coloured Brown or Red.

WARNING: DO NOT CONNECT EITHER WIRE TO THE EARTH TERMINAL WHICH IS MARKED WITH THE LETTER E, BY THE EARTH SYMBOL \perp OR COLOURED GREEN OR GREEN/YELLOW.

THIS PLUG IS NOT WATERPROOF—KEEP DRY.

Before use

Remove the connector cover.

How to replace the fuse

The location of the fuse differ according to the type of AC mains plug (figures A and B). Confirm the AC mains plug fitted and follow the instructions below.

Illustrations may differ from actual AC mains plug.

1. Open the fuse cover with a screwdriver.

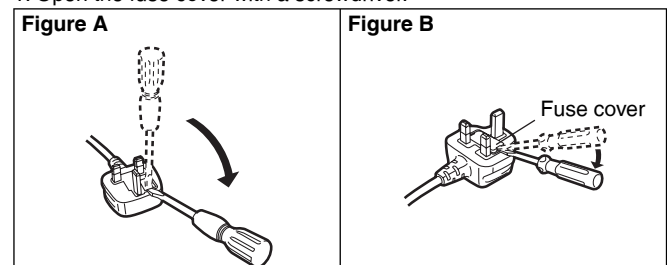

2. Replace the fuse and close or attach the fuse cover.

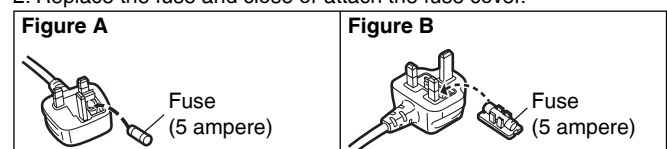

Table of Contents

Getting Started

Features	2	Caution for AC Mains Lead.....	3
Accessories	3	Remote Control Information	5
Sales and Support Information.....	3		

Quick Start Guide

Location of Parts/Controls.....	6		
Remote Control.....	6		
Main Unit.....	6		
The Unit's Display.....	7		
Rear Panel.....	7		
Basic Connection.....	8		
Connecting to a Television only.....	8		
Adding a Satellite Receiver: Connecting to a Television and a Satellite Receiver.....	9		
Connecting to a Television with an HDMI (High Definition Multimedia Interface) Cable.....	10		
Setting the Channels and Clock.....	11		
Clock Setting.....	12		
Disc Handling	13	Advanced Playback	32
Usable Discs for Recording and Playback	13	Selecting Titles to Play.....	32
Disc Care	13	Search.....	32
Play-only Discs.....	14	Skip.....	32
Discs that Cannot be Played.....	14	Direct Play.....	32
Types of disc for the type of connected TV.....	14	Quick View (Play x1.3).....	32
Inserting Discs.....	14	Slow-motion Play.....	33
MP3s and Still Pictures (JPEG).....	15	Frame-by-Frame Viewing.....	33
MP3 File Information.....	15	Time Slip.....	33
Still Picture (JPEG) Information.....	15	Manual Skip.....	33

Basic Operations

Watching Television	16	Create Chapters.....	33
Watching Satellite Programmes.....	16	Playing Still Pictures (JPEG), MP3.....	34
Playback.....	17	Playing Still Pictures (JPEG).....	34
Playing Discs.....	17	Playing MP3s.....	35
Recording Television Programmes.....	18	Information Messages.....	36
Timer Recording.....	19	Digital Channel Information.....	36
Deleting Titles.....	20	Status Messages.....	37
Delete Navigator.....	20	New Service Message.....	37
Delete Titles During Playback.....	20	FUNCTION MENU Window.....	37

Advanced Features

Important Notes for Recording	21	Easy control only with VIERA remote control.....	39
Advanced Recording.....	22	Linked Operations with the TV (VIERA Link "HDAVI Control™"/Q Link).....	38
Recording Modes and Durations.....	22	Easy control only with VIERA remote control.....	39
When the format confirmation screen is displayed.....	23	Advanced Editing.....	
When removing a Recorded Disc.....	23	Entering Text.....	40
Specifying the Recording Time.....	23	Titles-Editing.....	40
Direct TV Recording.....	23	Accessing the Title View.....	40
Flexible Recording.....	24	Title Operations.....	41
Playing while you are recording.....	24	Chapters-Creating, Editing.....	43
Recording from a Satellite Receiver.....	25	Accessing the Chapter View.....	43
Manual Recording.....	25	Chapter Operations.....	43
Linked timer recordings with external equipment (SKY Digital STB/satellite receiver)-EXT LINK.....	25	Creating, Editing and Playing Playlists.....	44
Recording from an External Device.....	26	Accessing the Playlist View.....	44
Recording from a VCR, etc.....	26	Creating Playlists.....	44
Recording from a DV Camcorder.....	26	Editing Playlists/Chapters.....	44
Advanced Timer Recording.....	27	Setting Menus.....	
Manual timer recordings.....	27	Setting On-Screen Display.....	46
To cancel a timer recording in progress.....	28	Accessing the On-Screen Display.....	46
To deactivate timer programme (e.g. to interrupt a daily or weekly timer programming).....	28	DVD Management.....	48
Check, Change, or Delete Programmes.....	29	Accessing the Management Menus.....	48
Notes on timer recording.....	29	Setup Menu.....	50
Making timer recordings on the television.....	29	Accessing the Setup Menu.....	50
TV Guide.....	30	Channel Settings.....	50
Using the TV Guide.....	30	Playback/Recording Settings.....	52
Selecting the programme from the desired programme type or category.....	31	Picture Settings.....	52
		Sound Settings.....	53
		Display and Connection Settings.....	54
		System Settings.....	56

Other Settings

Other Settings.....	57
Child Lock	57
Using the Unit's Remote Control to Operate the TV.....	57

Reference

Additional Connections.....	58
Adding a VCR: Connecting to a Television and a Video Cassette Recorder	58
Using an Audio/Video Cable	59
Using an S Video Cable	59
Using Component Video Cables	59
Using an Audio Cable for Better Sound	60
Using an Optical Digital Audio Cable for Better Sound	60
Connecting with an HDMI (High Definition Multimedia Interface) Cable	60

Frequently Asked Questions 61

Setup	61
Discs	61
Recording	62
TV Guide	62
DVB-T	62
Messages	63
On the Unit's Display	63
On the TV	64
Unit Care	64

Troubleshooting Guide 65

When Other Panasonic Products Respond to this Remote Control.....	65
To reset this unit	65
General Issues: Power	66
General Issues: Displays	66
General Issues: Operation	66
General Issues: VIERA Link	67
General Issues: DVB-T	67
General Issues: TV Guide	68
Playback Issues: Sound	68
Playback Issues: Picture	69
Playback Issues: Operation.....	70
Recording Issues: Recording / Timer recording / External input ...	70
Editing Issues: DVD.....	71
Glossary	72
Safety precautions	73
Specifications	74
Index.....	Back cover

About batteries

- Insert so the poles (+ and -) match those in the remote control.
- Do not use rechargeable type batteries.

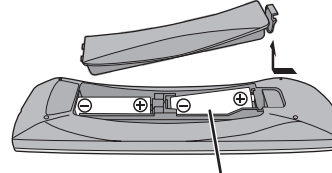

R6/LR6, AA

- Do not mix old and new batteries.
- Do not use different types at the same time.
- Do not heat or expose to flame.
- Do not leave the batteries in an automobile exposed to direct sunlight for a long period of time with doors and windows closed.
- Do not take apart or short circuit.
- Do not attempt to recharge alkaline or manganese batteries.
- Do not use batteries if the covering has been peeled off.

Mishandling of batteries can cause electrolyte leakage which can damage items the fluid contacts and may cause a fire.

Remove if the remote control is not going to be used for a long period of time. Store in a cool, dark place.

Using the remote control

Aim at the sensor, avoiding obstacles, up to a maximum range of 7 m directly in front of the unit.

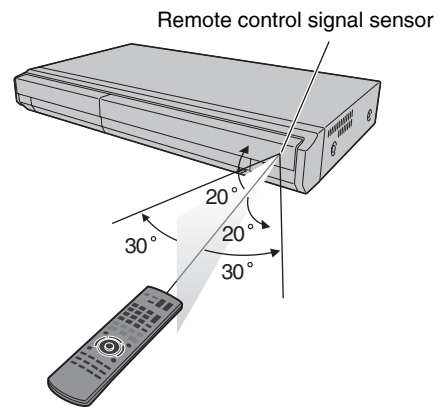

Location of Parts/Controls

Remote Control

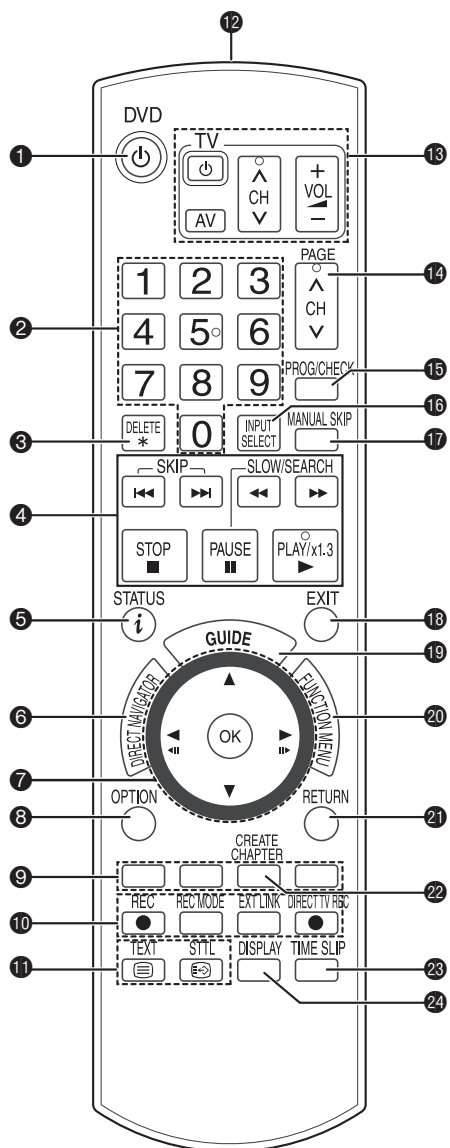

- 1 Turn the unit on or off..... (→ 11)
- 2 Select channels and title numbers etc./
Enter numbers (→ 11)
- 3 Delete items..... (→ 20)
- 4 Basic operations for recording and play
- 5 Show the digital channel information/
Programme information within TV Guide screen/
Show status messages..... (→ 30, 36, 37)
- 6 Show DIRECT NAVIGATOR..... (→ 32, 34)
- 7 Selection/OK, Frame-by-frame (→ 11, 33)
- 8 Show OPTION menu..... (→ 34, 40, 43)
This menu is used when playing or editing titles and playing still pictures, etc.
- 9 Use Colour buttons according to on-screen instructions.
These buttons are for TV Guide/Digital TEXT/Edit Profiles.
In addition,
"Red": Timer recording list
"Blue": Digital channel information/Timer recording list
- 10 Recording function
[● REC]: Start recording (→ 18)
[REC MODE]: Change recording mode (→ 18)
[EXT LINK]: Linked timer recordings with external equipment (→ 25)
[● DIRECT TV REC]: Direct TV recording..... (→ 23)
- 11 DVB function
[TEXT (☺)]: Show Digital TEXT (MHEG) service (→ 36)
[STTL (☺)]: Show subtitles (→ 36)
- 12 Transmission window
- 13 TV operations (→ 57)
- 14 Channel select/Change pages in the
TV Guide list (→ 18, 30)
- 15 Show timer recording list (→ 27)
- 16 Input select (Tuner, AV1, AV2, AV3, DV) (→ 16, 25, 26)
- 17 Skip approx. 1 minute forward (→ 33)
- 18 Exit the menu screen
- 19 Show the TV Guide screen..... (→ 16, 19, 30)
- 20 Show FUNCTION MENU window (→ 37)
By using the FUNCTION MENU window you may access the main
functions (Playback, Recording, etc.) quickly and easily.
- 21 Return to previous screen
- 22 Create chapters (→ 33)
- 23 Skip the specified time..... (→ 33)
- 24 Show menu for disc playback etc./
Change DVB multi audio (→ 46)

Main Unit

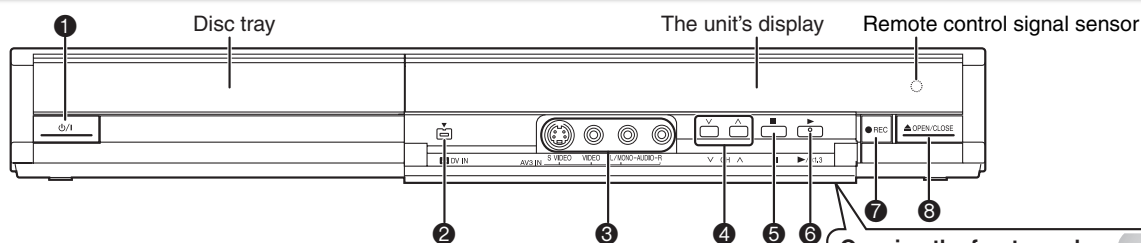

Opening the front panel
Press down on the  part
with your finger.

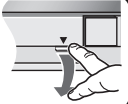

- 1 **Standby/on switch** (⏻/⏻) (→ 11)
• Press to switch the unit from on to standby mode or vice versa. In standby mode, the unit is still consuming a small amount of power.
- 2 DV IN terminal (for a digital video camcorder)..... (→ 26)
- 3 AV3 input terminals..... (→ 26)
- 4 Channel Select button (→ 18)
- 5 Stop button (→ 17, 18)
- 6 Play/X1.3 button (→ 17)
- 7 Start recording button (→ 18)
- 8 Disc tray open/close button (→ 14, 17)

The Unit's Display

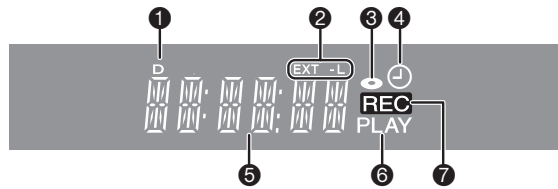

- 1** Digital broadcast indicator
Lights while the unit is receiving digital broadcast or TV Guide data.
- 2** Linked timer recordings with external equipment indicator (→ 25)
- 3** Disc indicator
This indicator lights up when a disc that is supported by this unit is inserted.
- 4** Timer recording indicator..... (→ 19)
On:
When a timer recording programme is registered and a recordable disc is inserted.
Flashes:
The timer recording indicator flashes when the unit cannot go to timer recording standby (e.g. there is no disc, etc.).
- 5** Main display section
Current time/playback counter, various messages.
- 6** Playback indicator
- 7** Recording indicator

Rear Panel

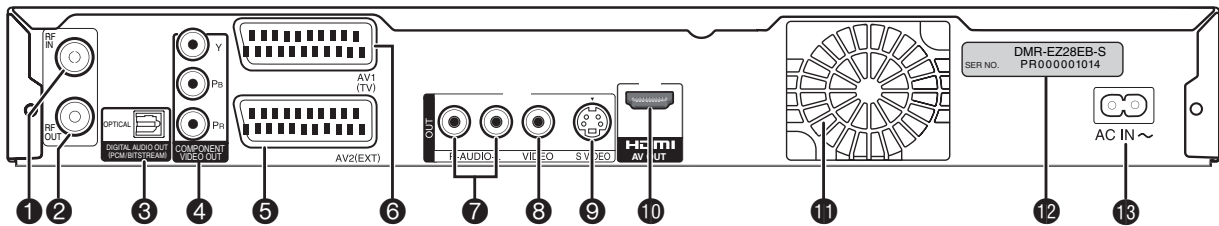

- 1** Aerial input terminal..... (→ 8, 9, 58)
- 2** Aerial output terminal (→ 8, 9, 58)
- 3** Digital audio output terminal..... (→ 60)
- 4** COMPONENT VIDEO OUT (PROGRESSIVE/INTERLACE) terminals (→ 59)
Y = Luminance signal (brightness), P_B = Chrominance signal (colour difference), P_R = Chrominance signal (colour difference)
- 5** AV2 (EXT) 21-pin Scart terminal..... (→ 9, 58)
Connection of an external unit
- 6** AV1 (TV) 21-pin Scart terminal (→ 8, 9, 58)
TV set connection
- 7** AUDIO output terminals..... (→ 59, 60)
- 8** Video output terminal..... (→ 59)
- 9** S VIDEO output terminal (→ 59)
- 10** HDMI AV OUT terminal (→ 10, 60)
Digital audio and video output terminal
- 11** Cooling fan
- 12** Serial number
- 13** AC IN~ = Power supply
Connection for the AC mains lead

21-pin Scart terminal

The 21-pin Scart terminal transmits both input and output signals for picture and sound. TVs equipped with the same type of terminal can be connected here. This type of terminal is also called Peritel, Euro Connector and Euro AV.

- When the unit is connected to a Q Link-compatible TV with a fully wired 21-pin Scart cable, you can use convenient functions of Q Link.

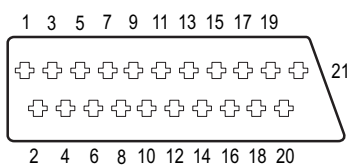

AV1 Scart terminal (TV)

- 1 Audio output CH2 (R)
- 2 Audio input CH2 (R)
- 3 Audio output CH1 (L)
- 4 Audio ground
- 5 Blue ground
- 6 Audio input CH1 (L)
- 7 Blue output
- 8 Switching voltage output
- 9 Green ground
- 10 Q Link control signal
- 11 Green output
- 12 Reserved
- 13 Red ground
- 14 Blanking ground
- 15 Red output / chrominance output
- 16 Blanking output
- 17 Video output ground
- 18 Video input ground
- 19 Video output / luminance output
- 20 Video input
- 21 Ground

AV2 Scart terminal (EXT)

- 1 Audio output CH2 (R)
- 2 Audio input CH2 (R)
- 3 Audio output CH1 (L)
- 4 Audio ground
- 5 Blue ground
- 6 Audio input CH1 (L)
- 7 Blue input
- 8 Switching voltage input
- 9 Green ground
- 10 Reserved
- 11 Green input
- 12 Reserved
- 13 Red ground
- 14 Blanking ground
- 15 Red input / chrominance input
- 16 Blanking input
- 17 Video output ground
- 18 Video input ground
- 19 Video output
- 20 Video input / luminance input
- 21 Ground

Basic Connection

Use of the RF coaxial cable

- Keep the RF coaxial cables as far away as possible from other cables.
- Do not roll up the RF coaxial cables.

Before connection, turn off the mains for all connected equipment and read the appropriate operating instructions.

Be sure to read the Caution for AC Mains Lead on page 3.

Connecting to a Television only

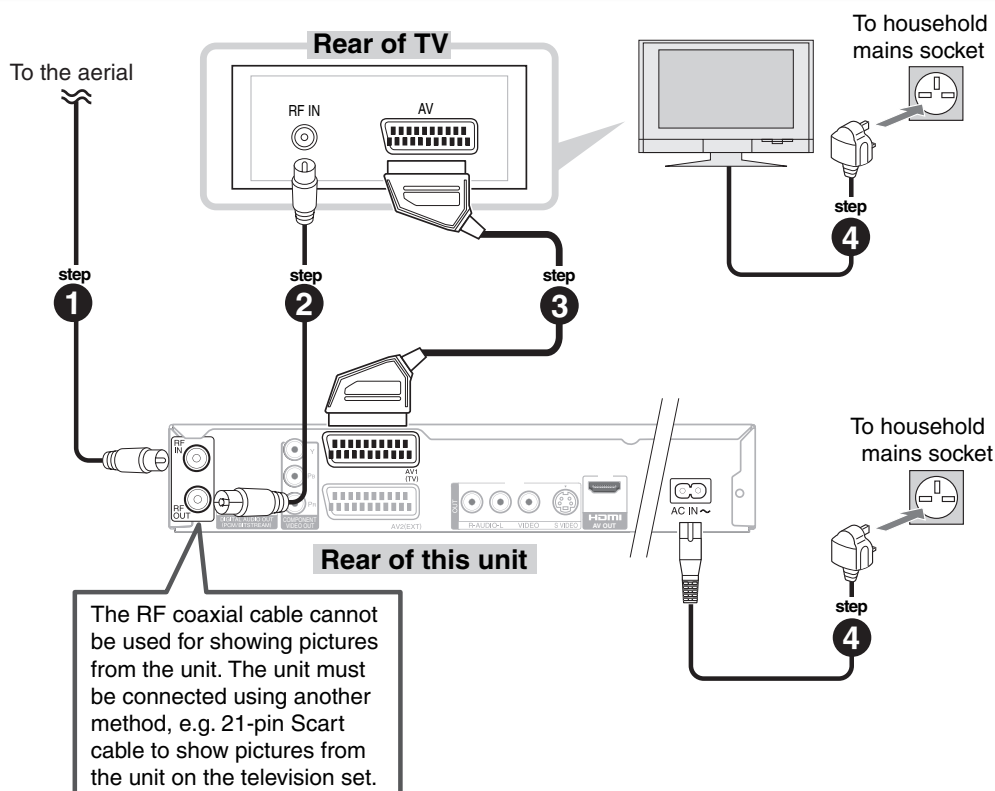

Connections other than the 21-pin Scart cable ▶59

- 1 Aerial cable to the "RF IN" on the unit.
- 2 RF coaxial cable (supplied) from the "RF OUT" on the unit to the "RF IN" on the TV.
- 3 21-pin Scart cable (not supplied) from the "AV1 (TV)" on the unit to the "AV" on the TV.
- 4 AC mains lead (supplied) from the "AC IN~" on the unit and the TV to a household mains socket.

After completing the above connections, proceed to the TV Tuning (→ 11).

Using a fully wired 21-pin Scart cable

- You can use a variety of Q Link functions by connecting the unit to a Q Link compatible television (→ 38).
- You can enjoy high-quality viewing by connecting the unit to an RGB compatible television.
- “AV1 Output” in the Setup menu is set to “RGB 1 (without component)” or “RGB 2 (without component)” (→ 55).
- “AV2 Input” settings in the Setup menu (→ 55)

Before connection, turn off the mains for all connected equipment and read the appropriate operating instructions.

Be sure to read the Caution for AC Mains Lead on page 3.

Adding a Satellite Receiver: Connecting to a Television and a Satellite Receiver

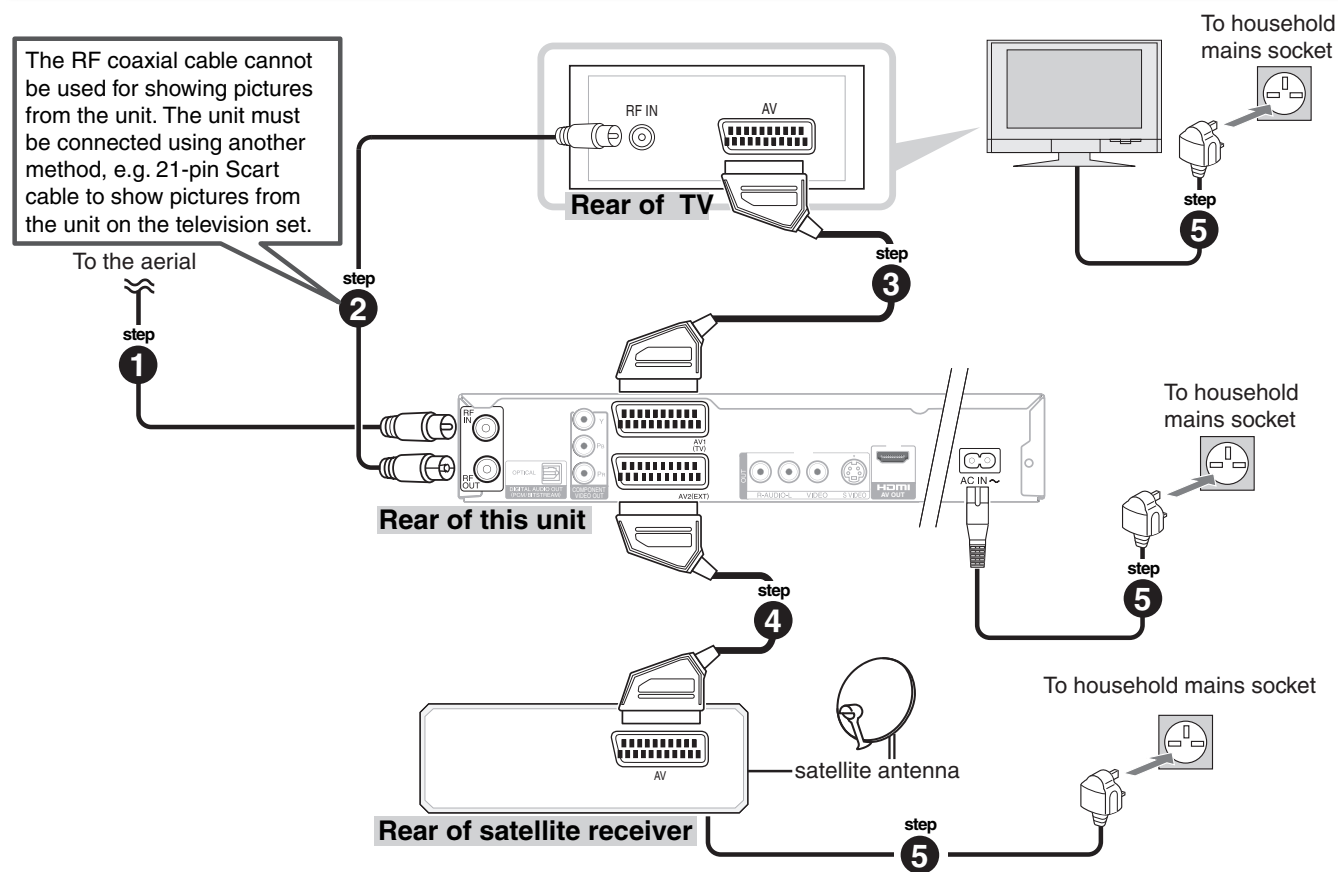

Connections other than the 21-pin Scart cable ▶ 59

- 1 Aerial cable to the “**RF IN**” on the unit.
- 2 RF coaxial cable (supplied) from the “**RF OUT**” on the unit to the “**RF IN**” on the TV.
- 3 21-pin Scart cable (not supplied) from the “**AV1 (TV)**” on the unit to the “**AV**” on the TV.
- 4 21-pin Scart cable (not supplied) from the “**AV**” on the satellite receiver to the “**AV2 (EXT)**” on the unit.
- 5 AC mains lead (supplied) from the “**AC IN~**” on the unit, the TV and the satellite receiver to a household mains socket.

After completing the above connections, proceed to the TV Tuning (→ 11).

To view satellite programmes

Refer to “Watching Satellite Programmes” (→ 16).

To record satellite programmes

Refer to “Recording from a Satellite Receiver” (→ 25).

Basic Connection

You can enjoy high-quality picture by adding the HDMI cable connection to the 21-pin Scart cable connection between the unit and your TV on page 8, 9.

Connecting to a Television with an HDMI (High Definition Multimedia Interface) Cable

When connected to an HDMI compatible unit, an uncompressed digital audio and video signal is transmitted, enabling you to enjoy high quality, digital video and audio with just one cable. When connecting to an HDMI-compatible HDTV (High Definition Television), the output can be switched to 1080p, 1080i or 720p HD video.

• **This unit incorporates HDMI™ (V.1.3 with Deep Colour) technology** that can reproduce greater colour gradation (4096 steps) when connected to a compatible TV.

A lower colour gradation (256 steps), without deep colour, will be reproduced if connected to a TV which does not support deep colour.

The unit will automatically set appropriate output to suit the connected TV.

- Video sources converted to 1920 × 1080 resolution, while of high quality, will exhibit somewhat lower subjective image resolution than true, native 1080p full-HD sources. See dealer for details.
- Please use High Speed HDMI Cables that have the HDMI logo (as shown on the cover).
- When outputting 1080p signal, please use the HDMI cables 5.0 meters or less.

Regarding VIERA Link “HDAVI Control™” function

When connecting with a Panasonic TV (VIERA) or a receiver equipped with the “HDAVI Control” function, linked operations would be possible. [→ 38, Linked Operations with the TV (VIERA Link “HDAVI Control™”/Q Link)]

- This unit incorporates HDMI™ (V.1.3 with Deep Colour) technology.
- It is recommended that you use Panasonic’s HDMI cable.

Recommended part number: RP-CDHG10 (1.0 m), RP-CDHG15 (1.5 m), RP-CDHG20 (2.0 m), RP-CDHG30 (3.0 m), RP-CDHG50 (5.0 m), etc.

- Non-HDMI-compliant cables cannot be utilized.

Connecting with a Panasonic TV (VIERA)

If the 21-pin Scart cable (not supplied) is connected, the following functions are available.

- Direct TV Recording (→ 23)
- Watching pictures from satellite receiver (→ 16)

(In this case, make sure to switch the television input to “AV”.)

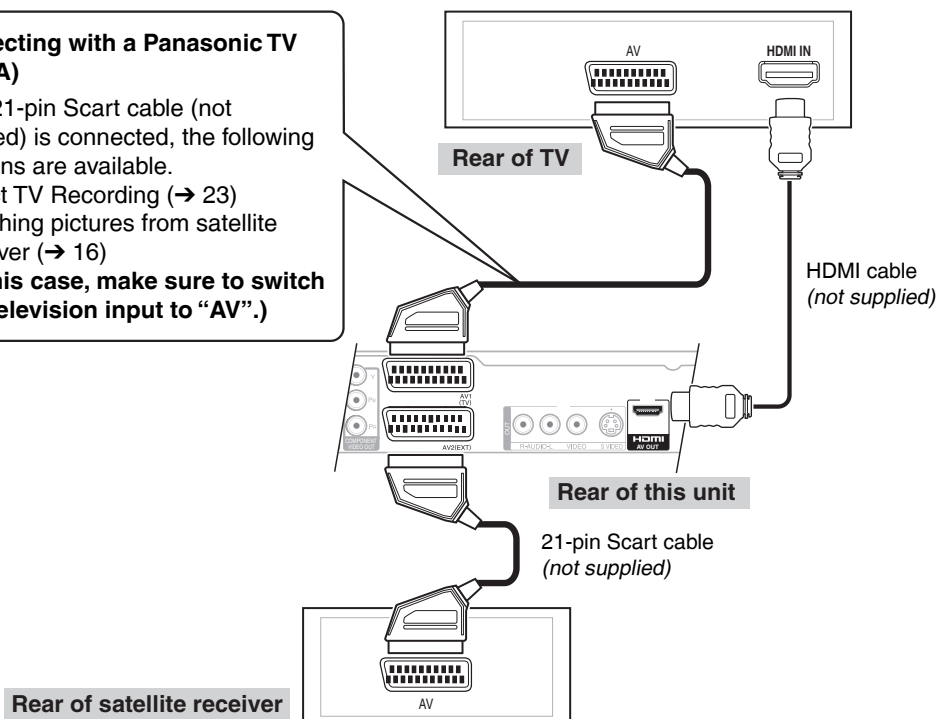

- Set “Digital Audio Output” to “HDMI and Optical” (→ 55). (The default setting is “HDMI and Optical”.)

To enjoy High Quality Video up-converted to 1080p, you need to connect the unit to 1080p compatible HDTV and set “HDMI Video Format” in the Setup menu to “1080p” (→ 55).



Notes

- If connecting to equipment that is only audio compatible with 2 channels audio output, audio with 3 channels or more will be down-mixed (→ 72) and output as 2 channels, even if connecting with an HDMI cable (some discs cannot be down-mixed).
- For display units compatible with HDCP (High-Band width Digital Content Protection) that are equipped with a digital DVI input terminal (PC monitors, etc.):
Depending on the unit, picture may not display properly or at all when connecting with a DVI/HDMI switching cable (audio cannot be output).

Setting the Channels and Clock

Preparation:

- Turn on the mains for the television (and connected equipment) and select the appropriate AV input to suit the connections to this unit.
- These are the first settings you make upon buying the unit. You don't need to make these settings again.



TV's remote control

1 to turn the unit on.

DVB Auto-Setup starts. The unit will search for the digital terrestrial channels. This takes about 5 minutes.

- TV channels are sorted and stored in channel numbers order sent by the broadcasters and cannot be changed.

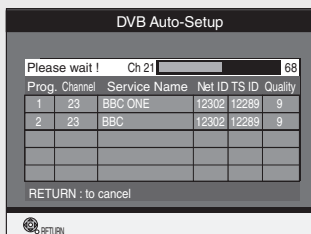

2 Power Save Function:

to select "On" or "Off", then .

- Set to "On" to reduce power consumption in standby mode.
- Refer to the following chart for the Power Save function features when the unit is turned off.

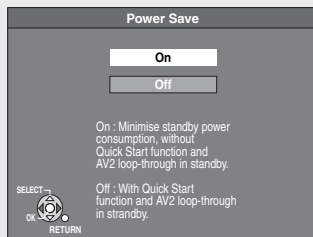

Power Save	On	Off
Power consumption	Approx. 2 W	Approx. 15 W
Watching the picture from the satellite receiver connected to the AV2 input terminal	Can not do	Can do
Startup time	Not quick	Quick*
Front display	Turns off (The clock display disappeared.)	Stays lighted

* e.g., TV Guide is displayed within 1 second after [GUIDE] is pressed while the unit is off.

3 When setup has completed, the confirmation screen appears.



4 The Owner ID settings screen appears. and press the numbered buttons to enter your choice of a 4-digit PIN number.

Make a note of the PIN number (don't forget), as it is not possible to return to the factory preset.

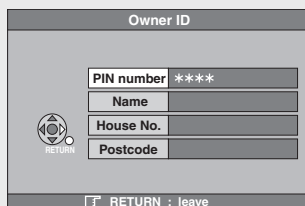

5 to store the PIN number.

(continued on the next page)

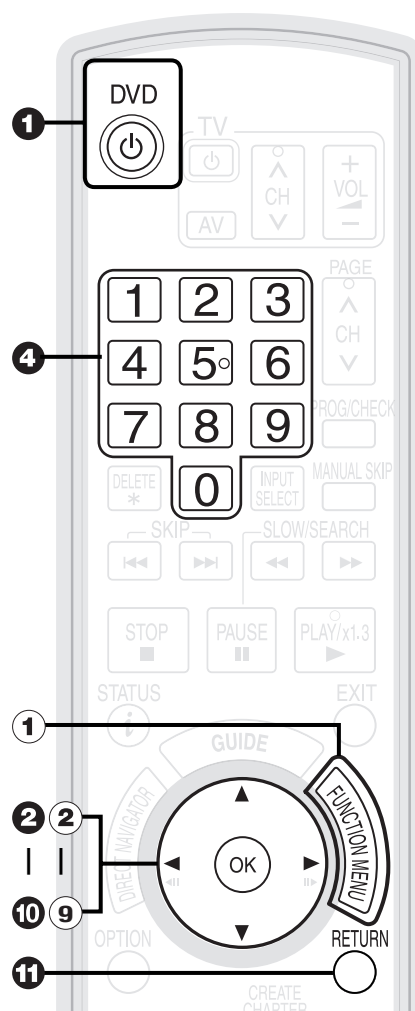

Tips

To cancel Auto-Setup
Press [RETURN].

- **If the unit displays "No stations found !"**
Press to select "No" and press [OK]. Go to step 2. After you have performed steps 2 - 11, turn off the unit and confirm the cable or aerial input is connected to the RF IN terminal. Restart the Auto-Setup again (→ 51).
- If the clock setting menu appears or the clock is not correct, set the clock manually (→ 12).

Restarting the Auto-Setup (→ 51)

To correct the PIN number

1. Press to select the digit.
2. Press the numbered buttons to enter the digit.

Setting the Channels and Clock

6 ◀ to select “Yes”, then 
The cursor moves to “Name”.

7 ▶ to enter the name.

8 ▲, ▼ to select a letter, then ▶ to move to next character.
Repeat this to enter the name.

9  to store the name.

10 ▼ and ▶ and then repeat steps 8, 9 to enter and store “House No.” and “Postcode”.

11 
The Owner ID settings screen disappears.

- Auto-Setup for your unit is complete. You can now make your favourite channels and store them in the required order in the profiles (→ 50).

Tips

To correct the character

1. Press [◀, ▶] to select the character.
2. Press [▲, ▼] to correct the character.

To display the Owner ID information on TV

Press and hold [■] on the main unit for more than 5 seconds.
The PIN number is not displayed.
After 30 seconds this menu automatically disappears.

Clock Setting

This unit usually obtains time and date information from digital broadcasts and automatically corrects the time several times a day.

However, if the clock is not set correctly, adjust the clock.

- In the case of a power failure, the clock setting remains in memory for approximately 60 minutes.

1 With the unit stopped



2 ▲, ▼ to select “To Others”, then 

3 ▲, ▼ to select “Setup”, then 

4 ▲, ▼ to select “Others”, then ▶.

5 ▲, ▼ to select “Clock”, then 

6 ▲, ▼ to select “Off” of “Automatic”, then 

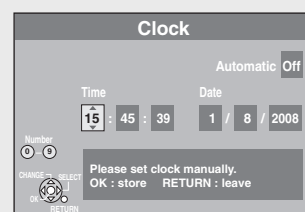

7 ◀, ▶ to select the item you want to change.

The items change as follows:

Hour ↔ Minute ↔ Second ↔ Day ↔ Month ↔ Year
↑ ↓

8 ▲, ▼ to change the setting.

You can also use the numbered buttons for setting.

9  to confirm new date and time and to initiate the clock.

Tips

To return to the previous screen

Press [RETURN].





To exit the screen

Press [EXIT].

Notes

If a TV station transmits a time setting signal, and when “Automatic” in the Clock setting menu is set to “On”, the automatic time correction function checks the time and if necessary it is adjusted several times every day.

Usable Discs for Recording and Playback

Disc type	Rewritable	Play on other players ^{※1}	Recording 16:9 aspect picture ^{※2}	Copy-once recording (CPRM) (→ 21)	Standard symbol
DVD-RAM 	○	○	○	○ CPRM (→ 72) compatible discs only.	RAM
DVD-R 	—	○	○	—	-R before finalisation DVD-V after finalisation
DVD-R DL 	—	○	○	—	-R DL before finalisation DVD-V after finalisation
DVD-RW 	○	○	○	—	-RW(V) before finalisation DVD-V after finalisation
+R	—	○	— (4:3 aspect)	—	+R before finalisation DVD-V after finalisation
+R DL	—	○	— (4:3 aspect)	—	+R DL before finalisation DVD-V after finalisation
+RW	○	○	— (4:3 aspect)	—	+RW

○: Can do, —: Cannot do

※1 **-R -R DL -RW(V) +R +R DL**

Finalisation needed for playback on other equipment (→ 49).

RAM can be played back on Panasonic DVD recorders and DVD-RAM compatible DVD players.

-R DL, +R DL or **+RW** can be played back only on equipment compatible with these discs.

※2 For further information (→ 21, Important Notes for Recording).

- **RAM -RW(V) +R +R DL +RW** To use a new disc, formatting is necessary (→ 48).
- **+RW** If the disc failed to play on other equipment, we recommend you create top menu (→ 49).
- Use of Panasonic discs is recommended.
For available recording times for different discs under different recording modes, see “Recording Modes and Durations” on page 22. Formatting and/or recording/initializing constraints may prevent you from playing or recording certain discs.
- Please see specifications (→ 74) for compatible disc versions and recording speeds.



Notes

- **RAM** will show an increase in available space whenever a title has been erased.
- **-RW(V)** and **+RW** discs will only show an increase in available space when their last title has been erased.
- **-R -R DL +R +R DL** The discs will show no increase in available space after deleting titles.
- You may not be able to record depending on the condition of the discs and you may not be able to play them due to the condition of the recording.

Disc Care

RAM Use cartridges to protect them from scratches and dirt.

Holding a disc

Handle discs by the edges to avoid inadvertently scratching or getting oil from your fingers on the disc. Do not touch the signal surface of discs (the shiny side).

Cleaning discs

Discs are not indestructible and occasionally dirt or condensation may appear. Clean by gently wiping with a soft, dry lint-free cloth in a straight line from the centre of the disc to the edge of the disc. Return discs to their cases when not in use; this helps to protect against scratches and dirt.

Storing discs

Do not place or store discs in the following locations:







- Direct sunlight
- Very dusty or humid areas
- Near a heat source
- Places that undergo extreme shifts in temperature (condensation can occur)
- Where static electricity or electromagnetic waves occur

Discs to avoid

- Discs that are not perfectly circular in shape
- Warped discs, which may not balance properly in your unit, causing improper operation or damage to the unit
- Cracked discs
- Discs with exposed adhesive (from removed stickers or labels, such as may occur with rental discs or improperly cared-for discs that were previously labeled or re-labeled)

Disc Handling

Play-only Discs

Disc type	Standard symbol	Uses
DVD-Video 	DVD-V	High quality movie and music discs
DVD-RW (DVD Video Recording format) 	-RW(VR)	DVD-RW video recorded on another DVD recorder* <ul style="list-style-type: none"> You can play programmes that allow "One time only recording" if they have been recorded onto a CPRM compatible disc. By formatting (→ 48) the disc, you can record onto it in DVD-Video format. It may be necessary to finalise the disc on the equipment used for recording.
DVD-R 	-R	<ul style="list-style-type: none"> DVD-R* and DVD-R DL* with music recorded in MP3 (→ 15) DVD-R* and DVD-R DL* with still pictures recorded in JPEG (→ 15)
DVD-R DL 	-R DL	
Audio CD 	CD	<ul style="list-style-type: none"> CD-R* and CD-RW* with music recorded in MP3 (→ 15) CD-R* and CD-RW* with still pictures recorded in JPEG (→ 15) Recorded audio and music (including CD-R/RW*)
Video CD 	VCD	Recorded music and video
SVCD 		Capable of playing discs that conform to IEC62107 only.

* Play may be impossible on some DVD-RW (DVD Video Recording format), DVD-R, DVD-R DL, CD-R or CD-RW discs due to the condition of the recording.

- You can play still pictures (JPEG) and MP3 format data recorded on DVD-R, DVD-R DL or CD-R/RW. You can also play CD-DA, Video CD and SVCD (conforming to IEC62107) format data recorded on CD-R/RW. Close the session or finalise the disc after recording.
- The producer of the disc can control how discs are played. So you may not always be able to control play as described in these operating instructions. Read the disc's instructions carefully.

Inserting Discs

- Press [▲ OPEN/CLOSE] to open the tray.
– Insert a disc.

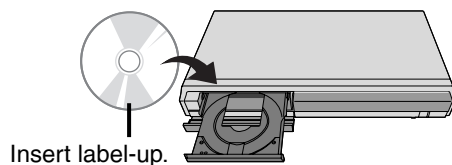

- Press [▲ OPEN/CLOSE] to close the tray.

Discs that Cannot be Played

- 2.6/5.2 GB DVD-RAM, 12 cm
- 3.95/4.7 GB DVD-R for Authoring
- DVD-R, DVD-R DL, DVD-RW, +R, +R DL recorded on another unit and not finalised (→ 72)
- Discs recorded with AVCHD format
- DVD-Video with a region number other than "2" or "ALL"
- Blu-ray, HD DVD
- DVD-Audio
- DVD-ROM, +R 8 cm, CD-ROM, CDV, CD-G, Photo CD, CVD, SACD, MV-Disc, PD, DivX Video Disc

Types of disc for the type of connected TV

When you use the discs recorded either PAL or NTSC, refer to this table.

(O: Possible to view, -: Impossible to view)

TV type	Disc	Yes/No
Multi-system TV	PAL	O
	NTSC	O
PAL TV	PAL	O
	NTSC	O*1 (PAL60)
NTSC TV	PAL	-
	NTSC	O*2

*1 If your television is not equipped to handle PAL 525/60 signals the picture will not be shown correctly.

*2 Select "NTSC" in "TV System" (→ 55).



Notes

- When using 8 cm DVD-RAM or 8 cm DVD-R, remove the disc from the cartridge.
- It is not possible to record or play continuously from one side of a double sided disc to the other. You will need to eject the disc and turn it over.

MP3s and Still Pictures (JPEG)

MP3 File Information

Playable discs	-R -R DL CD
File format	MP3 Files must have the extension “.mp3” or “.MP3”.
Number of folders (groups)	Maximum number of folders (groups) recognizable: 300 folders (groups) (including the root folder)
Number of files (tracks)	Maximum number of files (tracks) recognizable*1: 3000 files (tracks)
Bit rates	32 kbps to 320 kbps
Sampling frequency	16 kHz/22.05 kHz/24 kHz/ 32 kHz/44.1 kHz/48 kHz
ID3 tags	not compatible

- If there is a large amount of still picture data etc. within an MP3 file, play may not be possible.

Still Picture (JPEG^{※2}) Information

Playable discs	-R -R DL CD
File format	JPEG Files must have the extension “.jpg” or “.JPG”.
Number of pixels	between 34×34 and 6144×4096 (Sub sampling is 4:2:2 or 4:2:0)
Number of folders ^{※3}	Maximum number of folders recognizable: 300 folders (including the root folder)
Number of files ^{※3}	Maximum number of files recognizable*1: 3000 files

MOTION JPEG not compatible

- If there is a large amount of still picture data etc. within an MP3 file, play may not be possible.

※1 Total number of recognizable file including MP3, JPEG and other type of files is 4000.

※2 It may take a few moments for still pictures to display.

※3 When there are many files and/or folders, some files may not display or be playable.



Notes

- Compatible formats: ISO9660 level 1 or 2 (except for extended formats) and Joliet
- This unit is compatible with multi-session; however, reading or play of the disc may take time if there are a lot of sessions.
- Operation may take time to complete when there are many files (tracks) and/or folders (groups); some files (tracks) may not display or be playable.
- Images recorded at a very high resolution may take a long time to display.
- English alphabetical characters and Arabic numerals are displayed correctly. Other characters may not display correctly.
- The display order on this unit may differ from how the order is displayed on a computer.
- Depending on how you create the disc (writing software), files (tracks) and folders (groups) may not play in the order you number them.
- This unit is not compatible with packet-write format.
- Depending on the recording conditions, the disc may not play.



Tips

You can play MP3s and still pictures (JPEG) on this unit by making folders as shown below. However depending on the method of writing data (writing software), play may not be in the order you number the folders.

Structure of MP3 folders

-R -R DL CD

Prefix with 3-digit numbers in the order you want to play them.

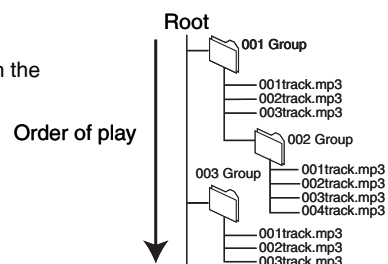

Structure of still pictures (JPEG)

-R -R DL CD

Files inside a folder are displayed in the order they were updated or taken.

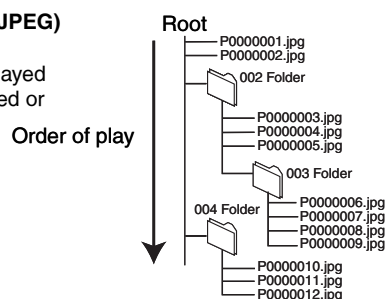

Watching Television

Refer to “TV Guide” (→ 30) for detail information.



Preparation:

Turn on the television and select the appropriate video input to suit the connections to this unit.

This DVD recorder has a tuner which allows it to directly receive and record digital terrestrial channels.



Important:

This unit does not have an analogue broadcast tuner.

1  **DVD**
1  to turn the unit on.

2  **GUIDE**
 – The TV Guide list appears.

TV Guide: Landscape				Mon 18/03/18:35
Time	Prog. Type	Category		
Mon 18th				All Services
19:00-20:00	Emmerdale	In today's show we will find a way...		
Time:	19:30	20:00	20:30 21:00 21:30	
1	BBC1	CSI NY	DIYS.O.S. Red Cap	
2	BBC2	HotWars	Holiday Programme	
7	ITV1	Fmmert	Coronation Street The Bill	
10	Channel4	Scrapheap Challenge	Pepsi Chart Show	
31	Channel5	News	Sex in the City Terminator2	
45	ITV2	Mo out of here!	Pop Idol News	
70	S4C	Rugby	T5 to 1 ScrapheapChallenge	

3  **▲**,  **▼** to select the current programme, then  **OK**

Selecting a Channel without TV Guide

To select desired channel

Press [**▲**, **▼** CH].

To directly enter Channels



You can also select channels with the numbered buttons.

e. g., “5”: [0] → [0] → [5] or [5] → [OK]
 “15”: [0] → [1] → [5] or [1] → [5] → [OK]

Watching Satellite Programmes

Preparation:

- Connect a satellite receiver to this unit's input terminals (→ 9).
- Turn on the satellite receiver.
- Turn on the television and select the appropriate video input to suit the connections to this unit.

1  **DVD**
1  to turn the unit on.

2  **INPUT SELECT** to select “AV2”.

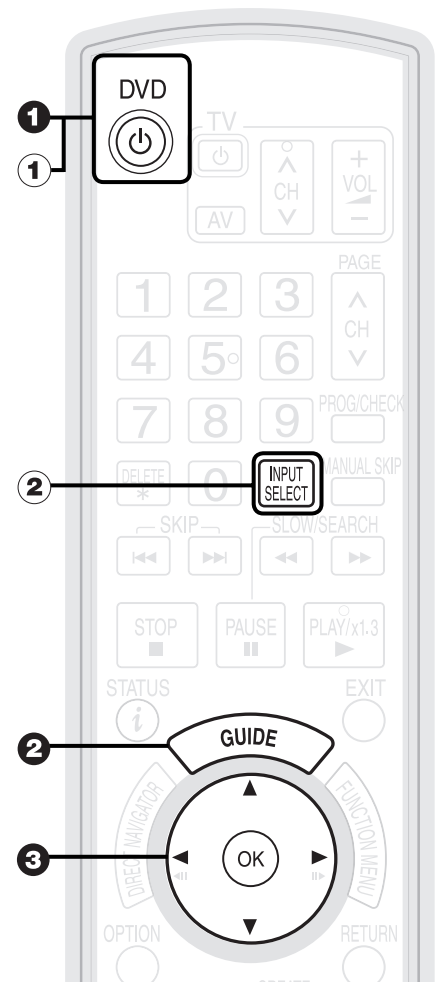

Tips

To select Digital TEXT (MHEG) and subtitles (→ 36)

To select change DVB Multi Audio (→ 47, DVB Multi Audio)

Notes

The TV Guide list is not displayed immediately after purchasing this unit.

Tips

When “Power Save” is set to “Off”, you can watch the Satellite Programme without turning the unit on (→ 56).

Playback

Refer to “Advanced Playback” (→ 32) for detail information.

Preparation:

Turn on the television and select the appropriate video input to suit the connections to this unit.

Playing Discs

RAM **-R** **-R DL** **-RW(V)** **+R** **+R DL** **+RW** **DVD-V** **-RW(VR)** **CD** **VCD**

1  to turn the unit on.

2  to open the tray (Button located on front of the unit).
– Insert a disc (→ 14).

3  – The tray closes and play begins.

Stopping Play

Press [■ STOP].

– The stopped position is memorized.

(Resume play function)

– The stopped position is cleared when you press [■ STOP] several times.

Pausing Play

Press [⏸ PAUSE].

– Press again to restart play.

Menu Screens on the TV

DVD-V **VCD**

Generally, menu screens that appear on the TV may be navigated as follows: e. g.,

DVD TOP MENU

- ▶ Play
- Chapter List
- Audio Tracks
- Subtitles
- Trailer

DVD-V

1 ▲, ▼, ◀, ▶ to select an item, then 

You can sometimes use the numbered buttons to select an item.

VCD

Press the numbered buttons to select an item.

e. g., “5”: **0** → **5** “15”: **1** → **5**

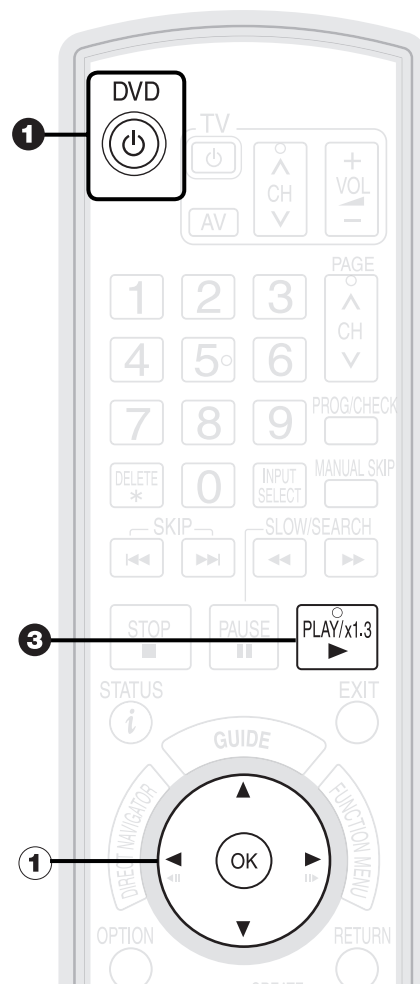

Tips

To return to the menu screen

DVD-V

1. Press [OPTION].
2. Press [▲, ▼] to select “Top Menu” or “Menu” and press [OK].

VCD

Press [RETURN].



Notes

• **RAM** **-R** **-R DL** **-RW(V)** **+R** **+R DL** **+RW** **-RW(VR)**

Playback starts from the most recent title.

• **DVD-V** **VCD**

Playback starts from the point specified by the disc.

• **CD**

Playback starts from the beginning of the disc.

• Depending on the disc type, playing may automatically start without pressing [▶ PLAY].

• The unit takes some time to read the disc before play starts.

• Discs continue to rotate while menus are displayed. Press [■ STOP] when you finish to preserve the unit’s motor and your television screen.

• If “⊙” appears on the TV, the operation is prohibited by the unit or disc.

Recording Television Programmes

Refer to “Important Notes for Recording” (→ 21) and “Advanced Recording” (→ 22 to 24) for detail information on recording.

RAM -R -R DL -RW(V) +R +R DL +RW

Preparation:

- Turn on the television and select the appropriate video input to suit the connections to this unit.
- **RAM** If the disc is protected, release protection (→ 48).

DVD

- 1  to turn the unit on.

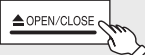
- 2  to open the tray (Button located on front of the unit).

- Insert a disc with enough remaining blank space and press [▲ OPEN/CLOSE] again to close the tray.
- When the format confirmation screen is displayed (→ 23)

PAGE

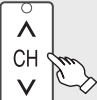
- 3  to select desired channel.



- To select with the numbered buttons (→ 16)
- When no channel setting is performed on the unit and broadcast is recorded directly from the satellite receiver, select a channel on the connected equipment and press [INPUT SELECT] to select “AV2”.

REC MODE

- 4  to select the recording mode.



Recording mode (→ 22) Remaining time

REC

- 5  to start recording.



Elapsed recording time

Pausing Recording

Press [|| PAUSE].

- Press again to restart recording. (The title is not divided.)

Stopping Recording

Press [■ STOP].

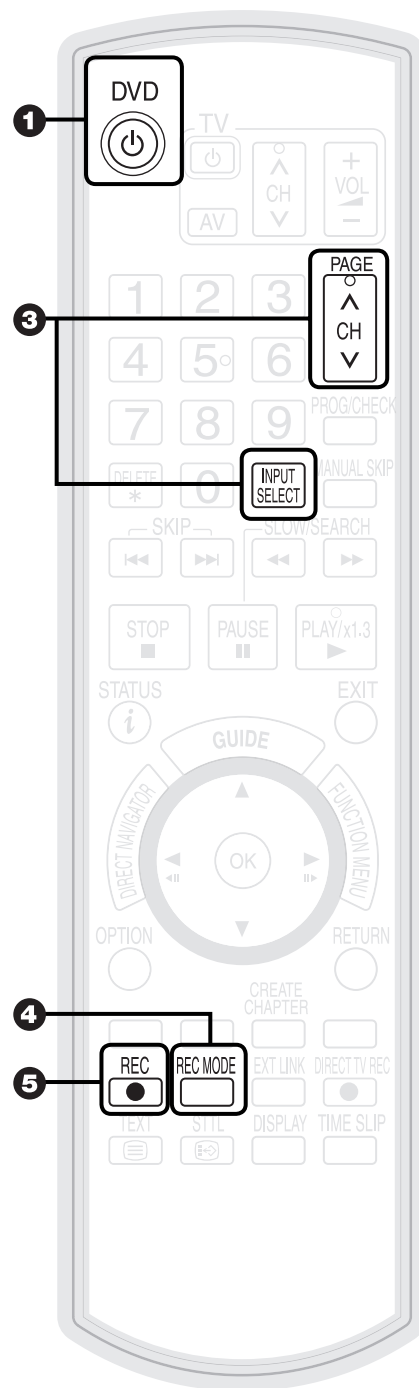

Tips

RAM -R -R(V) +R +R DL +RW

To use a new disc, formatting is necessary.

Notes

• **-R -R DL -RW(V) +R +R DL +RW**

It takes about 30 seconds for the unit to complete recording management information after recording finishes.

- You cannot change the channel or recording mode during recording.
- This unit cannot record NTSC signals to discs that already have PAL signal recordings.

Timer Recording

What is Freeview built-in?

Freeview built-in is a function that enables timer recordings to be controlled by the signal sent from the broadcaster. "Guide Link" is available.

"Guide Link" — If you set a timer recording from the TV Guide, recording start and stop times can be controlled by the broadcaster, e.g., delayed start.

This is indicated by "Guide Link" in the Timer Recording screen in step ② (→ below).

If you set a timer recording from the TV Guide, the recording's start and stop times are controlled by the signal sent from the broadcaster. If the signal is not sent correctly, the recording may lack the beginning or the ending part of the programmes.

In order to make the timer recording work successfully, we recommend you set the start time earlier and the end time later by some minutes, up to a maximum of 10 minutes for Guide Link to function.

e.g. When you set the timer recording for a programme that will start at 10:00 and end at 11:00, set "9:58" and "11:05" in step ③ (→ below).

Refer to "TV Guide" (→ 30) and "Advanced Timer Recording" (→ 27) for detail information on TV Guide.

RAM -R -R DL -RW(V) +R +R DL +RW

Preparation:

- Turn on the television and select the appropriate video input to suit the connections to this unit.
- Turn on this unit.
- Insert a disc that you use for recording (→ 14).
- **RAM** If the disc is protected, release protection (→ 48).
- Confirm that the clock on the unit's display is set to the correct time.



– The TV Guide list appears.



Time	19:30	20:00	20:30	21:00	21:30
1	BBC1	CSI NY	DIY	O.S.	Red Cap
2	BBC2	HotWars	Holiday Programme		
7	ITV1	Emmerd	Coronation Street	The Bill	
10	Channel4	Scrapheap Challenge	Pepsi Chart Show		
31	Channel5	News	Sex in the City	Terminator2	
45	ITV2	Me out of here!	Pop Idol	News	
70	S4C	Rugby	15 to 1	Scrapheap Challenge	



Name	Date	Start	Stop	Mode	STTL
3 BBC 6/3	THU	20:20	22:00	SP	OFF

All Services: BBC 2
 ← Holiday Programme (Guide Link) Programme Name
 Press OK to store the programme.

"Guide Link" is displayed here.

③ Confirm the programme (start and end time) by TV magazine, etc. and correct if necessary using



- The settings are stored and the timer programme is on.
- The timer icon is displayed.
- "D" lights on the unit's display to indicate timer recording standby has been activated.
- Repeat steps ②-③ to programme other recordings.
- Press [D/1] to turn the unit off.

20:00	20:30	21:00	21:30
		Red Cap	
		Ⓢ	holiday Programme

Timer icon

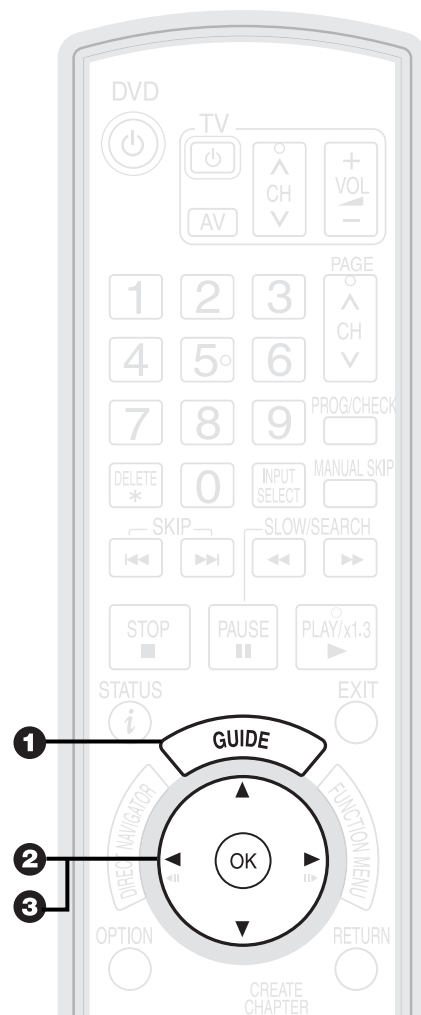

Tips

RAM -RW(V) +R +R DL +RW

To use a new disc, formatting is necessary.

To check programmes (→ 29)

To cancel a timer recording programming

1. Press [▲, ▼, ◀, ▶] to select the programme (the timer icon is displayed) and press [OK].
– Confirmation screen appears.
2. Press [◀, ▶] to select "Yes" and press [OK].
– The timer icon disappears.

Notes

- The TV Guide list is not displayed immediately after purchasing this unit.
- The TV Guide system will not work if the clock is not set correctly.
- If "NTSC" has been selected for "TV System" (→ 55), the TV Guide system cannot be used.
- "FR" recording mode is not available when the timer programme is controlled by "Guide Link".

"Guide Link" will not be displayed and will not function under the following conditions.

- Timer programmes set manually (→ 27).
- Timer programmes set from the TV Guide are modified or start/stop time changed by more than 10 minutes from original time.

Deleting Titles

Preparation:

- Turn on the television and select the appropriate video input to suit the connections to this unit.
- **RAM** If the disc is protected, release protection (→ 48).
- Press [▲ OPEN/CLOSE] and insert a disc. Press [▲ OPEN/CLOSE] again to close the tray.

Important:

Once deleted, contents cannot be recovered.

Delete Navigator

RAM -R -R DL -RW(V) +R +R DL +RW

1 With the unit stopped

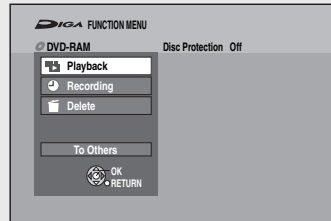

2 ▲, ▼ to select “Delete”, then OK

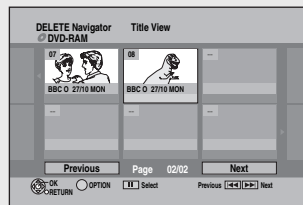
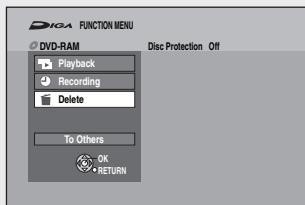

3 ▲, ▼, ◀, ▶ to select the title, then PAUSE

- A check mark is displayed. Repeat this step until you select all necessary items.
- Press [PAUSE] again to cancel.

4 OK

5 ◀ to select “Delete”, then OK



Tips

To return to the previous screen

Press [RETURN].

To view other pages

Press [▲, ▼, ◀, ▶] to select “Previous” or “Next” and press [OK].

- You can also press [◀◀, ▶▶] to view other pages.

Delete Titles During Playback

RAM -R -R DL -RW(V) +R +R DL +RW

1 During playback



2 ◀ to select “Delete”, then OK

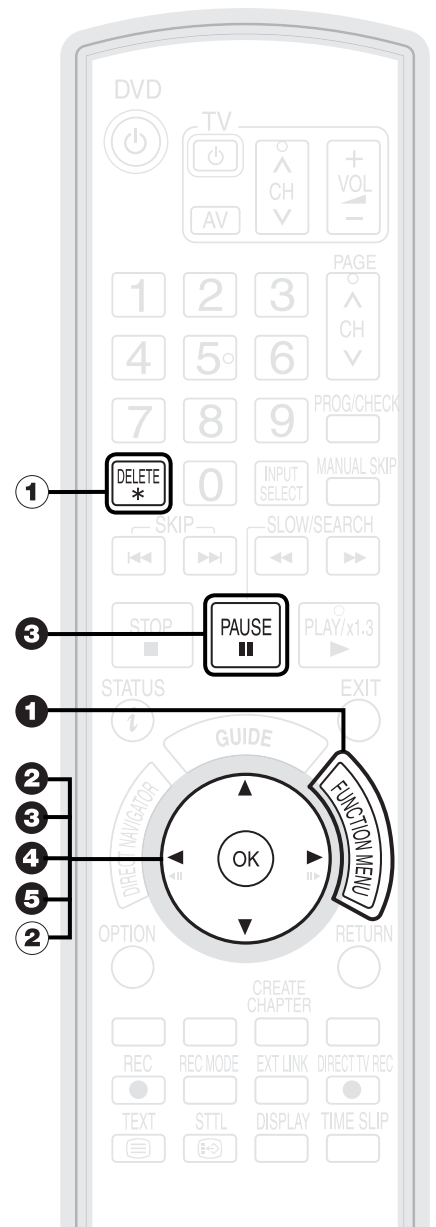

Notes

- You cannot delete while recording.
- **+R +R DL +RW** Even if you have set protection on other equipment, such titles are deleted.



Tips

- **RAM** Deleting an item increases the available disc space by the amount of space taken by the item deleted.
- **-R -R DL +R +R DL** Available disc space does not increase after deletion.
- **-RW(V) +RW** Available disc space increases when you delete the last title (If you format the disc, all of the disc space will be available. (→ 48)).

Important Notes for Recording

Selecting audio for recording

Broadcast in multi-channel sound:
 You can select audio language when received audio in multi-channel broadcast ("Multi Audio" appears at the bottom of digital channel information display).
 However, audio cannot be switched after recording.



Select the audio that you want to record in "DVB Multi Audio" in the on-screen display (→ 47).

About the aspect when recording a programme

RAM -R -R DL -RW(V)
 The original aspect used for the source programme will also be used with the recording.
 However, in the following cases, programme will be recorded in 4:3.
-R -R DL -RW(V)
 Programme recorded using "EP" or "FR (recordings 5 hours or longer)" recording modes will be recorded in 4:3 aspect.

+R +R DL +RW
 The programme will be recorded in 4:3 aspect.



Copy-once recording

• It is not possible to record digital broadcasts that allow "One time only recording" onto DVD-R, DVD-R DL, DVD-RW, +R, +R DL, +RW or 8 cm DVD-RAM discs. Use the CPRM (→ 72) compatible DVD-RAM.

RAM CPRM compatible discs only

-R -R DL -RW(V) +R +R DL +RW

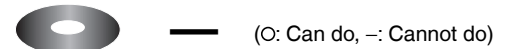

(O: Can do, -: Cannot do)

Playing the disc on other DVD players

-R -R DL -RW(V) +R +R DL
The disc must be finalised after recording (→ 49).
 It is necessary to finalise DVD-R, etc. on this unit after recording titles to them. You can then play them in the same way as a commercially sold DVD-Video. However, the discs become play-only and you can no longer record.*
 ※ You can record again if you format DVD-RW.

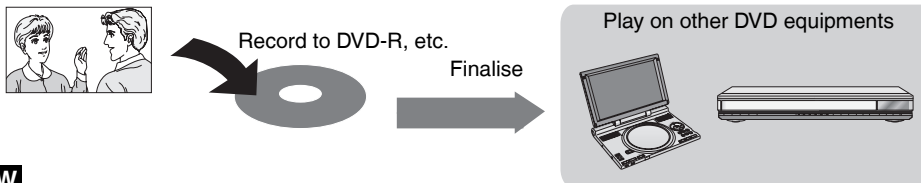

+RW
 If the disc failed to play on other equipment, we recommend you create top menu (→ 49).

Recording to DVD-R DL and +R DL

DVD-R DL and +R DL discs have two layers of recording surface on one side.
 • **It is not possible to record continuously from the first layer to the second layer.** Recording stops when space on the first layer becomes full. You must close the first layer to start recording on the second layer (→ 49). Closing makes the first layer unavailable for recording (editing is still available). You cannot cancel closing. Make certain before proceeding.

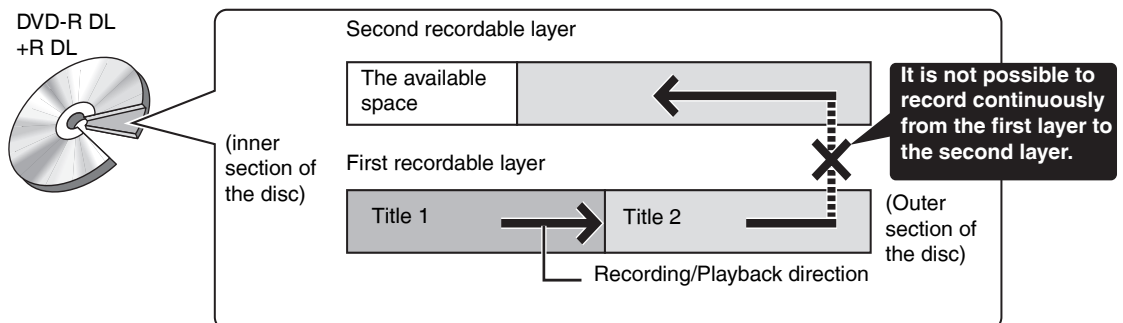

Recording Modes and Durations

Recording Mode	DVD-RAM		DVD-R, DVD-RW, +R, +RW (4.7 GB)	DVD-R DL ^{※3} , +R DL ^{※3} (8.5 GB)	
	Single-sided (4.7 GB)	Double-sided ^{※1} (9.4 GB)		First layer (L0)	Second layer (L1)
XP (High quality)	1 hour	2 hours	1 hour	55 minutes	50 minutes
SP (Standard play)	2 hours	4 hours	2 hours	1 hour 50 minutes	1 hour 40 minutes
LP (Long play)	4 hours	8 hours	4 hours	3 hours 40 minutes	3 hours 20 minutes
EP (Extra long play)	8 (6 ^{※2}) hours	16 (12 ^{※2}) hours	8 (6 ^{※2}) hours	7 hours 25 minutes (5 hours 30 minutes ^{※2})	6 hours 50 minutes (5 hours 15 minutes ^{※2})
FR (Flexible Recording)	8 hours maximum	8 hours maximum for one side	8 hours maximum	7 hours 25 minutes maximum	6 hours 50 minutes maximum

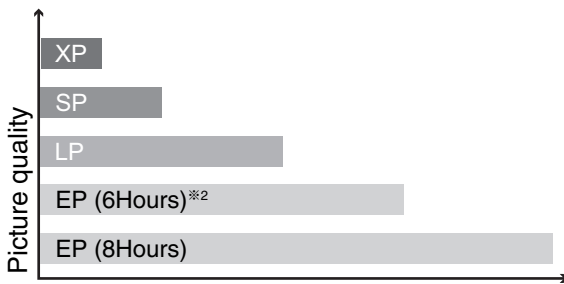

Recording time



Notes

- This unit uses variable bit rate (VBR) recording which varies the amount of data recorded to suit the picture quality, so actual recording times and remaining recording times shown by the unit will be different. (R DL +R DL) The difference will be especially noticeable.)
Use a disc enough remaining blank space.
- When recording to DVD-RAM using EP (8Hours) mode, play may not be possible on DVD players, even if they are compatible with DVD-RAM. In this case use EP (6Hours) mode.

※1 It is not possible to record or play continuously from one side of a double sided disc to the other.

※2 When "Recording time in EP mode" has been set to "EP (6Hours)" in the Setup menu (→ 52).

The sound quality is better when using "EP (6Hours)" than when using "EP (8Hours)".

※3 Refer to "Recording to DVD-R DL and +R DL" (→ 21).



Tips

- Maximum number of titles to a disc
RAM +R +R DL +RW(V) 99 titles on a disc
+R +R DL +RW 49 titles on a disc
- FR (Flexible recording mode)**
Using "Flexible Recording" is convenient in these kinds of situations:
 - When the amount of free space on the disc makes selecting an appropriate recording mode difficult
 - When you want to record a long programme with the best picture quality possible

e.g., Recording a 90 minutes programme to 4.7 GB DVD-RAM disc:

–If you select XP mode, the programme will not fit on one disc.



A second disc is necessary for 30 minutes of the programme.

–If you select SP mode, the programme will fit on one disc.

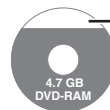

However there will be 30 minutes remaining disc space.

–If you select "Flexible Recording" the programme will fit on one disc perfectly.



You can set FR mode when programming timer recordings (→ 27) and flexible recording (→ 24).

When the format confirmation screen is displayed

Formatting is the process of making media such as DVD-RAM recordable on recording equipment.

Important:

Formatting permanently deletes all disc contents (including the contents that have been recorded on a PC), regardless of protection status of disc.

RAM -RW(V) +R +R DL +RW

The following screen may appear when inserting a new disc or a disc that has been recorded on other equipment.

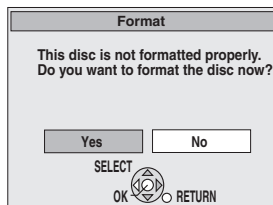

Only format the disc if you intend to use it for recording.

Do not format if you intend to view pre-recorded titles or contents from the disc.

◀ to select "Yes", then

Tips

Refer to "Formatting Discs" (→ 48) for more detail of formatting.

When removing a Recorded Disc

-R -R DL -RW(V) +R +R DL

After recording, if you press to eject the disc, the following screen may appear.

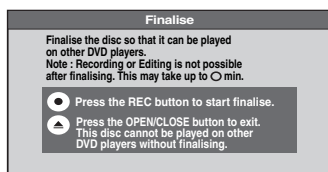

Finalising

DVD-R, etc. recorded on this unit cannot be played on other players immediately after recording. Using the Finalise feature allows you to play these discs on other players. Once the disc is finalised you will no longer be able to record onto the disc.

[However if you format the DVD-RW, you can record onto the disc again. (→ 48)]

to start finalising.

or to eject the disc without finalising.

Notes

You cannot stop finalising once you have started it.

Tips

- If you want to provide the disc with a name or set play menu select, select "Disc Name" (→ 48) or "Auto-Play Select" (→ 49) in "DVD Management" before finalising.
- Refer to "Finalising" (→ 49) for more detail of finalising.

Specifying the Recording Time

RAM -R -R DL -RW(V) +R +R DL +RW

This function allows specifying the length of recording time up to 4 hours.

During recording

On the main unit

repeatedly until the desired time is reached.

– The recording time and the unit's display change as follows:

↑	Counter (Cancel) → OFF 0:30 → OFF 1:00	↓
OFF 4:00	OFF 3:00 ← OFF 2:00 ←	OFF 1:30

Notes

- This function does not work during timer recording or Flexible Recording.
- Recording stops and the set time is cleared if you press .
- The unit turns off automatically after recording finished.

Direct TV Recording

RAM -R -R DL -RW(V) +R +R DL +RW

This function allows you to immediately start recording the programme that you are viewing on the TV without having to change the channels on this unit.

You can use the function when you connect the unit to a Q Link compatible TV using the 21-pin Scart cable.

Press and hold for about 1 second.

Tips

To stop recording
Press .

Notes

- When Digital TEXT (MHEG) (→ 36) is displayed, Direct TV recording is unavailable.
- When the unit is connected to a Panasonic TV, if you switch TV channels while using Direct TV recording, the Direct TV recording stops.
- When "EXT-L" lights on the unit's display (→ 25), Direct TV recording is unavailable.

Advanced Recording

Flexible Recording

RAM -R -R DL -RW(V) +R +R DL +RW

The unit sets the best possible picture quality that fits the programme within the remaining disc space. The recording mode becomes FR mode. Refer to “FR (Flexible recording mode)” (→ 22).

1 With the unit stopped



2 ▲, ▼ to select “To Others”, then



3 ▲, ▼ to select “Flexible Rec”, then

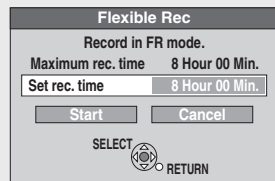

4 ◀, ▶ to select “Hour” and “Min.” and ▲, ▼ to set the recording time.

– You can set “Hour” and “Min.” using the numbered buttons.

5 When you want to start recording ▲, ▼, ◀, ▶ to select “Start”, then



– Recording starts.



Notes

You cannot record more than 8 hours.



Tips

To exit the screen
Press [EXIT].

To stop recording partway
Press [■ STOP].

To show the remaining recording time
Press [STATUS] to show the remaining recording time.



Playing while you are recording

Chasing Playback

RAM

Allows playback from the beginning of the title you are recording.

During recording



Tips

To stop play
Press [■ STOP] once.

To stop recording
2 seconds after play stops, press [■ STOP].

Simultaneous Record and Playback

RAM

Allows playback of a previous title, while recording something else.

1 During recording



2 ▲, ▼, ◀, ▶ to select the title to play, then



Tips

To stop play
Press [■ STOP].

To exit the DIRECT NAVIGATOR screen
Press [DIRECT NAVIGATOR].

To stop recording
After play stops
1. Press [DIRECT NAVIGATOR] to exit the screen.
2. Press [■ STOP].



Notes

During playing while you are recording, you cannot edit or delete titles.

Recording from a Satellite Receiver

RAM -R -R DL -RW(V) +R +R DL +RW

Manual Recording

Preparation:

- Insert a disc with enough remaining blank space (→ 14).
- **RAM** If the disc is protected, release protection (→ 48).
- Connect a satellite receiver to this unit's input terminals (→ 9).
- When the output signal from the external equipment is NTSC, change the "TV System" to "NTSC" in the Setup menu (→ 55).
This unit cannot record NTSC signals to discs that already have PAL signal recordings.

1 With the unit stopped
 to select "AV2" for the satellite receiver you have connected.

2  to select the recording mode.

3 Select the channel on the satellite receiver.

4  to start recording.

Tips

To skip unwanted parts

Press [PAUSE] to pause recording. (Press again to restart recording.)

To stop recording

Press [STOP].

Linked timer recordings with external equipment (SKY Digital STB/satellite receiver)–EXT LINK

To record programmes from a SKY Digital STB/satellite receiver using timer programming

Preparation:

- Insert a disc with enough remaining blank space (→ 14).
- **RAM** If the disc is protected, release protection (→ 48).
- Make sure you connect the AV2 input terminal of this unit to "VCR Scart Terminal" of a SKY Digital STB/satellite receiver with a 21-pin scart cable (→ 9).
- Set the "AV2 Input" and "Ext Link" to match the connected equipment in the Setup menu (→ 55).

1 Make timer programming on SKY Digital STB/satellite receiver.
– Refer to the equipment's operating instructions.

2 
– The unit turns off and "EXT-L" lights on the unit's display to indicate timer recording standby has been activated.
– While the unit is in EXT LINK standby mode or recording, most operations on this unit are prohibited ([OPEN/CLOSE], [MUTE] etc.). When you operate, press [EXT LINK] to cancel EXT LINK standby mode or recording (The unit turns on and "EXT-L" disappears.).



Tips

To cancel the external control

Press [EXT LINK] to stop recording or to cancel linked timer recording standby (The unit turns on and "EXT-L" disappears.).

Manual timer recordings (→ 27)



Notes

- In order to prevent accidental operation, press [EXT LINK] to cancel the setting after recording is finished.
- This function does not work when "TV System" is set to "NTSC" in the Setup menu (→ 55).
- This function does not work with some equipment. Refer to the equipment's operating instructions.
- The beginnings of recordings may not be recorded correctly in some cases.
- When "Ext Link" is set to "Ext Link 2", this function does not work if the input signal is NTSC system.
- Programmes are recorded as one title on this unit when the end time of the earlier timer recording and the start time of the later timer recording are close to each other.
- **RAM** To divide the titles, go to "Divide Title" (→ 42).
- While the unit is in EXT LINK standby mode or recording, AV1 output terminal outputs the signal which is input from the AV2 input terminal irrespective of "AV1 Output" setting (→ 55).

Recording from an External Device

Recording from a VCR, etc.

Connect cables while both the unit and the external device are turned off.

Front of the unit

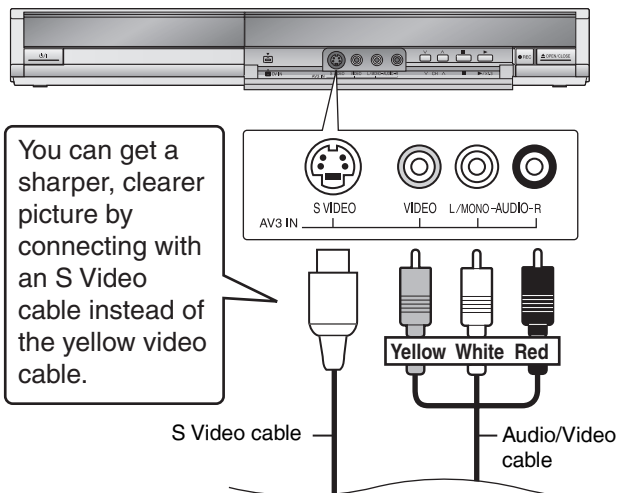

- If the audio output of the external device is monaural, connect to L/MONO on the AV3 input terminals at the front.

RAM -R -R DL -RW(V) +R +R DL +RW

Preparation:

- Turn on the unit.
- **RAM** If the disc is protected, release protection (→ 48).
- When the output signal from the external device is NTSC, change the “TV System” to “NTSC” in the Setup menu (→ 55).
This unit cannot record NTSC signals to discs that already have PAL signal recordings.
- To reduce noise in input from a video cassette recorder, set “Input NR” to “On” in the on-screen display (→ 47).

1 Insert a disc (→ 14).

2 to select the recording mode (→ 22).

3 to select the input where your external device is connected.
– Front panel inputs are AV3.

4 Start play on the external device.

5 at the point you want to start recording to the disc.

Tips

- Using Flexible Recording (→ 24), you can record the content of a video cassette (approx. 1–8 hours) to a 4.7 GB disc with the best possible quality of recording without wasting disc space.

To skip unwanted parts

Press [PAUSE] to pause recording. (Press again to restart recording.)

To stop recording

Press [STOP].
The confirmation screen appears. Press [OK].

Notes

- When timer recording starts while recording from an external device, timer recording takes priority and recording from the external device stops.
- If video is copied from another piece of equipment to this unit, then the video quality will be degraded.
- Almost all videos and DVD-Video on sale have been treated to prevent illegal copying. Any software that has been so treated cannot be recorded using this unit.

Recording from a DV Camcorder

Connect the cable while both the unit and the external device are turned off.

Front of the unit

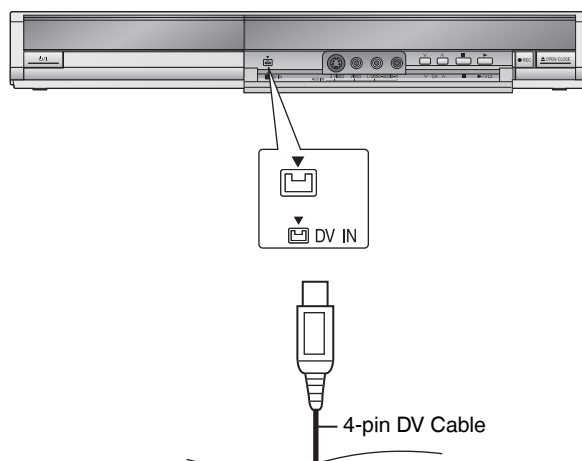

RAM -R -R DL -RW(V) +R +R DL +RW

Preparation:

- Turn on the unit.
- Insert a disc (→ 14).
- **RAM** If the disc is protected, release protection (→ 48).
- When the output signal from the external device is NTSC, change the “TV System” to “NTSC” in the Setup menu (→ 55).
- When recording bilingual programmes (→ 53, Bilingual Audio Selection).

1 to select the recording mode (→ 22).

- 2** Turn on the DV equipment and pause play at the point you want to start recording.

“DV Auto Rec” screen may appear.

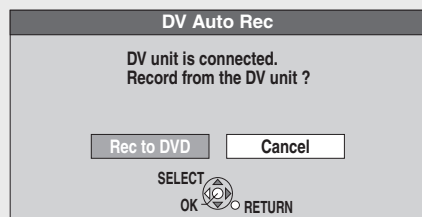

When “DV Auto Rec” screen does not appear

Perform steps 1 – 2 (→ 26, Recording from a DV Camcorder)

1. With the unit stopped
Press [FUNCTION MENU].
2. Press [▲, ▼] to select “To Others”, then press [OK].
3. Press [▲, ▼] to select “DV Auto Rec”, then press [OK].
You can proceed to step 4 (→ below).

- 3** ◀ to select “Rec to DVD”, then



- 4** ◀ to select “Rec”, then



Notes

- Only one piece of DV equipment (e.g., digital video camcorder) can be connected to the unit via the DV input terminal.
- When timer recording starts while recording from an external device, timer recording takes priority and recording from the external device stops.
- If the desired audio is not recorded, select the kind of audio for “Audio Mode for DV Input” in the Setup menu (→ 53).
- **RAM** Programmes are recorded as a single item; breaks in the images create chapters and playlists are created automatically.
- Depending on the DV equipment, the images or audio may not be input properly.
- The DV input on this unit is for use with DV equipment only. (It cannot be connected to a computer, etc.)
- If you use video camcorders from other manufacturers, these are not guaranteed to work.
- It is not possible to operate the unit from the connected DV equipment.
- The DV equipment name may not be shown correctly.
- Date and time information is not recorded, even if displayed on the camcorder.
- You cannot record and play at the same time.

Tips

When recording finishes

The confirmation screen appears.
Press [OK] to finish DV camcorder recording.

To stop recording

Press [■ STOP].
The confirmation screen appears. Press [OK].

If the DV camcorder recording function does not work properly, check the connections and DV equipment settings, and turn the unit off and back on. If that does not work, follow the instructions of “Recording from a VCR, etc.” (→ 26).

RAM -R -R DL -RW(V) +R +R DL +RW

Manual timer recordings

Preparation:

- Turn on the television and select the appropriate video input to suit the connections to this unit.
- **RAM** If the disc is protected, release protection (→ 48).
- Insert a disc with enough remaining blank space.
- Confirm that the clock on the unit’s display is set to the correct time.
- If connected via a satellite receiver, set channel there before timer recording starts.

- 1** PROG/CHECK

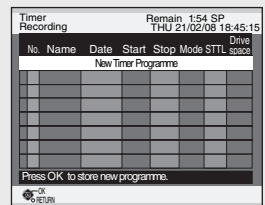

- 2** ▲, ▼ to select “New Timer Programme”, then



- 3** ◀, ▶ to move through the items and ▲, ▼ to set the items.



- Name:**
- TV Station Name/External Input
 - When recording satellite programmes, select “AV2”.
 - You can press the “Blue” button to change the category. [e.g., Free Services, Radio, Registered Profiles (→ 50, Edit Profiles)]

- Date:**
- You can set a daily or weekly programme (→ 28, Tips).

- Start (start time) / Stop (end time):**
- Hold button to change in 30-minute increments or decrements.

- Mode:**
- Recording mode (→ 22)

- STTL [Subtitles (→ 36):]**
- ON/OFF

- Programme Name:**
- Press [OK]. (→ 40, Entering Text)
- (continued on the next page)

Advanced Timer Recording

4



– The timer icon is displayed in left column.



- “⌚” lights on the unit’s display to indicate timer recording standby has been activated.
- Repeat steps 2 – 4 to programme other recordings.
- Press [⏻/⏻] to turn the unit off.



Notes

- “⌚” on the unit’s display flashes when the unit cannot go to timer recording standby. (e.g., a recordable disc is not in the disc tray).
- When timer recordings are set to start one immediately after another, the unit cannot record the beginning of the later programme.
- If two timer recording times overlap, the first recording always has priority. The second recording will start only after the first recording has finished.
- Recorded subtitles cannot be deleted later.
- Timer Recording does not start while a disc is being formatted, deleted or finalised. The recording begins afterwards.
- When “Name” is set in AV1, AV2 or AV3, STTL setting is unavailable.



Tips

To exit the timer recording list

Press [PROG/CHECK].

• “Date” Setting

Each press of [▲] changes items in the order below.

(Each press of [▼] changes items in the reverse order.)

Current date → → → → One month later
minus one day

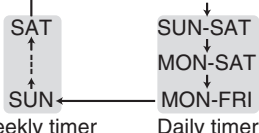

Weekly timer

Daily timer

- You can also use the numbered buttons to enter “Name”, “Date”, “Start” and “Stop”.
- You can also press [REC MODE] to switch “Mode” and press [STTL ⏻] to switch “STTL”.

To cancel a timer recording in progress

1

While the unit is on



– Confirmation screen appears.

2

◀ to select “Stop Recording”, then



Notes

Recording stops and the timer programme is deleted. (Daily and weekly timer programmes remain and timer recording will start from the next time the timer recording is set.)

To deactivate timer programme (e.g. to interrupt a daily or weekly timer programming)

1

PROG/CHECK



– See “Timer Recording screen icons” (→ 29) for explanation of icons displayed.

2

▲, ▼ to select the programme.

3



– “⌚” (→ 29) disappears from the timer recording list.
– Press the “Red” button again to activate timer programme.



Tips

You can deactivate the timer programme in the following procedure as well.

Perform steps 1 – 2 (→ above)

1. Press [OPTION].
2. Press [▲, ▼] to select “Timer Off”, then press [OK].





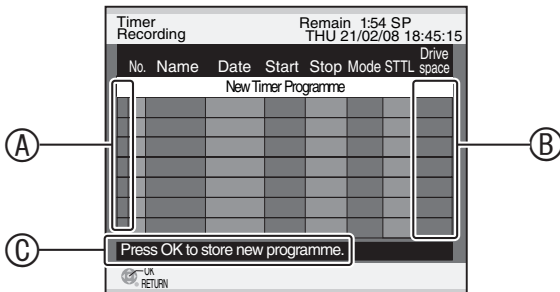

Check, Change, or Delete Programmes

The timer recording list can be viewed even when the unit is off.

- 1**  , then **▲**, **▼** to select the programme.



A Timer Recording screen icons

-  : Timer programme is active.
-  : Currently recording
-  : Programmes are overlapped. Recording of the programme with the later start time starts when the earlier programme finishes recording.
-  : You stopped a weekly or daily timer recording. The icon disappears when the next timer recording starts.
-  : The disc was full. (not enough space)
-  : The TV programme may not be recorded due to copy-protect.
-  : Recording stopped (Dirty disc, etc.)

B Drive space

- OK: Recordable
- (Date): For recordings made daily or weekly, the display will show until when recordings can be made (up to one month ahead from the present time) based on the time remaining on the disc.
- ! : It may not be possible to record because:
 - The disc is write-protected.
 - There is no more space left.
 - The number of possible recordings has reached its maximum.
 - The new timer recording will completely or partially record over this timer recording.

C Channel name, programme name and other information are displayed.

- 2a**  to delete.
– You cannot delete programmes that are currently recording.
- 2b**  to modify the programme.
▲, **▼**, **◀**, **▶** to make changes,
then 

Tips

- You can enter up to 16 programmes a month in advance.
- You can also delete a programme with the following steps**
 1. Press **▲**, **▼** to select the programme and press [OPTION].
 2. Press **▲**, **▼** to select “Delete” and press [OK].

To exit the timer recording list
Press [PROG/CHECK].

Notes

- Recording may fail if there are changes to the station's programming.
- “” disappears from the unit's display when no timer programme is set or when all timer programmes are deactivated.
- The “Guide Link” function may not work if you manually change the start/end time by over 10 minutes.
- Programmes that failed to record are deleted from the timer recording list at 4 a.m. two days later.

Notes on timer recording

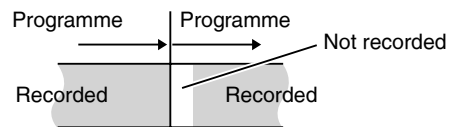

- When a timer recording is set, DVDs that were recorded using a different TV system cannot be played unless the TV system is changed in the Setup menu (→ 55) or the timer recording has completed or has been cancelled.
- Timer recordings are activated regardless of whether the unit is turned on/off.
- Timer recordings begin when the set time is reached even when playing.
- Timer recordings do not begin while editing.
- If the unit is turned on when timer recording begins, it remains turned on after recording finishes. It does not turn off automatically. You can turn the unit off during timer recording.
- If the unit is not put in the timer recording standby mode at least 10 minutes before the programmed timer recording starting time, the “” flashes on the unit's display.
- When you programme successive timer recordings to start immediately one after the other, the unit cannot record the part at the beginning of the later programmes.



Making timer recordings on the television

To make a timer recording with your television, connect to a television with a Q Link function (→ 38) that you can use for setting timer recordings using a fully wired 21-pin Scart cable (→ 8, 9).

1 Make timer programming on the TV.

- 2**   to turn the unit off.
– The start and end of recording is controlled by TV.

Tips

To stop recording
Press **[STOP]**.

Notes

- When this unit is in EXT LINK standby (“EXT-L” on the unit's display lights), recording from TV does not start.
- Programmes are recorded as one title on this unit when the end time of the earlier timer recording and the start time of the later timer recording are close to each other.

RAM To divide the titles, go to “Divide Title” (→ 42).

TV Guide

What is TV Guide?

The TV Guide gives you an overview of the digital television and radio programmes up to 7 days. For many of these programmes, you can select additional information provided by the stations. You can search the programme preview according to various topics such as sport, films etc., according to categories such as TV or radio. You can easily find the desired programmes and set Timer recording.

Landscape view

Broadcast date → Mon 18th
Broadcast time → 20:00-21:00 | Coronation Street

Timer icon (→ 19)

Selected programme

- : current programme
- : future programme

TV Guide: Landscape (Mon 18/02/08 19:35)

Time	19:30	20:00	20:30	21:00	21:30
1 BBC1	CSI NY DIYS.O.S.	Red Cap			
2 BBC2	HotWars	Holiday Programme			
7 ITV1	Emmerdale	Coronation Street	The Bill		
10 Channel4	Scrapheap Challenge	Pepsi Chart Show			
31 Channel5	News	Sex in the City	Terminator2		
45 ITV2	Me out of here!	Pop Idol	News		
70 S4C	Rugby	15 to 1	ScrapheapChallenge		

TV Guide: Portrait (Mon 18/02/08 19:35)

Time	19:30-20:00	20:00-21:00	21:00-22:00	16:00-17:45	20:10-21:40	00:15-02:30	19:30-21:00	22:00-23:50	23:50-02:00
1 BBC1	Emmerdale		The Bill	Terminator	Predator	James Bond - Goldfinger	Scream	American Pie	High Noon

Landscape view:

TV Guide offers detailed information as if you see a TV programme magazine. This is convenient to check the status of Timer recording.

Portrait view:

This is convenient to narrow down channels to search for the programme you want to watch.

To switch between Landscape view and Portrait view

Press [GUIDE].

Portrait view

Using the TV Guide

To change channels	<p>Landscape view Press [▲, ▼] to select a channel.</p> <p>Portrait view Press [◀, ▶] to select a channel.</p> <p>The TV Guide list appears for this channel.</p>
To view a programme list for another day	<ul style="list-style-type: none"> • Jump ahead 24 hours Press the "Green" button to jump ahead by one day. • Jump back 24 hours Press the "Red" button. You can only jump back to the current date. Past information cannot be viewed.
To browse through the TV Guide list	Press [∧, ∨ CH].
To see programme information (programme name, programme duration, broadcast time, description) (Programmes with the ⓘ symbol)	<p>Press [STATUS ⓘ].</p> <p>• Press [▲] and [▼] to scroll up and down.</p> <p>To show other pages Press [∧ CH] (Previous) or [∨ CH] (Next).</p> <p>To return to the TV Guide list Press [STATUS ⓘ].</p>
To return to the previous screen	Press [RETURN].
To exit the screen	Press [EXIT].



Notes

- The receipt of the TV Guide system data is only possible via the aerial input of this unit. The receipt of the TV Guide data via externally connected satellite receivers is not possible.
- The TV Guide system setup will not work if the clock is not set correctly.



Tips

When the unit displays "No Data" or the empty TV Guide list:

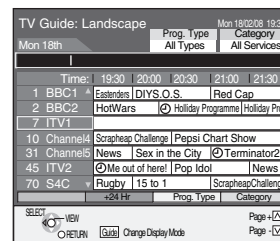



The "empty" field

- Some digital broadcast may not send programme information.
Set the timer recording manually (→ 27, Manual timer recordings).

Selecting the programme from the desired programme type or category

This function lets you display a TV Guide list sorted by programme type (e.g. Movies, Sport) or category (e.g. Free Services, Radio).

1a  to display the list of programme type.

1b  to display the list of categories.

2 ▲, ▼ to select the desired item.

Prog. Type	Category
All Types	All Services
All Types	All Services
Movies	Free Services
News and Factual	Radio
Entertainment	Information
Sport	Profile 1
Children's	Profile 2
Education	Profile 3
Lifestyle	Profile 4
Drama	

3 

- A list appears with all programmes of the selected item.
- When you select the landscape view, the programmes that belong to the selected programme type is highlighted.

TV Guide: Landscape		Mon 18/02/08 19:35
Time	Prog. Type	Category
19:00 - 20:00	Emmerdale	In today's show we will find a way...
19:30	20:00	20:30
1	BBC1	Estimote! DIV S.O.S.
2	BBC2	Hot Wars
7	ITV1	Emmerdale
10	Channel4	Scrappheap Challenge
31	Channel5	News
45	ITV2	Me out of here!
70	S4C	Rugby

e.g., Programme type, “News and Factual” is selected in step 2 of Landscape view.

4 ▲, ▼, ◀, ▶ to select the programme.



Notes

- If the unit is disconnected from the AC mains, all programme data are lost.
- The programme list is available immediately if this unit has found a digital station and loaded the information in the memory. This process can take a while depending on the particular station.
- The programme list data are continuously downloaded in the background when the unit is turned on. That means that the programme list can sometimes change while you are looking at it.



Notes

The broadcasters allocate individual programmes to topic areas. This function does not work properly unless the information which distinguishes the programme type and categories sent from broadcast stations is correct.



Tips

To return to the previous TV Guide list before you have selected the programme type or categories

Select “All Types” of the programme type and “All Services” of the categories in step 2 above.

To return to the previous screen

Press [RETURN].

To exit the screen

Press [EXIT].

Advanced Playback

Selecting Titles to Play

You can easily select and play recorded programmes by using DIRECT NAVIGATOR.

RAM -R -R DL -RW(V) +R +R DL +RW -RW(VR)

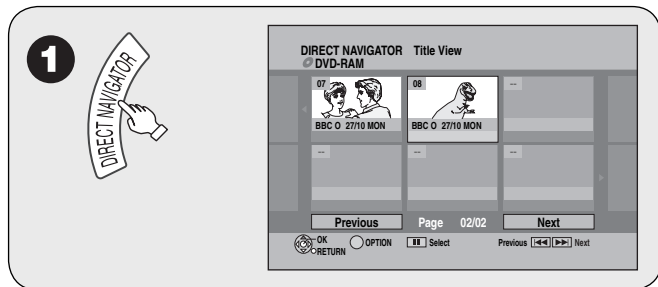

1



2

▲, ▼, ◀, ▶ to select the title you want to watch, then 



Tips

To select the title with the numbered buttons

e.g., "5": [0] → [5]
"15": [1] → [5]







To view other pages

Press [▲, ▼, ◀, ▶] to select "Previous" or "Next" and press [OK].
– You can also press [◀◀, ▶▶] to view other pages.

To exit the DIRECT NAVIGATOR screen

Press [DIRECT NAVIGATOR].

DIRECT NAVIGATOR screen icons

-  Protected.
-  Not recorded due to recording protection (Digital broadcasts, etc.)
-  It cannot be played because data is damaged, etc.
-  Currently recording.
-  "One time only recording" restriction (→ 72, CPRM)
-  (NTSC) Title recorded using a different encoding system from that of the TV system currently selected on the unit.
-  (PAL)
- Alter the "TV System" setting on this unit to suit (→ 55).

Search

During playback

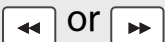

- There are 5 search speeds. Each press increases the search speed. (**+R +R DL +RW** up to 3 speeds)
- Press [▶ PLAY] to restart normal playback.



Tips

Depending on the disc, search may not be possible.

Skip

You can skip to the beginning (or the end) of Title/Chapter. Skip is operated for each chapter.

During playback or while paused

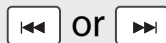

– Each press increases the number of skips.

Direct Play

During playback, you can access specific titles or scenes through direct entry of the numbered buttons.

1	2	3	e.g., "5":	[0] → [5]
			"15":	[1] → [5]
• MP3 and JPEG				
4	5	6	e.g., "5":	[0] → [0] → [0] → [5]
			"15":	[0] → [0] → [1] → [5]
7	8	9		
DELETE *	0	INPUT SELECT		

Quick View (Play x1.3)

RAM

Allows you to increase the play speed slightly without distorting the audio.

During playback

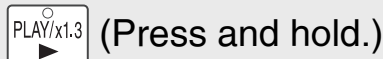

– Press again to return to normal speed.

Slow-motion Play

RAM **-R** **-R DL** **-RW(V)** **+R** **+R DL** **+RW**
DVD-V **-RW(VR)** **VCD**

While paused

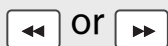

- There are 5 slow-motion speeds. Each press increases the speed.
- Press [▶ PLAY] to restart normal playback.



Notes

- If continued for approx. 5 minutes, slow-motion play pauses automatically (except **DVD-V** **VCD**).
- **VCD** allows slow-motion in the forward direction only.

Frame-by-Frame Viewing

RAM **-R** **-R DL** **-RW(V)** **+R** **+R DL** **+RW**
DVD-V **-RW(VR)** **VCD**

While paused



- Each press shows the next or previous frame.
- Press and hold to advance or reverse frame-by-frame in succession.
- Press [▶ PLAY] to restart normal playback.



Notes

VCD allows Frame-by-Frame in the forward direction only.

Time Slip

RAM
-R **-R DL** **-RW(V)** **+R** **+R DL** (This function does not work with finalised discs.)
+RW **-RW(VR)**

Use to skip in 1-minute or 10-minute increments.

1 During playback



2 ▲, ▼ to select the time, then



- Each time you press [▲, ▼], the time increases [▲] or decreases [▼] by 1-minute intervals.
- Press and hold for 10-minute intervals.

Manual Skip

RAM
-R **-R DL** **-RW(V)** **+R** **+R DL** (This function does not work with finalised discs.)
+RW **-RW(VR)**
Skips approx. 1 minute forward with each press.

During playback



Create Chapters

RAM
When creating chapters in your favourite scenes, you can easily reach the head of scene using [◀◀, ▶▶] (SKIP) or play on Chapter View (→ 43).

During playback



Tips

Chapters cannot be created during EXT LINK standby (→ 25).

Playing Still Pictures (JPEG), MP3

Playing Still Pictures (JPEG)

-R -R DL CD

You can play still pictures recorded with a computer onto a DVD-R, DVD-R DL or CD-R/CD-RW (Close the session or finalise the disc after recording).

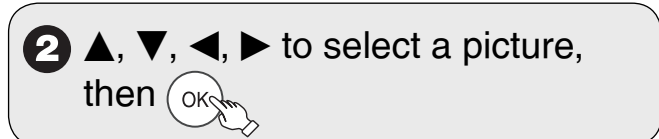
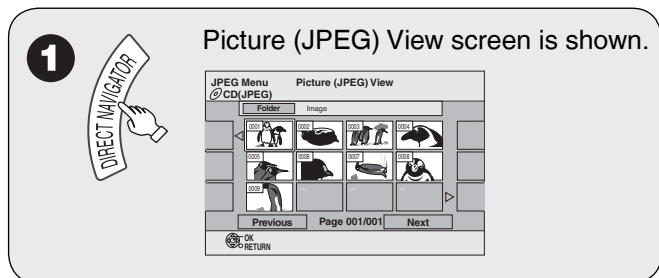

Tips

To stop viewing a picture
Press [■ STOP].

To exit the menu screens
Press [DIRECT NAVIGATOR].

To view other pages
Press [▲, ▼, ◀, ▶] to select "Previous" or "Next" and press [OK].
– You can also press [◀◀, ▶▶] to view other pages.

To select the still picture with the numbered buttons
e.g., "5": [0] → [0] → [0] → [5]
"15": [0] → [0] → [1] → [5]
"115": [0] → [1] → [1] → [5]
"1115": [1] → [1] → [1] → [5]

When you insert discs which contain both MP3 and still pictures (JPEG)

The screen shown below is displayed.

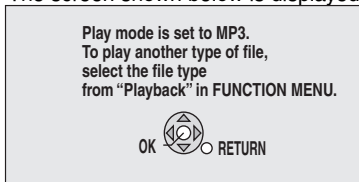

- If the playback mode on the screen is set to JPEG, press [OK].
- Otherwise:
 1. Press [RETURN] to exit the screen.
 2. Press [FUNCTION MENU].
 3. Press [▲, ▼] to select "Playback", then press [OK].
 4. Press [▲, ▼] to select "JPEG", then press [OK].

Selecting Still Pictures in Another Folder

1 From the Picture (JPEG) View screen
▲, ▼, ◀, ▶ to select "Folder",
then 

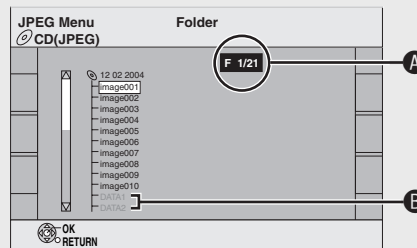

- A**: Selected Folder No./Total Folder No.
If the folder has no compatible file, "--" is displayed as the folder number.
- B**: You cannot select folders that contain no compatible files.

2 ▲, ▼ to select the desired folder, then 

Tips

To return to the previous screen
Press [RETURN].

Slide Show

You can display still pictures one by one with regular interval.

1 From the Picture (JPEG) View screen
▲, ▼, ◀, ▶ to select "Folder",
then 

2 ▲, ▼ to select "Start Slide Show", then 

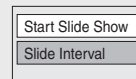

Tips

To stop the Slide Show
Press [■ STOP].

To change the rate at which pictures are displayed

1. In step **2** above, press [▲, ▼] to select "Slide Interval", then press [OK].
2. Press [◀, ▶] to select desired interval (0 to 30 seconds), then press [OK].

Rotate Pictures

1 While playing a picture



2 ▲, ▼ to select “Rotate RIGHT” or “Rotate LEFT”, then OK

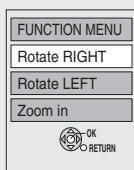

Notes

To return to the picture to its original position

Press [▲, ▼] to select the opposite rotation in step 2 and press [OK].

- Rotation information will not be stored.

Zoom

1 While playing a picture



2 To zoom in:
▲, ▼ to select “Zoom in”, then OK

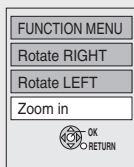

Notes

To return to the picture to its original size

Press [▲, ▼] to select “Zoom out” in step 2 and press [OK].

- When zooming in, the still picture may be cut off.
- “Zoom in” information is not stored.
- “Zoom in” and “Zoom out” do not work with images that have a resolution larger than 640 x 480 pixels.

Picture Properties

Picture information is shown (e.g., shooting date).

While playing a picture

STATUS



twice to display picture properties.

Shooting Date

12:03:00 7/5	
Date	26/11/2004
No.	2/ 30

STATUS



again to exit.



Notes

Depending on the camera or editing software, shooting dates may not be displayed correctly.

Playing MP3s

-R -R DL CD

You can play MP3 files recorded with a computer onto a DVD-R, DVD-R DL or CD-R/CD-RW (Close the session or finalise the disc after recording).

1



Selected group

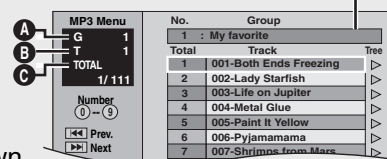

– Track list is shown.

- A**: Group No.
- B**: Track No. in the group
- C**: Track No./Total tracks in all groups

2

▲, ▼ to select a track, then OK to play.



Tips

- “” indicates the track currently playing.

To stop playing

Press [STOP].

To exit the menu screens

Press [DIRECT NAVIGATOR].

To view other pages

Press [◀, ▶].

To select the track with the numbered buttons

e.g., “5”: [0] → [0] → [0] → [5]

“15”: [0] → [0] → [1] → [5]

Using the Tree Screen to Find a Group

1

From the track list

▶ while a track is highlighted to display the tree screen.

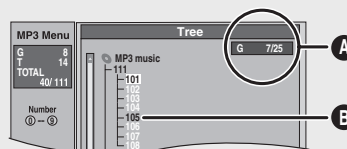

- A**: Selected Group No. /Total Group No. If the group has no compatible track, “-” is displayed as the group number.
- B**: You cannot select a group that contains no compatible track.

2

▲, ▼ to select a group, then OK

– The track list for the selected group appears.



Tips

To return to the track list

Press [RETURN].

- When you insert discs which contain both MP3 and still pictures (JPEG), files selection screen appears (→ 34, left column, Tips). Press [OK].

Information Messages

Digital Channel Information

You can display the information about programmes (programme name, broadcast time, etc.).

With the unit stopped

STATUS



to show the screen information.

When the digital channel information is being displayed,

– press [STATUS] again and detailed information will be displayed (only when “info ” is displayed).

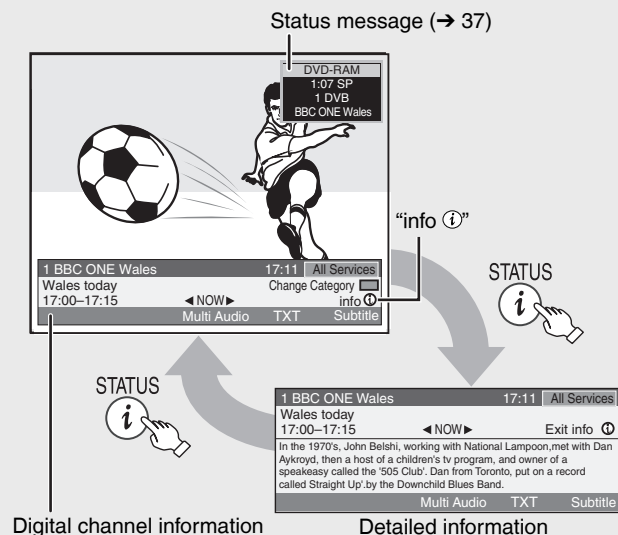

Programme name and Broadcast time

Signal Quality (→ 37)

Channel and Station Name

Category



Encrypted	During scrambled broadcasting (You cannot watch the broadcast).
Multi Audio	Programme is broadcast in multi-channel sound (→ 47, DVB Multi Audio).
TXT	Digital TEXT is possible.
Subtitle	Subtitle can be displayed.



Tips

To switch information of the current programme and the next programme

Press [◀, ▶].

- NOW: current programme
- NEXT: next programme

To select the information of another channel

Press [▲, ▼].

- Press [OK] to watch the selected channel.

To change the length of time digital channel information is displayed for

(→ 54, On-Screen Messages)



Notes

- Everytime you change the channel, a digital channel information appears automatically. They disappear again after a short time.
- If you record a digital radio broadcast or a digital broadcast that is not being received correctly, digital channel information is also recorded and will remain visible during playback.

Showing the Digital TEXT (MHEG)

When “TXT” appears in digital channel information



to show the Digital TEXT.

– Press again to hide.



Notes

- During recording the Digital TEXT function is not possible.
- The Digital TEXT function depends on respective stations.
- When subtitle is on or the digital channel information is displayed, the Digital TEXT function does not work.



Tips

To view another page of Digital TEXT (MHEG)

Press [▲, ▼] to select another page and press [OK].

- You can also use the numbered buttons to select another page.

Quickly access to certain topic areas and navigation

Use colour buttons according to on-screen instructions.

Showing Subtitles

When “Subtitle” appears in digital channel information



to show subtitles.

– Press again to hide.



Notes

- Programmes are recorded with subtitles when you record them with the subtitles on.
- You cannot switch subtitles during timer recording.



Tips

To select subtitle language (→ 54, DVB Preferred Subtitles)

Changing the Category

You can select one of your favourite channels by changing the category (such as Free Services, Radio and Registered Profiles (→ 50)).

When digital channel information is displayed



to change the category.

– Press [▲, ▼] to select the channel.

Signal Quality

No Signal	The digital broadcast signal is not being received.
Bad Signal	Due to poor signal conditions, etc., the digital broadcast signal has been interrupted.
No Service	No broadcasts are currently available.

If “No Signal” or “Bad Signal” is displayed, check the following:

- Check that the aerial is correctly positioned.
- Check that the current digital broadcast channel is correctly broadcasting.

Status Messages

The following messages and displays appear to let you know what operations are being performed and the status of the unit.

During playback and/or recording

STATUS



Keep pressing to cycle through available displays.

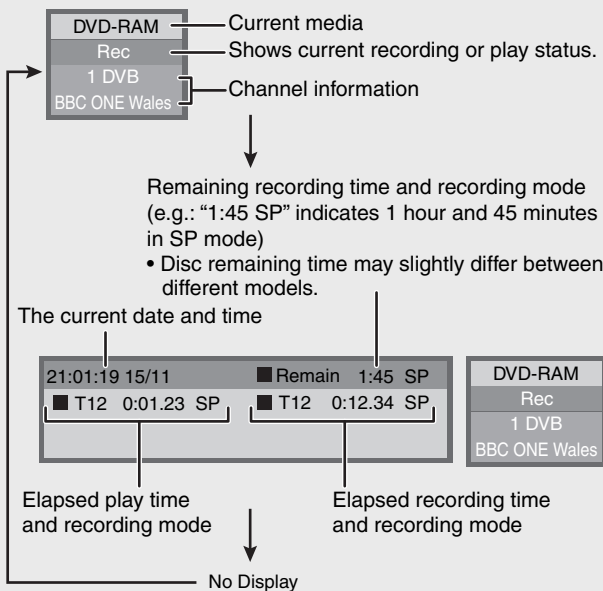

New Service Message

When a new DVB channel is added this unit will be informed automatically. Then the confirmation message appears. If you select “Yes” on the display, Auto-Setup starts (All channel settings and all created profiles are deleted. The timer recording programmes are also cancelled.).

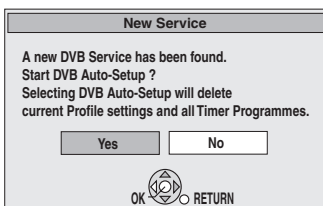

Tips

The display/hide setting can be changed (→ 54).

By using the FUNCTION MENU window you may access the main functions quickly and easily.

1 With the unit stopped

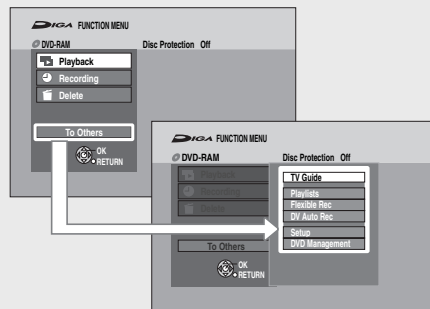

2 ▲, ▼ to select a menu item, then



– If you select “To Others”, press [▲, ▼] to select a menu item and press [OK].

Playback ▶ 32

You can select and play recorded programmes, change the Play Mode (**JPEG**, **MP3**) etc.

Recording ▶ 27

You can make timer recording settings.

Delete ▶ 20

You can delete recorded titles using Delete Navigator.

TV Guide ▶ 16, 19

You can easily find programmes you want to watch and set them for timer recording.

Playlists ▶ 44

You can create playlists by grouping your favourite chapters.

Flexible Rec ▶ 24

The unit sets the best possible picture quality that fits the recording within the remaining disc space.

DV Auto Rec ▶ 27

DV automatic recording function

Setup ▶ 50

You can change the unit’s settings using Setup menu.

DVD Management ▶ 48

You can manage discs through formatting, finalising and other operations.

Linked Operations with the TV (VIERA Link “HDAVI Control™”/Q Link)

You can enjoy linked operations with the TV and receiver by using VIERA Link or Q Link.

What is VIERA Link “HDAVI Control” ?

VIERA Link

VIERA Link “HDAVI Control” is a convenient function that offers linked operations of this unit, and a Panasonic TV (VIERA) or receiver under “HDAVI Control”. You can use this function by connecting the equipment with the HDMI cable. See the operating instructions for connected equipment for operational details.

- VIERA Link “HDAVI Control”, based on the control functions provided by HDMI which is an industry standard known as HDMI CEC (Consumer Electronics Control), is a unique function that we have developed and added. As such, its operation with other manufacturers’ equipment that supports HDMI CEC cannot be guaranteed.
- **This unit supports “HDAVI Control 3” function.** “HDAVI Control 3” is the newest standard (current as of December, 2007) for Panasonic’s HDAVI Control compatible equipment. This standard is compatible with Panasonic’s conventional HDAVI equipment.
- Please refer to individual manuals for other manufacturers’ equipment supporting VIERA Link function.

What is Q Link?

Q Link

Q Link is a convenient function that offers linked operations of this unit and a Panasonic TV. You can use this function by connecting the equipment with a fully wired 21-pin Scart cable.

Preparation:

Connect this unit to your TV with a fully wired 21-pin Scart cable (→ 8, 9).



Notes

The following systems from other manufacturers have similar function to Q Link from Panasonic.

For details, refer to your television’s operating instructions or consult your dealer.

- Q Link (registered trademark of Panasonic)
- DATA LOGIC (registered trademark of Metz)
- Easy Link (registered trademark of Philips)
- Megalogic (registered trademark of Grundig)
- SMARTLINK (registered trademark of Sony)

Preparation:

1. Connect this unit to your TV using an HDMI cable and a fully wired 21-pin Scart cable (→ 10), or to your receiver using an HDMI cable (→ 60).
2. Set “VIERA Link” to “On” (→ 55). (The default setting is “On”.)
3. Set the “HDAVI Control” operations on the connected equipment (e.g., TV).
 - **When using HDMI2 terminal of VIERA as “HDAVI Control”, set the input channel to HDMI2 on VIERA.**
4. Turn on all “HDAVI Control” compatible equipment and select this unit’s input channel on the connected TV so that the “HDAVI Control” function works properly.
Also when the connection or settings are changed, repeat this procedure.

(When the TV is on) Easy playback

VIERA Link
Q Link

When the TV is on and the following operations are performed, the TV’s input will automatically switch to HDMI input mode (VIERA Link) or AV input mode (Q Link) and the TV displays the corresponding action.

(Picture or sound may not be available for the first few seconds.)

Press [FUNCTION MENU]^{※1}, [▶ PLAY]^{※2}, [DIRECT NAVIGATOR], [GUIDE], [PROG/CHECK] etc.

(When the TV is off) Power on link

VIERA Link
Q Link

When the TV is off and the following operations are performed, the TV will automatically turn on and display the corresponding action.

(Picture or sound may not be available for the first few seconds.)

Press [FUNCTION MENU]^{※1}, [▶ PLAY]^{※2}, [DIRECT NAVIGATOR], [GUIDE], [PROG/CHECK] etc.

Power off link

VIERA Link
Q Link

When you turn the TV off, the unit is also automatically turned off. The unit is automatically turned off even if the FUNCTION MENU screen, the status message or the on-screen display is displayed, during playback or when the unit is set to a timer recording.

Even if the TV is turned off, the unit will not be turned off at the same time when recording, finalising, etc.

- When this unit is connected to an “HDAVI Control” compatible Panasonic receiver with an HDMI cable, the receiver will also turn off.

Direct TV Recording

VIERA Link^{※3}
Q Link

This function allows you to immediately start recording the programme that you are viewing on the TV (→ 23).

To stop recording

Press [■ STOP].

※1 This button is available only when this unit is on.

※2 When this button is pressed, the playback image is not immediately displayed on the screen and it may not be possible to watch the contents from where playback started.

In this case, press [◀◀] or [◀◀] to go back to where playback started.

※3 This function is available with the TV which has “HDAVI Control 3” function.

Easy control only with VIERA remote control

If you connect this unit to the TV that has "HDAVI Control 2" or "HDAVI Control 3" function with an HDMI cable, you can enjoy using more convenient functions.

You can operate this unit using the following buttons on the TV remote control.

[▲], [▼], [◀], [▶], [OK], [RETURN], [EXIT], [OPTION], and the coloured buttons.

Use the remote control for this unit to operate any other buttons (numbered buttons, etc.) that are not listed above.

- The operation of this unit may be interrupted when you press buttons on the TV remote control other than those listed above.
- The TV displays the TV tuner's picture when the linked operation is finished.
- Refer to TV operating instructions for operating the TV.

Using the FUNCTION MENU window to operate this unit

VIERA Link

1 Display this unit's "FUNCTION MENU" window using the TV remote control.

- If this unit is turned off, this unit will be turned on automatically.

2 Select the item you want to operate with the TV remote control, then 

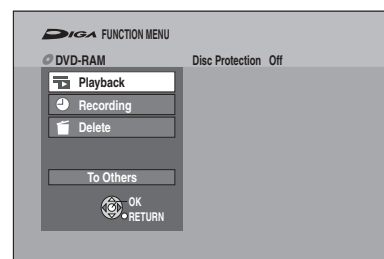

FUNCTION MENU window (→ 37)

Using the OPTION menu window to operate this unit

VIERA Link

By using the TV remote control, you can play discs using the "Control Panel" (→ below) and display the Top Menu for DVD-Video.

1 
e.g.,

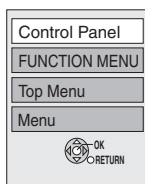

Notes

You cannot use the OPTION menu while the Top Menu for DVD-Video is displayed.

2 Select an item, then 

Control Panel	"Control Panel" is displayed (→ below).
FUNCTION MENU	FUNCTION MENU window is displayed (→ above).
Top Menu DVD-V	Top Menu is displayed (→ 17).
Menu DVD-V	Menu is displayed (→ 17).
Rotate RIGHT (JPEG)	Rotate still pictures (→ 35).
Rotate LEFT (JPEG)	
Zoom in (JPEG)	Enlarge or shrink the still picture (→ 35).
Zoom out (JPEG)	

Using the Control Panel

VIERA Link

Using the "Control Panel", you can operate search backward, search forward, stop, etc. with the TV remote control.

Perform steps **1** and **2** of "Using the OPTION menu window to operate this unit" (→ above).

The Control Panel is displayed (→ right)

- While playing a title or DVD-Video, etc.
 - [▲]: Pause, [▼]: Stop, [◀]: Search backward, [▶]: Search forward, [OK]: Play, [EXIT]: Exit the screen.
- While playing still pictures
 - [▼]: Stop, [◀]: View previous picture, [▶]: View next picture, [EXIT]: Exit the screen.

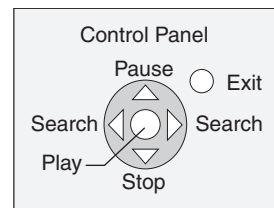

Notes

- These functions may not work normally depending on the equipment condition.
- About "HDAVI Control" function, read the manual of the connected equipment (e.g., TV) too.

When you want to leave the TV on and set only this unit to standby mode

Press [DVD] on this unit's remote control and set to standby mode.

When not using "HDAVI Control"

Set "VIERA Link" in the Setup menu to "Off" (→ 55).

Entering Text

You can give names to recorded titles, etc.

1 When viewing the Enter Name screen.

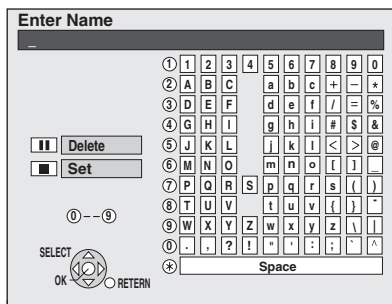

2 Press [▲, ▼, ◀, ▶] to select a character, then press [OK].

– Repeat this step to enter other characters.

3 Press [■ STOP] when you've finished entering text.



Tips

Using the numbered buttons to enter characters

e.g.: entering the letter "R"

1. Press [7] to move to the 7th row.
2. Press [7] twice to highlight "R".
3. Press [OK].

To enter a space

Press [* DELETE], then press [OK].

To delete a character

Press [■ PAUSE] on a character in the name field.

To cancel in the middle

Press [RETURN].

Characters will not be saved.



Notes

If you enter a long name, only part of it is shown in the Top Menu after finalisation (→ 49). When entering a title name, the name that will appear in the Top Menu can be previewed in "Top Menu Preview" window.



Titles-Editing

RAM

-R -R DL -RW(V) +R +R DL (You can not edit finalised discs.)

+RW -RW(VR)

You can edit titles on the DIRECT NAVIGATOR screen: deleting unwanted parts of titles such as commercials, changing Thumbnail, dividing and deleting titles, etc.



Tips

Maximum numbers of items on a disc

	RAM	-R	-R DL	-RW(V)	+R	+R DL	+RW
Titles			99				49

Accessing the Title View

Preparation:

- **RAM** Release protection (disc, cartridge → 48, Setting Protection).
- Insert a disc.

1 Press [DIRECT NAVIGATOR].

2 Press [▲, ▼, ◀, ▶] to select a title.

– Multiple editing (→ below, Tips)

3 Press [OPTION] to display the menu list.

- To view more options
 - Press [▲, ▼] to select "Edit", then press [OK].
- Items that cannot be selected are grey.

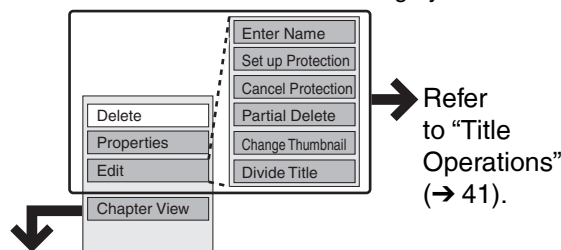

If you select "Chapter View" (→ 43)



Notes

- You cannot edit during recording.
- **+R +R DL** Management information is recorded in unused sections when you edit discs. The available space on these discs decreases each time you edit their contents.



Tips

To exit the menu screens

Press [DIRECT NAVIGATOR].

To view other pages

Press [▲, ▼, ◀, ▶] to select "Previous" or "Next" and press [OK].

– You can also press [◀◀, ▶▶] to view other pages.

Multiple editing

(Only Delete, Set up Protection/Cancel Protection)

Select with [▲, ▼, ◀, ▶] and press [■ PAUSE]. (Repeat.)

– A check mark appears. Press [■ PAUSE] again to cancel.

Title Operations

Delete

RAM -R -R DL -RW(V) +R +R DL +RW

Use to delete unneeded titles.

Important: Once deleted, contents cannot be recovered.

Perform steps ① – ③ of “Accessing the Title View” (→ 40).

- ④ Press [▲, ▼] to select “Delete”, then press [OK].
- ⑤ Press [◀] to select “Delete”, then press [OK] to confirm.



Notes

- **RAM** Deleting an item increases the available disc space by the amount of space taken by the item deleted.
- **-R -R DL +R +R DL** Available disc space does not increase after deletion.
- **-RW(V) +RW** Available disc space increases when you delete the last title (the recording space may increase slightly when other titles are deleted).
- Available disc space may not increase after erasing a short title.

Properties

RAM -R -R DL -RW(V) +R +R DL +RW -RW(VR)

Title information is shown (e.g., date, time).

Perform steps ① – ③ of “Accessing the Title View” (→ 40).

- ④ Press [▲, ▼] to select “Properties”, then press [OK].

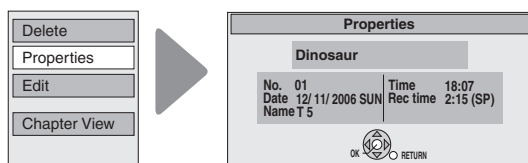

Enter Name

RAM -R -R DL -RW(V) +R +R DL +RW

You can give a name for the title.

Perform steps ① – ③ of “Accessing the Title View” (→ 40).

- ④ Press [▲, ▼] to select “Enter Name”, then press [OK].
Entering Text (→ 40).

Set up Protection/Cancel Protection

RAM +R +R DL +RW

Use to prevent accidental erasure of titles.

Perform steps ① – ③ of “Accessing the Title View” (→ 40).

- ④ Press [▲, ▼] to select “Set up Protection” or “Cancel Protection”, then press [OK].
- ⑤ Press [◀] to select “Yes”, then press [OK].

The lock symbol appears when the title is protected.

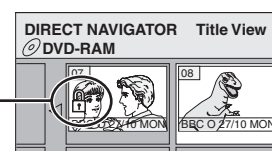

Partial Delete

RAM

Use to remove unwanted parts of titles, such as commercials.

Important: Once deleted, the parts cannot be recovered.

Perform steps ① – ③ of “Accessing the Title View” (→ 40).

- ④ Press [▲, ▼] to select “Partial Delete”, then press [OK].

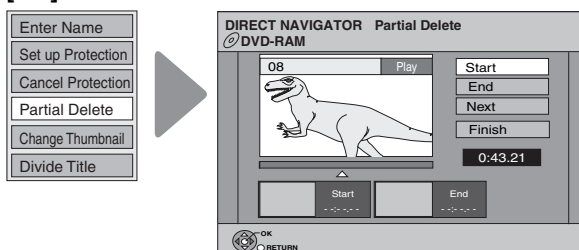

- ⑤ Press [OK] to set the “Start” point and then press [OK] again to set the “End” point of the section you want to erase.
 - For quicker editing (→ 42, Tips)
 - To delete multiple sections:
Press [▲, ▼] to select “Next”, and repeat this step.
- ⑥ Press [▲, ▼] to select “Finish”, then press [OK].
- ⑦ Press [◀] to select “Delete”, then press [OK] to confirm.



Notes

- You may not be able to specify start and end points within 3 seconds of each other.
- Available disc space may not increase after erasing short parts of titles.

Titles-Editing

Change Thumbnail

RAM -R -R DL -RW(V) +R +R DL +RW

Changes the thumbnail picture shown in the Title View screen.

Perform steps ① – ③ of “Accessing the Title View” (→ 40).

- ④ Press [▲, ▼] to select “Change Thumbnail”, then press [OK].

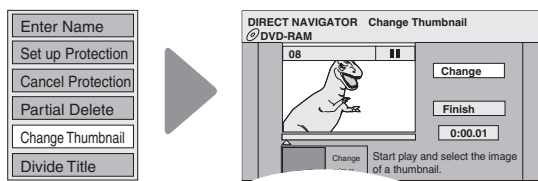

- ⑤ Press [▶ PLAY] to start play.
- ⑥ Press [OK] at the point you want to use as the thumbnail.
- For quicker editing (→ below, Tips)
 - To change the thumbnail:
Restart play and press [▲, ▼] to select “Change”, then press [OK] at the point you want to use as the thumbnail.
- ⑦ Press [▲, ▼] to select “Finish”, then press [OK].

Divide Title

RAM

You can divide a title into two.

Once divided, titles cannot be recombined.

Perform steps ① – ③ of “Accessing the Title View” (→ 40).

- ④ Press [▲, ▼] to select “Divide Title”, then press [OK].

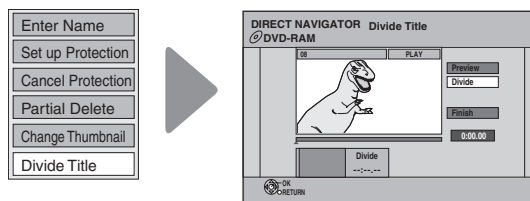

- ⑤ Press [OK] at the point you want to divide.
- For quicker editing (→ below, Tips)
 - Selecting “Preview”, then pressing [OK] plays the title from 10 seconds prior, to 10 seconds after the division point.
 - To change the point to divide at:
Press [▲, ▼] to select “Divide”, then press [▶ PLAY] to bring to the point where you want to divide, then press [OK].
- ⑥ Press [▲, ▼] to select “Finish”, then press [OK].
- ⑦ Press [◀] to select “Divide”, then press [OK].
- The title is divided at that point.



Notes

- Divided titles retain the name of the original.
- A short amount of video and audio just before and after the division point get cut out.
- You cannot divide a title when the resulting parts are too short or when the total number of titles exceeds 99.



Tips

For quicker editing

- Use search (→ 32) or Time Slip (→ 33) to find the desired point.
- To skip to the start or end of a title, press [◀◀] (start) or [▶▶] (end).
- For better precision, use slow-motion (→ 33) and frame-by-frame (→ 33).

Chapters-Creating, Editing

RAM

When creating chapters in your favourite scenes, you can easily reach the head of scene using [**◀◀**, **▶▶**] (SKIP) or play on Chapter View.



Tips

• Title/Chapter

Normally, programmes are recorded as a single item consisting of one chapter.

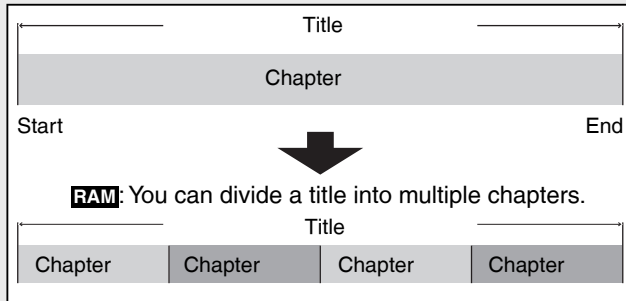

- **RAM:** You can change the order of chapters and create a playlist (→ 44).
- After finalising, titles are divided into chapters of the following lengths.

-R -R DL -RW(V) : Chapters are approx. 5 minutes long.

+R +R DL : Chapters are approx. 8 minutes long.

• Maximum numbers of items on a disc

	RAM -R -R DL -RW(V)	+R +R DL +RW
Chapters	Approx. 1000	Approx. 254

Accessing the Chapter View

Preparation:

- **RAM** Release protection (disc, cartridge → 48, Setting Protection).
- Insert a disc.

Allows viewing and editing chapters individually.

- 1 Press [**DIRECT NAVIGATOR**].
- 2 Press [**▲**, **▼**, **◀**, **▶**] to select a title.
- 3 Press [**OPTION**] to display the menu list.

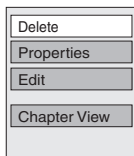

- 4 Press [**▲**, **▼**] to select “Chapter View”, then press [**OK**].
- 5 Press [**▲**, **▼**, **◀**, **▶**] to select a chapter.
 - Multiple editing (→ right, Tips)

- 6a **To play**
Press [**OK**].

- 6b **To edit**
Press [**OPTION**] to display the menu list.

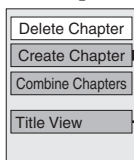

→ Refer to “Chapter Operations” (→ right).

— You can go back to the Title View.



Tips

To exit the menu screens

Press [**DIRECT NAVIGATOR**].

To view other pages

Press [**▲**, **▼**, **◀**, **▶**] to select “Previous” or “Next” and press [**OK**].

– You can also press [**◀◀**, **▶▶**] to view other pages.

Multiple editing

(Only Delete Chapter)

Select with [**▲**, **▼**, **◀**, **▶**] and press [**|| PAUSE**]. (Repeat.)

– A check mark appears. Press [**|| PAUSE**] again to cancel.

Chapter Operations

Create Chapter

You can divide a title into multiple chapters. Perform steps 1 – 6b of “Accessing the Chapter View” (→ left).

- 7 Press [**▲**, **▼**] to select “Create Chapter”, then press [**OK**].

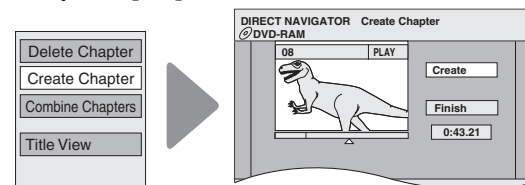

- 8 Press [**OK**] at the point you want to divide.
 - For quicker editing (→ 42, Tips)
 - Repeat this step to create additional chapters.

- 9 Press [**▲**, **▼**] to select “Finish”, then press [**OK**].



Notes

A short portion of the title just after the creation point may be lost.

Delete Chapter

You can delete the chapters for each title.

Important: Once deleted, recorded contents cannot be recovered.

Perform steps 1 – 6b of “Accessing the Chapter View” (→ left).

- 7 Press [**▲**, **▼**] to select “Delete Chapter”, then press [**OK**].

- 8 Press [**◀**] to select “Delete”, then press [**OK**].

Combine Chapters

You can combine the divided chapters.

Perform steps 1 – 6b of “Accessing the Chapter View” (→ left).

- 7 Press [**▲**, **▼**] to select “Combine Chapters”, then press [**OK**].

- 8 Press [**◀**] to select “Combine”, then press [**OK**].
 - The selected chapter gets combined with the next chapter.

Creating, Editing and Playing Playlists

RAM

-RW(VR) (play only)

You can create playlists by grouping your favourite scenes (chapters) from the recorded titles and edit the created playlists.



Tips

RAM

A playlist is a compilation of your favourite chapters as shown in the chart below.

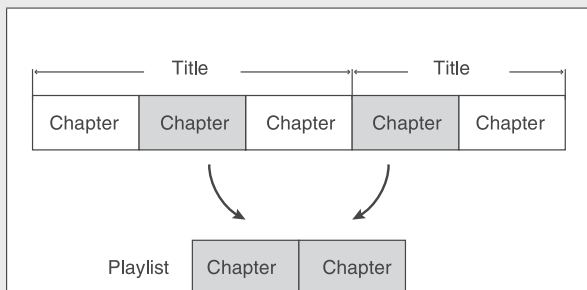

- Editing playlists doesn't modify titles.
- Playlists are not recorded separately so this doesn't use much capacity.

Accessing the Playlist View

Preparation:

- **RAM** Release protection (disc, cartridge → 48, Setting Protection).
- Insert a disc.

With the unit stopped

- 1 Press [FUNCTION MENU].
- 2 Press [▲, ▼] to select "To Others", then press [OK].

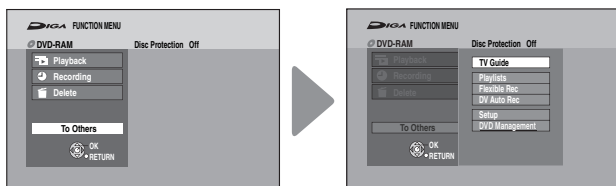

- 3 Press [▲, ▼] to select "Playlists", then press [OK].
- 4a To play
Press [▲, ▼, ◀, ▶] to select the playlist to play, then press [OK].
- 4b To create
Press [▲, ▼, ◀, ▶] to select "Create", then press [OK]. (→ right, Creating Playlists)
- 4c To edit
Press [▲, ▼, ◀, ▶] to select the playlist, then press [OPTION].
– Multiple editing (→ 45, left column, Tips)

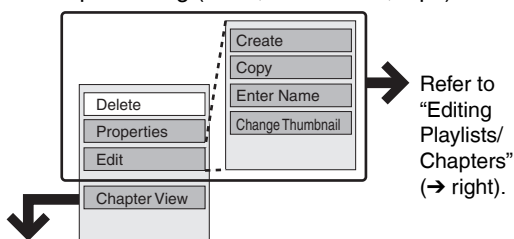

If you select "Chapter View" (→ 45)

Creating Playlists

RAM

Perform steps 1 – 4b of "Accessing the Playlist View" (→ left).

- 5 Press [◀, ▶] to select the source title, then press [▼].
– Press [OK] to select all the chapters in the title, then skip to step 7.
- 6 Press [◀, ▶] to select the source chapter you want to add to the playlist, then press [OK].
– Press [▲] to cancel.
– Press [OPTION] to select "Create Chapter", then press [OK] if you want to create a new chapter in the source title (→ 43).
- 7 Press [◀, ▶] to select the position to insert the chapter, then press [OK].
– Press [▲] repeatedly to return to step 5, if you want to add additional source titles.

Chapters are registered to the playlist. Repeat steps 6 and 7 to add other chapters.

- 8 Press [RETURN] to finish and exit the screen.



Notes

- Playlists cannot be created while recording.
- You are allowed a maximum of 99 playlists, with approximately 1000 chapters per playlist.

Editing Playlists/Chapters

Properties

RAM -RW(VR)

Playlist information (e.g., length and date) is shown.

Perform steps 1 – 4c of "Accessing the Playlist View" (→ left).

- 5 Press [▲, ▼] to select "Properties", then press [OK].



Tips

To exit the screen
Press [OK].

Delete

RAM

Use to delete unneeded playlists.

Important: Once deleted, playlists contents cannot be recovered (titles are not affected).

Perform steps 1 – 4c of "Accessing the Playlist View" (→ left).

- 5 Press [▲, ▼] to select "Delete", then press [OK].
- 6 Press [◀] to select "Delete", then press [OK] to confirm.



Tips

To delete during play

1. Press [* DELETE]. A confirmation message displays.
2. Press [◀] to select "Delete", then press [OK] to confirm.

Edit

RAM

You can create and copy playlists, and change thumbnail. Perform steps ① – ④ of “Accessing the Playlist View” (→ 44).

- ⑤ Press [▲, ▼] to select “Edit”, then press [OK].
- ⑥ Press [▲, ▼] to select desired operation from the menu displayed location then press [OK] (→ below).

Create	① Press [▲, ▼] to select “Create”, then press [OK]. (→ 44, Creating Playlists)
Copy	① Press [▲, ▼] to select “Copy”, then press [OK]. ② Press [◀] to select “Copy”, then press [OK].
Enter Name	① Press [▲, ▼] to select “Enter Name”, then press [OK]. ② Enter a name for the playlist. (→ 40, Entering Text)
Change Thumbnail	① Press [▲, ▼] to select “Change Thumbnail”, then press [OK]. ② Press [▶ PLAY], Time Slip (→ 33), Slow-motion (→ 33), or Search (→ 32) to find the desired point. ③ Press [OK] at the image you wish you use for your thumbnail. ④ Press [▲, ▼] to select “Finish”, then press [OK]. – The thumbnail picture is now changed.



Tips

To exit the menu screens
Press [EXIT].

Multiple editing
(Only Delete, Copy)
Select with [▲, ▼, ◀, ▶] and press [||| PAUSE]. (Repeat.)
– A check mark appears. Press [||| PAUSE] again to cancel.

Chapter View

RAM

You can add, move, divide, combine or delete chapters in the playlist.

Perform steps ① – ④ of “Accessing the Playlist View” (→ 44).

- ⑤ Press [▲, ▼] to select “Chapter View”, then press [OK].
- ⑥ Press [▲, ▼, ◀, ▶] to select a chapter.
– Multiple editing (→ right, Tips)
- 7a **To play**
Press [OK].
- 7b **To edit**
Press [OPTION] to display the menu list.

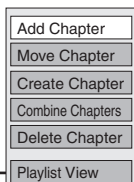

→ Refer to “Chapter Operations” (→ right).

You can go back to the Playlist View.

Chapter Operations

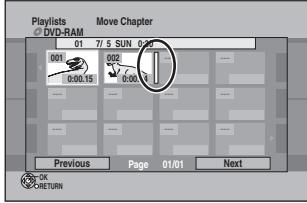
Add Chapter	① Press [▲, ▼] to select “Add Chapter”, then press [OK]. (→ 44, Creating Playlists)
Move Chapter	① Press [▲, ▼] to select “Move Chapter”, then press [OK]. ② Press [▲, ▼, ◀, ▶] to select the position to insert the chapter and press [OK]. 
Create Chapter	① Press [▲, ▼] to select “Create Chapter”, then press [OK]. ② Press [▶ PLAY], Time Slip (→ 33), Slow-motion (→ 33), or Search (→ 32) to find the desired point. ③ Press [OK] at the point you want to divide. ④ Press [▲, ▼] to select “Finish”, then press [OK].
Combine Chapters	① Press [▲, ▼] to select “Combine Chapters”, then press [OK]. ② Press [◀] to select “Combine”, then press [OK]. – The selected chapter gets combined with the next chapter.
Delete Chapter	① Press [▲, ▼] to select “Delete Chapter”, then press [OK]. ② Press [◀] to select “Delete”, then press [OK].



Tips

To exit the menu screens
Press [EXIT].

To view other pages
Press [▲, ▼, ◀, ▶] to select “Previous” or “Next” and press [OK].
– You can also press [◀◀, ▶▶] to view other pages.

Multiple editing
(Only Delete Chapter)
Select with [▲, ▼, ◀, ▶] and press [||| PAUSE]. (Repeat.)
– A check mark appears. Press [||| PAUSE] again to cancel.

For quicker editing
– To skip to the start or end of a playlist/chapter, press [◀◀] (start) or [▶▶] (end).

Setting On-Screen Display

Accessing the On-Screen Display

When playing discs (except for JPEG discs), you can display and set the options including disc audio, subtitle, image quality, sound effect, Repeat Play, etc. In addition, when receiving the multi-channel broadcast, you can change the audio settings.

Menu options will differ based on disc type and contents.

1 Press [DISPLAY].

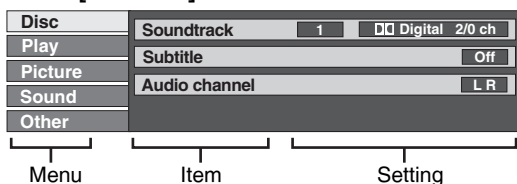

2 Press [▲, ▼] to select a menu, then press [▶].

3 Press [▲, ▼] to select an item, then press [▶].

4 Press [▲, ▼] to select a setting.

Follow the on-screen prompts to change individual settings.



Notes

Some settings may not be changeable, based on the unit's current activity (playing, stopped, etc.) and disc contents.



Tips

To exit the on-screen display
Press [DISPLAY].

Disc Menu

RAM -R -R DL -RW(V) +R +R DL +RW DVD-V -RW(VR) VCD

You can change the settings of disc audio, subtitle, etc.

Soundtrack

RAM -R -R DL -RW(V) +R +R DL +RW -RW(VR)

The disc's audio attributes appear.

(→ below, Audio attributes)

DVD-V

Select the audio and language.

(→ below, Audio attributes, Sound track/Subtitle language)

VCD (SVCD only)

Select the soundtrack number.

- Soundtrack numbers are displayed even when there is only one audio type.

Subtitle

RAM -R -R DL -RW(V) +R +R DL +RW -RW(VR)

(Only discs that contain subtitle on/off information)

Turn the subtitle on/off.

- Subtitle on/off information cannot be recorded using this unit.

DVD-V

Turn the subtitle on/off and select the language (→ below, Sound track/Subtitle language).

VCD (SVCD only)

Turn the subtitle on/off and select the subtitle number.

- Subtitle numbers are displayed even if there are not multiple subtitles.

Audio channel **RAM -RW(VR) VCD**

Change audio during playback.

LR / L / R

Angle **DVD-V**

Change the number to select an angle.

PBC (Playback control → 72) **VCD**

Indicates whether menu play (playback control) is on or off.

Sound track/Subtitle language

ENG: English	CHI: Chinese
FRA: French	KOR: Korean
DEU: German	MAL: Malay
ITA: Italian	VIE: Vietnamese
ESP: Spanish	THA: Thai
NLD: Dutch	POL: Polish
SVE: Swedish	CES: Czech
NOR: Norwegian	SLK: Slovak
DAN: Danish	HUN: Hungarian
POR: Portuguese	FIN: Finnish
RUS: Russian	*: Others
JPN: Japanese	

Audio attributes

LPCM/Digital/DTS/MPEG: Signal type

k (kHz): Sampling frequency

b (bit): Number of bits

ch (channel): Number of channels



Notes

- You cannot make a change when there is no recording.
- Some discs allow changes to soundtracks, subtitles, and angles only by using the disc's menus (→ 17).

Play Menu

RAM -R -R DL -RW(V) +R +R DL +RW DVD-V
-RW(VR) CD VCD

Repeat Play

This function works only when the elapsed play time is displayed.

Select the item for repeat play. Depending on the disc, the items that can be selected will differ.

Select "Off" to cancel.

Picture Menu

RAM -R -R DL -RW(V) +R +R DL +RW DVD-V
-RW(VR)

You can change the progressive output setting and the noise reduction setting when playing discs or of images from the connected device.

Playback NR

"On" reduces noise and picture degradation.

Progressive [Only when you have set "Progressive" to "On" in the Setup menu (→ 54)]

Select "On" to enable progressive output.

- Select "Off" if the picture is stretched horizontally.

Transfer [Only when you have selected "On" in "Progressive" (→ above)]

Select the method of conversion for progressive output to suit the type of material being played.

When the output signal is PAL

(When the tray is opened, the setting will return to "Auto".)

- Auto: Automatically detects the film and video content, and appropriately converts it.
- Video: Select when using "Auto", and the content is distorted.
- Film: Select this if the edges of the film content appear jagged or rough when "Auto" is selected.



However, if the video content is distorted as shown in the illustration to the above, then select "Auto".

When the output signal is NTSC

- Auto1 (normal): Automatically detects the film and video content, and appropriately converts it.
- Auto2: In addition to "Auto1", automatically detects film contents with different frame rates and appropriately converts it.
- Video: Select when using "Auto1" and "Auto2", and the content is distorted.

Input NR

(Only when AV1, AV2, AV3 or DV is selected)
Reduces video tape noise during recording. Depending on the video signal, jittering may occur.

- Automatic: Noise reduction only works on picture input from a video tape.
- On: Noise reduction works for any video input.
- Off: Noise reduction is off. Select when you want to record input as is.

Sound Menu

You can change the settings of audio when receiving the multi-channel broadcast, and also change the settings of sound effect when playing discs.

DVB Multi Audio

(MPEG Audio only)

If more than one audio channels are output, you can set the desired channel before recording.

- DVB Multi Audio cannot be selected during playback or recording.
- Depending on the broadcast, the items that can be selected will differ.

English 1/ English 2

RAM -R -R DL -RW(V) +R +R DL +RW DVD-V
-RW(VR)

V.S.S. (Dolby Digital, MPEG Audio with 2.0 or over channels only)

- This function does not work for bilingual recordings.
- Enjoy a surround-sound effect if you are using 2 front speakers (L/R) only.
- Turn off if it causes distortion.

Natural / Emphasis / Off

Dialog Enhancer (Dolby Digital, 3-channel or over only, including a centre channel)

When "On", the volume of the centre channel is raised to make dialogue easier to hear.

Other Menu

Position

Change where this menu screen appears on your TV.

DVD Management

You can manage discs through formatting, finalising and other operations.

Accessing the Management Menus

Preparation:

- **RAM** Release protection (disc, cartridge → below).
- Insert a disc.

With the unit stopped

- 1 Press [FUNCTION MENU].
- 2 Press [▲, ▼] to select “To Others”, then press [OK].

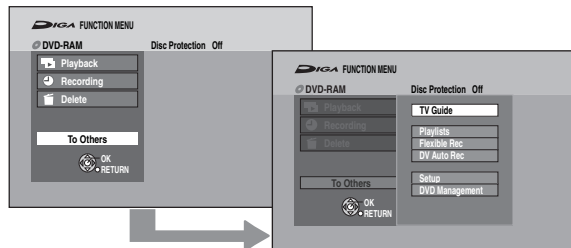

- 3 Press [▲, ▼] to select “DVD Management”, then press [OK].



Tips

To return to the previous screen

Press [RETURN].

To exit the screen

Press [EXIT].

Setting Protection

RAM

Use to prevent accidental erasure of disc.

Perform preparation steps 1 – 3 of “Accessing the Management Menus” (→ above).

- 4 Press [▲, ▼] to select “Disc Protection”, then press [OK].
- 5 Press [◀] to select “Yes”, then press [OK].

Protection of cartridge disc

RAM (With a cartridge)

With the write-protect tab in the protect position, you cannot record to, edit, format or erase from the disc.



Naming Discs

RAM -R -R DL -RW(V) +R +R DL +RW

You can give a name for the disc.

Perform preparation steps 1 – 3 of “Accessing the Management Menus” (→ above).

- 4 Press [▲, ▼] to select “Disc Name”, then press [OK].
 - Entering Text (→ 40).



Tips

- The disc name is displayed in the DVD Management window.
- With a finalised discs and +RW created Top Menu, the name is displayed on the Top Menu.

Deleting All Titles

You can delete all titles on the single-sided DVD-RAM at once.

Important: Once deleted, contents cannot be recovered.

RAM

Perform preparation steps 1 – 3 of “Accessing the Management Menus” (→ left).

- 4 Press [▲, ▼] to select “Delete all titles”, then press [OK].
- 5 Press [◀] to select “Yes”, then press [OK].
- 6 Press [◀] to select “Start”, then press [OK].
 - A message appears when deleting is finished.
- 7 Press [OK] to complete.



Notes

Deleting does not work if one or more titles are protected.

Formatting Discs

RAM -RW(V) +RW -RW(VR)

+R +R DL (New disc only)

Formatting is the process of making media such as DVD-RAM recordable on recording equipment.

You can record or edit after formatting the finalised DVD-RW.

Important: Once formatted, contents cannot be recovered.

Perform preparation steps 1 – 3 of “Accessing the Management Menus” (→ left).

- 4 Press [▲, ▼] to select “Format Disc”, then press [OK].
- 5 Press [◀] to select “Yes”, then press [OK].
- 6 Press [◀] to select “Start”, then press [OK].
 - Formatting starts (**RAM** may take up to a maximum of 70 minutes).
 - A message appears when formatting is finished.
- 7 Press [OK] to complete.



Notes

- Do not disconnect the AC mains lead while formatting. This can render the disc unusable.
- When a disc has been formatted using this unit, it may not be possible to use it on any other equipment.
- **-R -R DL** Formatting cannot be performed.
- **-RW(V) -RW(VR)** You can format only as DVD-Video format on this unit.
- **RAM** Pressing [RETURN] during format will cancel the process. The disc must be reformatted if you do this.
- **RAM** The disc cannot be formatted if the write-protect tab (→ left) is switched to “PROTECT”. Release the protection to continue.
- The message “Unable to format” appears when trying to format discs the unit cannot use.

Selecting Whether to Show the Top Menu First

-R -R DL -RW(V) +R +R DL +RW

Before finalising a disc, select whether the top menu shows after finalising.

Perform preparation steps ① – ③ of “Accessing the Management Menus” (→ 48).

- ④ Press [**▲**, **▼**] to select “Auto-Play Select”, then press [OK].
- ⑤ Press [**▲**, **▼**] to select “Top Menu” or “Title 1”, then press [OK].
 - Top Menu:
The Top Menu appears first.
 - Title 1:
The disc content is played without displaying the Top Menu.

Finalising

-R -R DL -RW(V) +R +R DL

You can play these discs on compatible DVD players by finalising it on the unit, effectively making it into DVD-Video that complies with DVD-Video standards. The menu you create with the unit can also be used on most DVD players.

Perform preparation steps ① – ③ of “Accessing the Management Menus” (→ 48).

- ④ Press [**▲**, **▼**] to select “Finalise”, then press [OK].
- ⑤ Press [**◀**] to select “Yes”, then press [OK].
- ⑥ Press [**◀**] to select “Start”, then press [OK].
 - Finalising starts and cannot be cancelled. (may take up to 15 minutes) (**-R DL +R DL** up to 60 minutes)
 - A message appears when finalising is finished.
- ⑦ Press [OK] to complete.



Notes

- Do not disconnect the AC mains lead while finalising. This can render the disc unusable.
- When finalising a high-speed recording compatible disc, it may take longer than displayed on the confirmation screen (approximately 4 times longer).
- After finalising
 - **-R -R DL +R +R DL** The disc becomes play-only and you can no longer record or edit it.
 - **-RW(V)** You can record and edit the disc after formatting although it becomes play-only after finalising.
 - The disc finalised on the unit may not be playable on other players depending on the condition of the recording.
 - There is a pause of several seconds between titles and chapters during playback.
 - Titles are divided into about 5-minute chapters (**+R +R DL** 8 minutes)*.

※ This time varies greatly depending on the condition and mode of recording.



Tips

After you have finished recording and try to eject the disc, a screen asking if you want to finalise the disc appears (→ 23).

Create Top Menu

+RW

+RW discs contain no Top Menu data. Top Menu is a convenient function. We recommend you create the menu before playing a +RW disc on other equipment.

Perform preparation steps ① – ③ of “Accessing the Management Menus” (→ 48).

- ④ Press [**▲**, **▼**] to select “Create Top Menu”, then press [OK].
- ⑤ Press [**◀**] to select “Yes”, then press [OK].
- ⑥ Press [**◀**] to select “Start”, then press [OK].
 - “Create Top Menu” cannot be cancelled once started.
 - “Create Top Menu” takes a few minutes.
- ⑦ Press [OK] to complete.



Notes

- Recording or editing on the disc may delete the Top Menu. In that case, create the Top Menu again.
- You cannot use the Top Menu for playing on this unit.

Enabling the Second Layer on DL (Dual- or Double-Layer on Single Side) Discs to be Recordable

-R DL +R DL

DVD-R DL and +R DL discs have two layers of recording surface on one side. As this unit does not offer seamless recording on two layers, recording stops when space on the first layer becomes full. You must close the first layer to start recording on the second layer. Closing makes the first layer unavailable for recording (editing is still possible).

Perform preparation steps ① – ③ of “Accessing the Management Menus” (→ 48).

- ④ Press [**▲**, **▼**] to select “Close First Layer”, then press [OK].
- ⑤ Press [**◀**] to select “Yes”, then press [OK].
- ⑥ Press [**◀**] to select “Start”, then press [OK].
- ⑦ Press [OK] to complete.



Notes

- The first layer cannot be closed when there is no recording on it.
- Closing cannot be cancelled once started.
- Do not disconnect the AC mains lead while closing the layer. This can render the disc unusable.
- Closing takes several minutes, up to a maximum of 30 minutes, depending on the remaining space on the first layer.



Tips

You can confirm the remaining recording time on the layer in the DVD Management screen.

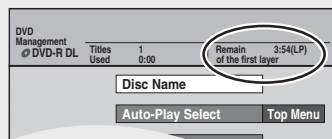

Setup Menu

You can change the unit's settings using Setup menu.

Accessing the Setup Menu

With the unit stopped

- 1 Press [FUNCTION MENU].
- 2 Press [▲, ▼] to select "To Others", then press [OK].

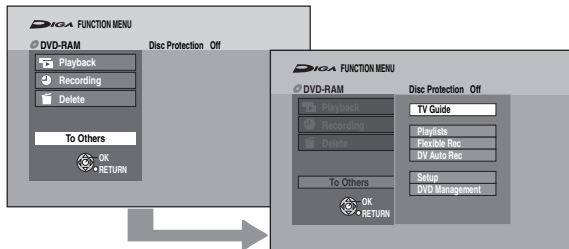

- 3 Press [▲, ▼] to select "Setup", then press [OK].
- 4 Press [▲, ▼] to select a menu, then press [▶] to go to the item list.

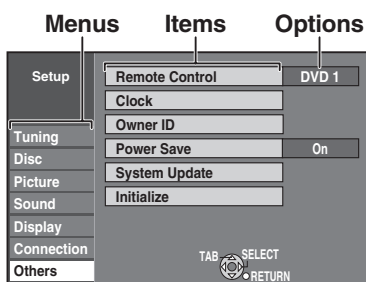

- 5 Press [▲, ▼] to select an item to change, then press [OK].
- 6 Press [▲, ▼] to select an option, then press [OK].

For Setting details, refer to pages 50-56.



Notes

Changed settings remain intact even when switching the unit to standby mode.



Tips

To return to the previous screen

Press [RETURN]. Even if you have changed an option, the change is not activated until you press [OK].

To exit the screen

Press [EXIT].

Channel Settings

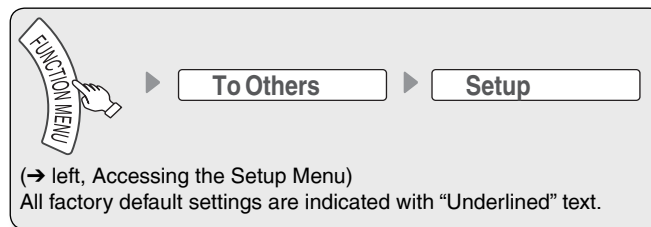

(→ left, Accessing the Setup Menu)

All factory default settings are indicated with "Underlined" text.

Tuning

▲, ▼ select "Tuning" → ▶ → ▲, ▼ select item → [OK]

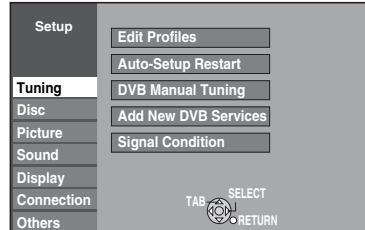

Edit Profiles

You can create four profiles of channels for making viewing and recording easier. Editing these profiles does not affect the channel setting itself.

- Timer recording may not work correctly if you edit the profiles during timer recording standby.
- Channel numbers cannot be changed, due to broadcast restrictions.

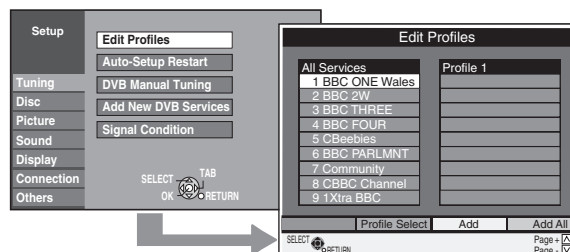

To select the profile

Press the "Green" button.

To add channels to a profile

- 1 Press [▲, ▼] to select the channel in the "All Services" column, then press the "Yellow" button.
 - Repeat this step to add other channels.
 - Press the "Blue" button to add all the available channels to the profile. (Only when no channels have been added to the profile.)
- 2 Press [OK] to save the profile.

To change the order of channels of a profile

- 1 Press [▶]*.
- 2 Press [▲, ▼] to select the channel in the "Profile" column to move, then press the "Green" button.
- 3 Press [▲, ▼] to select the new position of the channel, then press the "Green" button.
 - Repeat the steps 2-3 to move other channels.
- 4 Press [OK] to save the profile.

To delete channels on a profile

- 1 Press [▶]*.
- 2 Press [▲, ▼] to select the channel in the "Profile" column, then press the "Yellow" button.
 - Repeat this step to delete other channels.
 - Press the "Blue" button to delete all the channels from the profile.
- 3 Press [OK] to save the profile.

Deleting a channel from a profile does not affect the channel itself.
You can still select the channel from the "All Services" profile.

To change the name of a profile in the "Profile" column

- 1 Press [▶]*.
- 2 Press the "Red" button.

(→ 40, Entering Text)

* When the station name of the "All Services" column is highlighted



Tips

To browse through the list
Press [^, v CH].

Auto-Setup Restart

You can restart auto channel setting for digital terrestrial channels if set up (→ 11) fails for some reason.

However, if you perform “Auto-Setup Restart”, all channel settings and all created profiles are deleted.

Press [◀] to select “Yes”, then press [OK].



Tips

- You can also use the following method to restart Auto-Setup. (All the settings except for the ratings level, ratings password, Owner ID and Clock return to the factory preset. The timer recording programmes are also cancelled.)

When the unit is turned on and stopped, press and hold [v CH] and [CH ^] on the main unit at the same time for about 5 seconds.

Auto-Setup screen appears.

DVB Manual Tuning

You can set channels manually if the DVB Auto-Setup could not complete successfully.

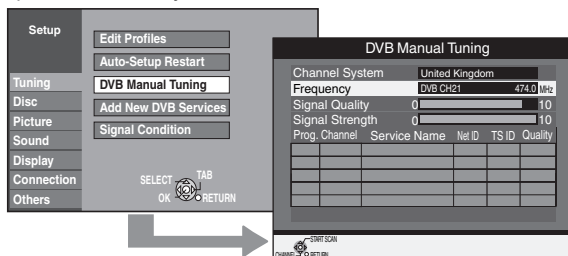

1. Press [▲, ▼] to select the channel you want to set.

- Select the channel by checking the signal strength and signal quality displays.

[Refer to “Signal Condition” (→ right) for signal strength and signal quality.]

2. Press [OK] to start scan.

The set channel is displayed in the table.

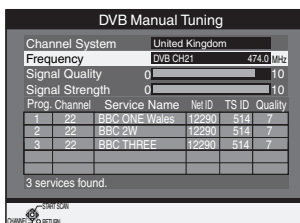

3. Press [EXIT] and press [^, v CH], check that applicable channels have been selected.

Add New DVB Services

You can search for newly added digital terrestrial channels to receive.

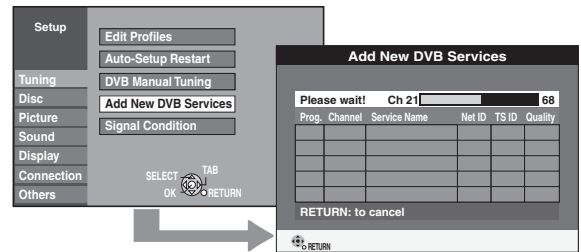

- The unit starts searching for newly available digital terrestrial channels. This takes about 5 minutes.

- The bar over the table shows you the search progress.

At the end of the search, the number of found new digital stations appears.

- “No new services found.”, is displayed when no new services can be found.

Press [OK] to save the newly found channels.



Tips

To cancel in middle

Press [RETURN].

The channels found before stopping are not saved.

Signal Condition

You can check the quality and strength of digital broadcast signals. Realign the aerial if you are receiving a poor signal.

When “Signal Condition” is displayed in grey and cannot be selected:

- Press [EXIT] to exit the screen.
- Press [^, v CH] to select a digital channel. “D” appears on the unit’s display.
- Display the Setup menu again.

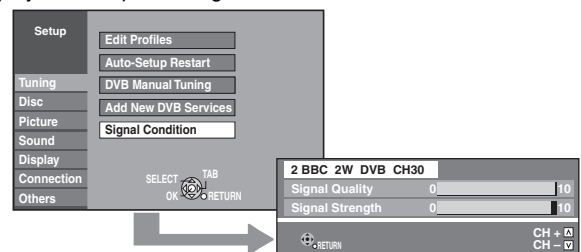

The quality and strength of the signal are shown.

Press [^, v CH] to select the other channel.

Signal Quality

Below 2 (display red)	The signal quality is so poor that there may be interference in the pictures and sound.
2–5 (display orange)	The signal quality is basically adequate, but brief interference in the pictures and sound is possible in isolated case.
Over 5 (display green)	Optimum picture and sound quality.

Signal Strength

The display for signal strength is grey. “0” means signal strength 0%, “10” means signal strength 100%.

If the signal is too strong, the display will change from grey to red. Reduce the signal amplification at your aerial.

- When the signal is weak:

- check that the aerial is correctly positioned.
- adjust the aerial reception with “DVB Manual Tuning” in the Setup menu (→ left).
- check that the current digital broadcast channel is correctly broadcasting.

Playback/Recording Settings

(→ 50, Accessing the Setup Menu)
All factory default settings are indicated with "Underlined>" text.

Disc

▲, ▼ select "Disc" → ► → ▲, ▼select item → OK

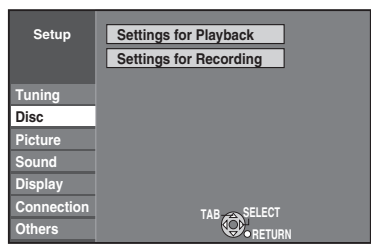

Settings for Playback

Press [OK] to show the following settings.

Ratings
Set a ratings level to limit DVD-Video play. Follow the on-screen instructions. Enter a 4-digit password with the numbered buttons when the password screen is shown. Do not forget your password.

- Setting ratings (When level 8 is selected)
 - [8 No Limit]: All DVD-Video can be played.
 - [1] to [7]: Prohibits play of DVD-Video with corresponding ratings recorded on them.
 - [0 Lock All]: Prohibits play of all DVD-Video.
- Changing ratings (When level 0 to 7 is selected)
 - [Unlock Recorder] [Change Password] [Change Level] [Temporary Unlock]

Soundtrack
[English] [German] [French] [Italian] [Spanish] [Original]
[Other ****]

Subtitle
[Automatic] [English] [German] [French] [Italian] [Spanish]
[Other ****]

Menus
[English] [German] [French] [Italian] [Spanish] [Other ****]

Notes

DVD-V Choose the language for audio, subtitles and disc menus. If a language which is not recorded is selected, or if languages are already fixed on the disc, the language set as the default on the disc will be played instead.

- [Original] The original language of each disc will be selected.
- [Other ****] This is the language code setting. Input a code number with the numbered buttons (→ 62, "Language code list").
- [Automatic] If the language selected for "Soundtrack" is not available, subtitles of that language will automatically appear if available on the disc.

Settings for Recording

Press [OK] to show the following settings.

Recording time in EP mode
Select the maximum number of hours for recording in EP mode.

- [EP (6Hours)]: You can record for 6 hours on an unused 4.7 GB disc.
- [EP (8Hours)]: You can record for 8 hours on an unused 4.7 GB disc.

Picture Settings

(→ 50, Accessing the Setup Menu)
All factory default settings are indicated with "Underlined>" text.

Picture

▲, ▼ select "Picture" → ► → ▲, ▼select item → OK

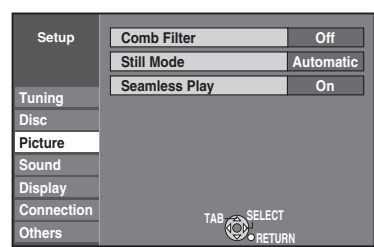

Comb Filter
Select the picture sharpness when recording. The setting is fixed with "On" if you set "TV System" to "NTSC" (→ 55).

- [On] Select it to record clear picture.
- [Off] Normally, use this setting.

Still Mode
Select the type of picture shown when you pause play. (→ 72, "Frame and Field")

- [Automatic] Select if jittering occurs when "Automatic" is selected.
- [Field] Select if you cannot see small text or fine patterns clearly when "Automatic" is selected.

Seamless Play
Select the play mode between playlist chapter segments and partially deleted titles.

- [On] The chapters in playlists are played seamlessly. This does not work when there are several audio types included on the playlist and when using Quick View (Play x1.3). Additionally, the positioning of chapter segments may change slightly.
- [Off] The points where chapters in playlists change are played accurately, but the picture may freeze for a moment.

Sound Settings

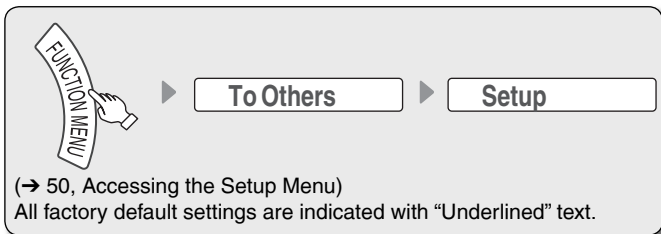

Sound

▲, ▼ select “Sound” → ► → ▲, ▼ select item → OK

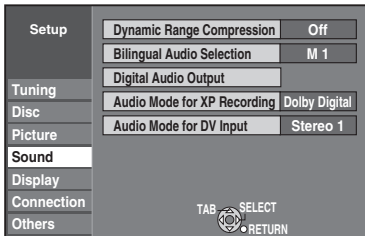

Dynamic Range Compression

DVD-V (Dolby Digital only)

Change the dynamic range (→ 72) for easier listening in low volume.

[On] [Off]

Bilingual Audio Selection

-R -R DL -RW(V) +R +R DL +RW

When recording bilingual programmes from equipment connected to the DV IN terminal of this unit, select whether to record the main or secondary audio type.

[M 1] [M 2]

Digital Audio Output

Change the settings when you have connected equipment through the unit's DIGITAL AUDIO OUT terminal (→ 60).

Press [OK] to show the following settings.

PCM Down Conversion

Select how to output audio with a sampling frequency of 96 kHz or 88.2 kHz.

Signals are converted to 48 kHz or 44.1 kHz despite the above settings if the signals have a sampling frequency of over 96 kHz or 88.2 kHz, or the disc has copy protection.

[On] Signals are converted to 48 kHz or 44.1 kHz. (Choose when the connected equipment cannot process signals with sampling frequency of 96 kHz or 88.2 kHz.)

[Off] Signals are output as 96 kHz or 88.2 kHz. (Choose when the connected equipment can process signals with sampling frequency of 96 kHz or 88.2 kHz.)

Dolby Digital ※

Choose whether to output by “Bitstream” which processes Dolby Digital signals on other connected equipment or to convert the signals to “PCM (2ch)” on the unit before output.



[Bitstream] When you have connected the unit to a piece of equipment having Dolby Digital logo.

[PCM] When you have connected the unit to a piece of equipment that doesn't have Dolby Digital logo.

DTS ※

Choose whether to output by “Bitstream”, which processes DTS signals on other connected equipment or to convert the signals to “PCM (2ch)” on the unit before output.



[Bitstream] When you have connected the unit to a piece of equipment having DTS logo.

[PCM] When you have connected the unit to a piece of equipment that doesn't have DTS logo.

MPEG ※

Choose whether to output by “Bitstream”, which processes MPEG audio signals on other connected equipment or to convert the signals to “PCM (2ch)” on the unit before output.

[Bitstream] When you have connected the unit to a piece of equipment with a built-in MPEG decoder.

[PCM] When you have connected the unit to a piece of equipment without a built-in MPEG decoder.

Audio Mode for XP Recording

Choose the audio type when recording with XP mode.

[Dolby Digital] (→ 72)

[LPCM] (→ 72)

- The picture quality of LPCM recordings may be lower than that of normal XP mode recordings.

- The audio recording becomes Dolby Digital even if you selected LPCM when using a recording mode other than XP.

Audio Mode for DV Input

You can select the kind of audio when recording from the unit's DV IN terminal (→ 26).

[Stereo 1] Records audio (L1, R1)

[Stereo 2] Records added audio such as narration (L2, R2) subsequent to original recording.

[Mix] Records both Stereo 1 and Stereo 2.

When recording bilingual broadcast, select the type of audio in advance from “Bilingual Audio Selection” (→ left).

※ Incorrect settings can cause noise to be output which can be harmful to your ears and speakers, and audio will not be recorded properly on media such as mini discs.

Display and Connection Settings

(→ 50, Accessing the Setup Menu)
All factory default settings are indicated with "Underlined>" text.

Display

▲, ▼ select "Display" → ► ► ► ▲, ▼select item → OK

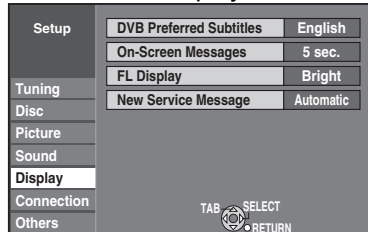

DVB Preferred Subtitles

Choose the subtitle language for digital broadcast.
If the selected subtitle is not available, then the available subtitle will be shown.

[English] [Welsh] [Gaelic]
[English for hearing impaired]
[Welsh for hearing impaired]
[Gaelic for hearing impaired]

On-Screen Messages

Choose the approximate time until the digital channel information screen (→ 36) disappears automatically.

The length of time the control panel (→ 39) is displayed can also be changed, but "Off" does not work.

[Off] The digital channel information is not displayed.
[3 sec.] [5 sec.] [7 sec.] [10 sec.]

FL Display

Changes the brightness of the unit's display.

Regardless of the setting, when "Power Save" (→ 56) is "On" and this unit is turned off, the unit's display is turned off.

[Bright]
[Dim]

New Service Message

When a new DVB channel is added, this unit will be informed automatically. Then the confirmation message appears. If you select "Yes" on the display, Auto-Setup starts (All channel settings and all created profiles are deleted. The timer recording programmes are also cancelled.)

[Automatic]
[Off] The Service Messages are not shown.

Connection

▲, ▼ select "Connection" → ► ► ► ▲, ▼select item → OK

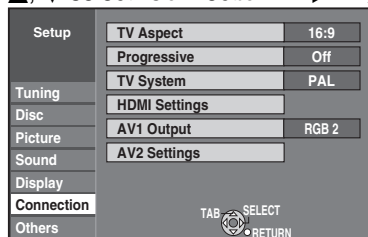

TV Aspect

This setting needs to be changed when connected to a 4:3 standard aspect TV.

Press [▲, ▼] to select the TV Aspect, then press [OK].
[16:9] [4:3] [Letterbox]

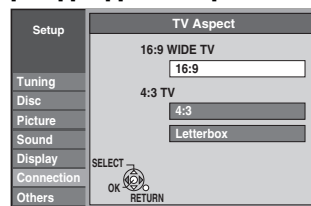

Notes

• Aspect 4:3/16:9

4:3

16:9

4:3 standard aspect television 16:9 widescreen television

- 16:9: When connected to a 16:9 widescreen television. However, the 4:3 aspect ratio picture expands left and right.

- 4:3: When connected to a 4:3 aspect television, side picture is trimmed for 16:9 picture (→ 72, Pan & Scan).



- **Letterbox:** When connected to a 4:3 aspect television, widescreen picture is shown in the letterbox style (→ 72).



Progressive

You can enjoy progressive video by connecting this unit's COMPONENT VIDEO OUT terminals to an LCD/plasma television or LCD projector compatible with progressive scan (→ 73).

Before this setting, set "AV1 Output" to "Video (with component)" or "S Video (with component)" (→ 55).

Press [▲, ▼] to select "On", then press [OK].

[On] Output becomes progressive.

[Off]

This setting is fixed with "Off" and there is no output from the COMPONENT VIDEO OUT terminals if you set "AV1 Output" to "RGB 1 (without component)" or "RGB 2 (without component)" (→ 55).



Notes

- When connected to a regular television (CRT: cathode ray tube) or a multi-system television using PAL mode, even if it is progressive compatible, progressive output can cause some flickering. Turn off "Progressive" if this occurs (→ 47).
- Picture will not be displayed correctly if connected to an incompatible television.

TV System

Change this setting if you connect an NTSC television or to record NTSC video from another source.

1. Press **[▲, ▼]** to select the TV System, then press **[OK]**.

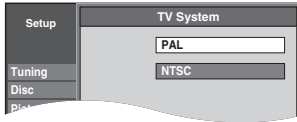

[PAL]

- Select when connecting to a PAL or Multi-system television. Programmes recorded using NTSC are played as PAL 60.
- Select to record television programmes and PAL input from other equipment.

[NTSC]

- Select when connecting to an NTSC television. Television programmes cannot be recorded properly.
- Select to record NTSC input from other equipment.

The confirmation screen appears.

2. Press **[◀]** to select “Yes”, then press **[OK]**.



Tips

To change the setting all at once (PAL ↔ NTSC)

While stopped, press and hold **[■]** and **[▲ OPEN/CLOSE]** on the main unit at the same time for about 5 seconds.

HDMI Settings^{※1}

- Press **[OK]** to show the following settings.

HDMI Video Format^{※2}

You can only select items compatible with the connected equipment. If you are concerned about output picture quality, it may be improved by changing the setting.

- To enjoy High Quality Video up-converted to 1080p, you need to connect the unit directly to 1080p compatible HDTV. If this unit is connected to an HDTV through other equipment, it must also be 1080p compatible.

[576i/480i] [576p/480p] [720p] [1080i]

[1080p] When outputting 1080p signal, we recommend using High Speed HDMI Cables that have the HDMI logo (as shown on the cover) and are less than 5 meters to prevent video distortion etc.

[Automatic] Automatically selects the output resolution best suited to the connected television (1080p, 1080i, 720p, 576p/480p or 576i/480i).

Aspect for 4:3 Video

To play a 4:3 title when connected with an HDMI cable, set how to show pictures on a 16:9 widescreen television. 4:3 picture from HDMI output will be slightly smaller than that from the other outputs, e.g. Scart and component, this is not a malfunction of the unit.

[4:3] Picture output expands left or right.



[16:9] Picture is output as original aspect with side panels.



Digital Audio Output

[HDMI and Optical]

[Optical Only] Select when this unit is connected to an amplifier with an optical digital audio cable (→ 60) and connected to a TV with an HDMI cable (→ 10) and you want to enjoy the highest quality of audio from discs.

VIERA Link

[On]

[Off] Select when you do not want to use “HDAVI Control”.

AV1 Output

Set according to the terminal of the connected TV. Select “Video (with component)” or “S Video (with component)” for component output (progressive output). Set according to the signal and terminal of the connected TV.

[Video (with component)]

Select when a TV is connected that can receive a composite signal.

[S Video (with component)]

Select when a TV is connected that can receive an S Video signal.

[RGB 1 (without component)]

Select when a TV is connected that can receive an RGB signal. If you always would like to view the picture from the unit in RGB signal, select this mode. The TV screen will automatically switch to display the picture from the unit when the unit is turned on.

[RGB 2 (without component)]

Select when a TV is connected that can receive an RGB signal. If you would like to switch to display the picture from the unit only when playback or viewing menus, select this mode.

- If this unit is connected with an HDMI cable, you cannot select “RGB 1 (without component)” or “RGB 2 (without component)”.

AV2 Settings

Set to match the connected equipment.

- Press **[OK]** to show the following settings.

AV2 Input

Set to “RGB/Video” or “RGB” when receiving or recording RGB output from external equipment.

[RGB/Video] The unit automatically detects whether the input signal from the AV2 terminal is an RGB signal or other signals and makes settings.

[RGB]

[Video]

[S Video]

Ext Link

This setting cannot be made when the “TV System” is set to “NTSC” (→ left).

[Ext Link 1] When this unit is connected to a satellite receiver with a 21-pin Scart cable and this unit receives a control signal.

Start and stop timings of recording are controlled by the control signal.

[Ext Link 2] When external equipment with a timer function is connected.

Recording is continued while the image signal is being sent to the unit from the external equipment.

Recording is stopped when the image signal is halted by turning the external equipment off.

※1 Depending on the connected equipment, some items may be shaded in grey on the display and cannot be selected, or you may not be able to change the settings.

※2 Choose the setting to suit your TV and preference.

System Settings

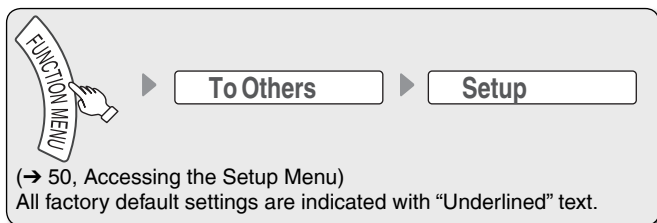

Others

▲, ▼ select “Others” → ► ► ► ▲, ▼ select item → OK

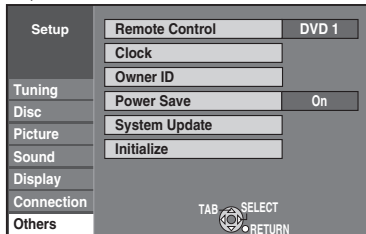

Remote Control (→ 65)

[DVD 1] [DVD 2] [DVD 3]

Clock (→ 12)

Owner ID (→ 11)

In order to prevent another person from using this unit if it is stolen, you can set a PIN number and input your personal information.

Once the PIN number has been set, you cannot return to the factory preset. Make sure not to forget this.

- PIN number
- Name
- House No.
- Postcode

Power Save

[On] [Off]

Refer to the following when “Power Save” is set to “On”.

- Power consumption is minimized when the unit is turned off (→ 74).
- Startup of the unit becomes slower compared to when “Power Save” is “Off”.
- When the unit is off, satellite programmes cannot be watched on the TV because the signal from the satellite receiver connected to AV2 input terminal of this unit is not looped through. To watch them, turn on the unit.

System Update

In order to update this unit, the TV Guide download, and support system changes made by broadcasts, this unit periodically performs software updates.

- Press [OK] to show the following settings.
- Update data and TV Guide download information are sent by an unscheduled digital broadcast. In order to receive these updates, you must be able to receive digital broadcasts.
- An update will take approximately 60 minutes. While the update is in progress, “SW-DL” appears on the unit’s display. You cannot operate the unit until the update is complete. Removing the AC mains lead while the update is in progress may damage the unit.
- A TV Guide download will take approximately 30 minutes. While the TV Guide download is in progress, “GUIDE” appears on the unit’s display. The TV Guide download can be interrupted by switching on the unit.
- To avoid hearing the startup sound of System Update for the unit, perform the following steps.
 - Select the time for Software Update (→ below, TV Guide/ Software search period).
 - Set “TV Guide Download in Standby” and “Software Update in Standby”(→ below) to “Off”, and update manually (→ below, Software Update Search Now).

TV Guide Download in Standby

[On] When the unit is turned off, TV Guide data is downloaded automatically.

[Off]

Software Update in Standby

[On] You can perform the unit updates automatically when the unit is turned off.

[Off]

TV Guide/Software search period

Selects the time to automatically perform TV Guide download and updates when the unit is turned off. This can only be set when “TV Guide Download in Standby” and “Software Update in Standby” is set to “On”.

- If there is a programmed recording set for the time you have selected, the programmed recording will be given priority.

[Automatic] The unit will give priority to searching for update data at midnight.

[02:00-06:00] [06:00-10:00] [10:00-14:00]

[14:00-18:00] [18:00-22:00] [22:00-02:00]

Software Update Search Now

Start the search for new software manually.

A new software version is announced by a message. Do not switch your unit off during the update. This could result in the loss of data. A message shows that the update has finished. If a new software version is not going to be broadcast until the next few days, a corresponding message also appears.

- If applicable update data is found, press [◀, ▶] to select “Yes” and press [OK].

Initialize

Press [OK] to show the following settings.

Shipping Condition

This returns Setup menus to default settings, except for the ratings level, ratings password, Owner ID and Clock setting.

[Yes] [No]

- The timer recording programmes are also cancelled.

Default Settings

This returns Setup menus to default settings, except for the programmed channels, time settings, disc language settings, ratings level, ratings password, Owner ID and remote control code.

[Yes] [No]

Other Settings

Child Lock

The Child Lock deactivates all buttons on the unit and remote control. Use it to prevent other people from operating the unit.

Press and hold [OK] and [RETURN] at the same time until "X HOLD" appears on the unit's display.



If you press a button while the Child Lock is on, "X HOLD" appears on the unit's display and operation is impossible.



Tips

To cancel the Child Lock

Press and hold [OK] and [RETURN] at the same time until "X HOLD" disappears.

Using the Unit's Remote Control to Operate the TV

You can configure the remote control TV operation buttons to turn the television on/off, change the television input mode, select the television channel and change the television volume.

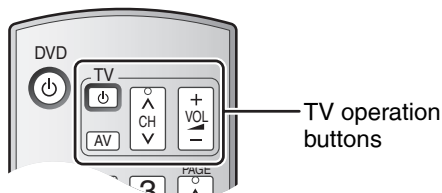

- 1 Point the remote control at the TV.
- 2 While pressing and holding [TV], enter the code from the table below using the numbered buttons.
e.g., 01: press [0] → [1]
- 3 Test the TV functions of the remote control for operability.
 - If the functions do not work, repeat steps 1 to 3 using different codes, if available. Some TVs may not be compatible with the unit's remote control.

Remote Control Codes for the TV

Manufacturer	Code No.
Panasonic	01 / 02 / 03 / 04
AIWA	35
AKAI	27 / 30
BEJING	33
BEKO	05 / 71 / 72 / 73 / 74
BENQ	58 / 59
BP	09
BRANDT	10 / 15
BUSH	05
CENTREX	66
CHANGHONG	69
CURTIS	05
DAEWOO	64 / 65
DESMET	05
DUAL	05
ELEMIS	05
FERGUSON	10 / 34
FINLUX	61

Manufacturer	Code No.
FISHER	21
FUJITSU	53
FUNAI	63 / 67
GOLDSTAR	05 / 50 / 51
GOODMANS	05
GRADIENTE	36
GRUNDIG	09
HIKONA	52
HITACHI	05 / 22 / 23 / 40 / 41
INNO HIT	05
IRRADIO	30
ITT	25
JINGXING	49
JVC	17 / 30 / 39 / 70
KDS	52
KOLIN	45
KONKA	62
LG	05 / 50 / 51
LOEWE	07 / 46
MAG	52
METZ	05 / 28
MITSUBISHI	05 / 19 / 20 / 47
MIVAR	24
NEC	36
NOBLEX	33
NOKIA	25 / 26 / 27 / 60 / 61
NORDMENDE	10
OLEVIA	45
ONWA	30 / 39 / 70
ORION	05
PEONY	49 / 69
PHILCO	41 / 48 / 64
PHILIPS	05 / 06 / 46
PHONOLA	05
PIONEER	37 / 38
PROVIEW	52
PYE	05
RADIOLA	05
SABA	10
SALORA	26
SAMSUNG	32 / 42 / 43 / 65 / 68
SANSUI	05
SANYO	21 / 54 / 55 / 56
SCHNEIDER	05 / 29 / 30
SEG	05 / 69 / 75 / 76 / 77 / 78
SELECO	05 / 25
SHARP	18
SIEMENS	09
SINUDYNE	05
SONY	08
TCL	31 / 33 / 66 / 67 / 69
TELEFUNKEN	10 / 11 / 12 / 13 / 14
TEVION	52
TEX ONDA	52
THOMSON	10 / 15 / 44
TOSHIBA	16 / 57
WHITE	05
WESTINGHOUSE	
YAMAHA	18 / 41

Additional Connections

Using a fully wired 21-pin Scart cable

- You can use a variety of Q Link functions by connecting the unit to a Q Link compatible television (→ 38).
- You can enjoy high-quality viewing by connecting the unit to an RGB compatible television.
“AV1 Output” in the Setup menu is set to “RGB 1 (without component)” or “RGB 2 (without component)” (→ 55)
- “AV2 Input” settings in the Setup menu (→ 55)

Use of the RF coaxial cable

- Keep the RF coaxial cables as far away as possible from other cables.
- Do not roll up the RF coaxial cables.

Before connection, turn off the mains for all connected equipment and read the appropriate operating instructions. Be sure to read the Caution for AC Mains Lead on page 3.

Adding a VCR: Connecting to a Television and a Video Cassette Recorder

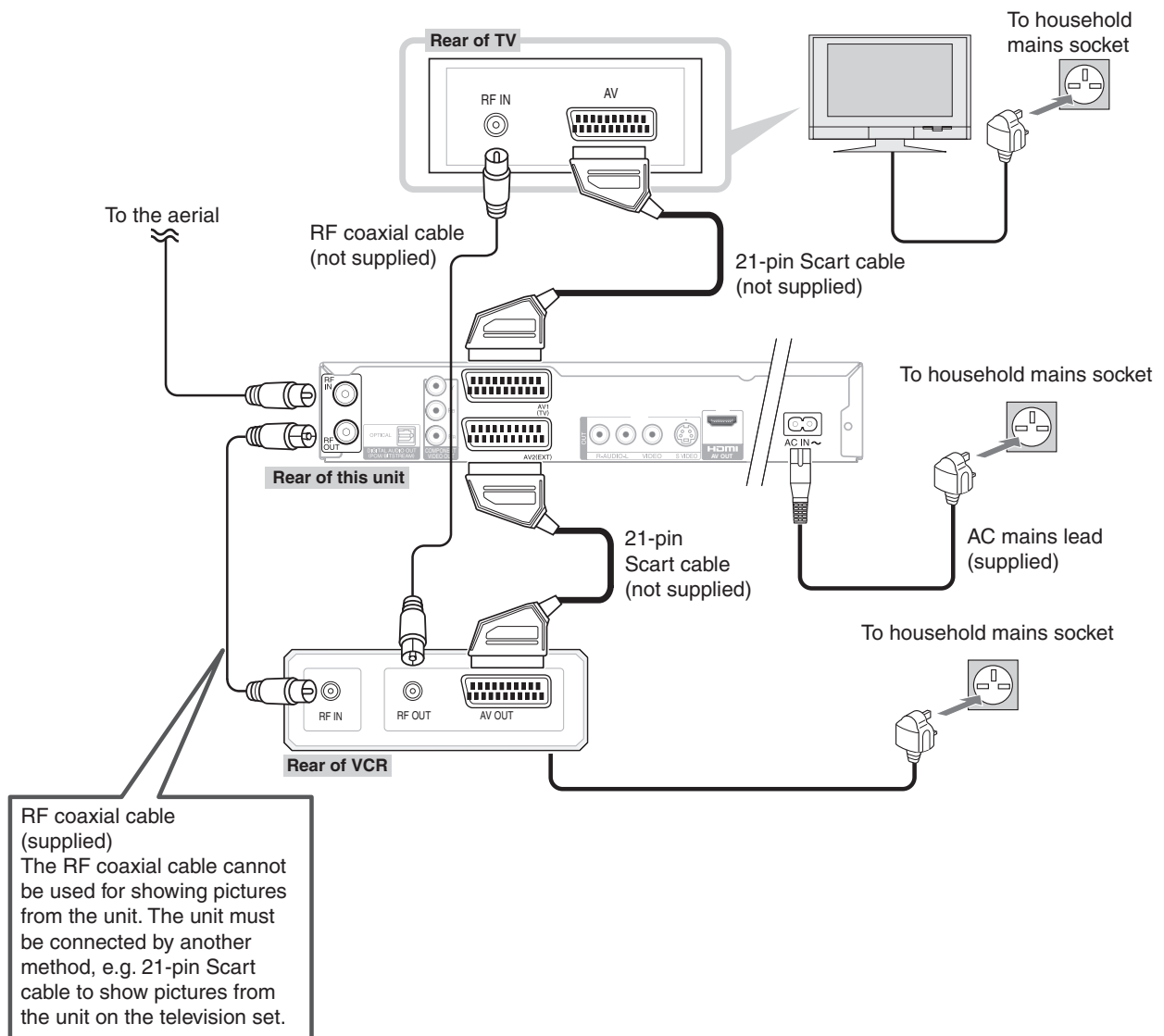

After completing the above connections, proceed to the TV Tuning (→ 11).

To recording from a VCR

Refer to “Recording from an External Device” (→ 26).

- You can connect this unit to a TV using the audio/video (AV) cable, S Video cable or component video cables instead of the 21-pin Scart cable (→ 8, 9, 58).

Using an Audio/Video Cable

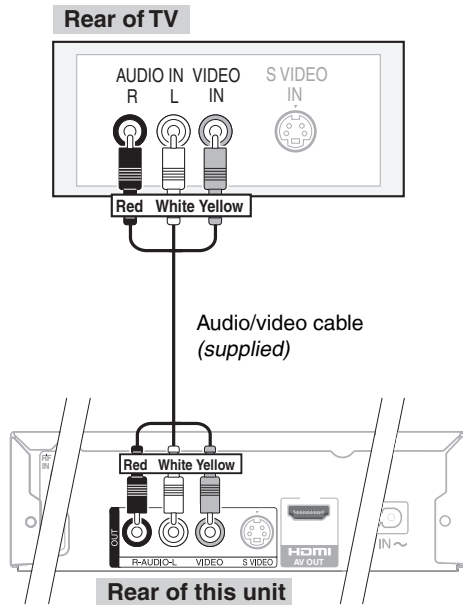

Using an S Video Cable

The S VIDEO OUT terminal achieves a more vivid picture than the VIDEO OUT terminal. (Actual results depend on the television.)

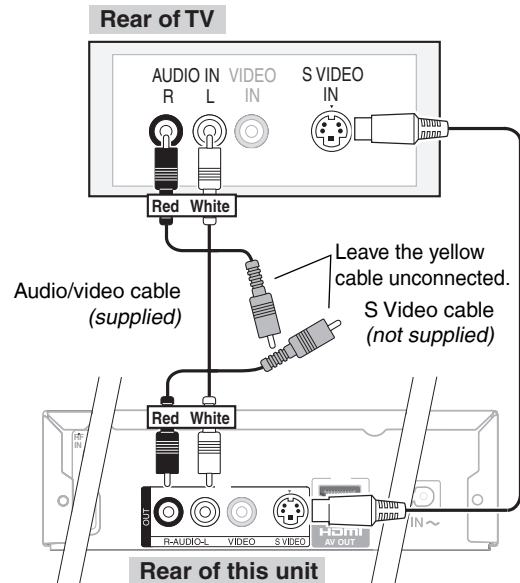

Using Component Video Cables

The COMPONENT VIDEO OUT terminals on this unit can be used for either interlace or progressive output (→ 73) to provide a purer picture than the S VIDEO OUT terminal.

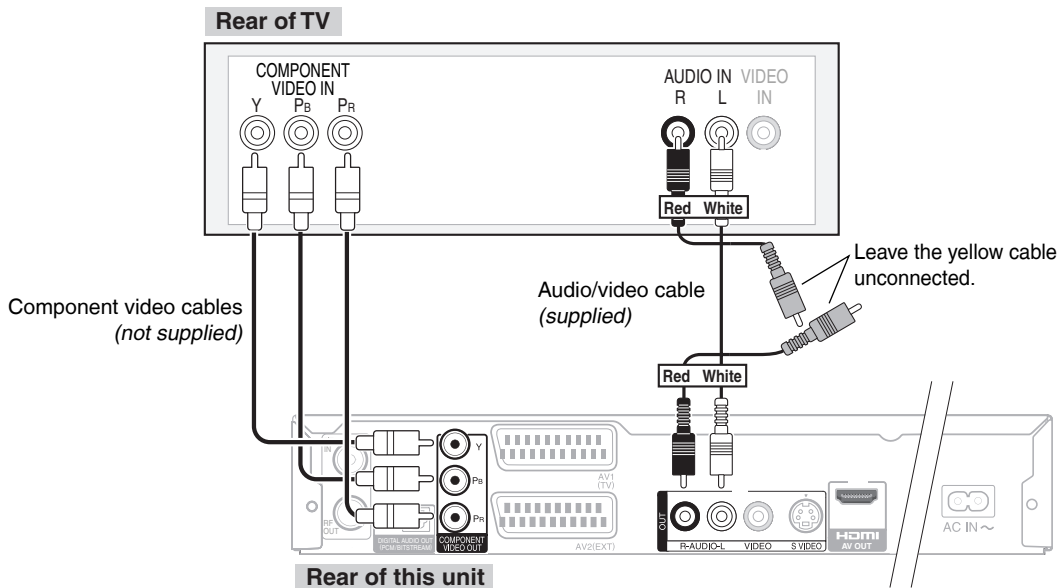

- For progressive output (→ 47)

Notes

If you have a regular television (CRT : cathode ray tube)
Progressive output may cause some flickering, even if it is progressive compatible. Turn off "Progressive" if you are concerned about it (→ 47). This is same for multi-system televisions using PAL mode.

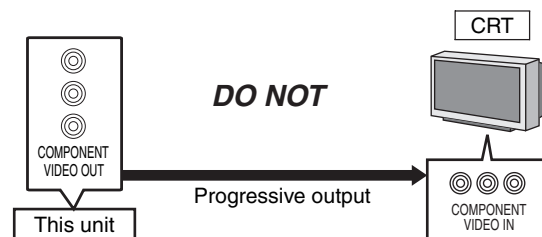

Additional Connections

You can improve sound quality by connecting this unit to an amplifier or system component using the audio cable or the optical digital audio cable.

Using an Audio Cable for Better Sound

Use this connection to play sound through speakers connected to an amplifier or system component.

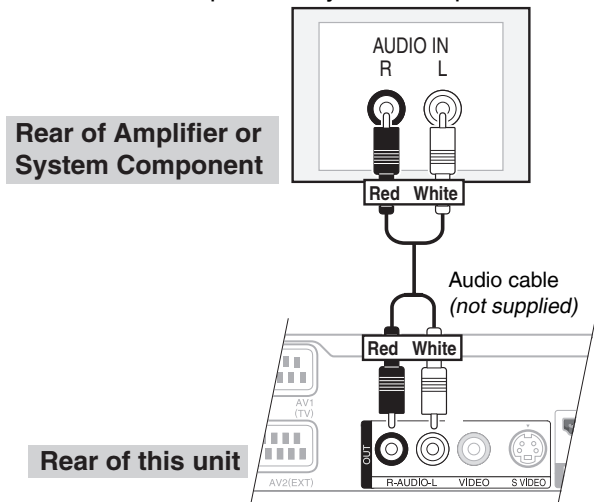

Using an Optical Digital Audio Cable for Better Sound

This method allows you to enjoy multi-channel surround sound on DVD-Video.

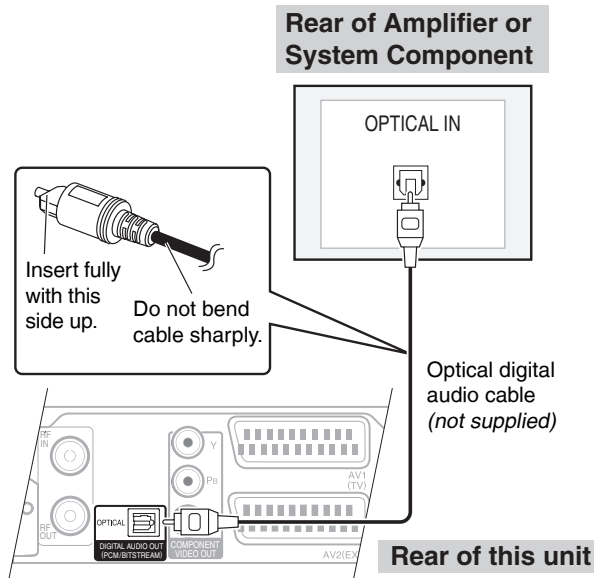

- Connect an amplifier or system component with a built-in decoder displaying these logo marks or MPEG decoder.



- Adjust settings in “Digital Audio Output” (→ 53).

Notes

- When this unit is connected to an amplifier with an optical digital audio cable and connected to a television with an HDMI cable, you can enjoy the highest quality of audio from the disc by setting “Digital Audio Output” to “Optical Only” in the Setup menu (→ 55). In this case audio is only output from the amplifier not the television.
- You cannot use DTS Digital Surround decoders not meant for DVD.
- Before purchasing an optical digital audio cable, check the terminal shape of the equipment to be connected.

Connecting with an HDMI (High Definition Multimedia Interface) Cable

When connected to an HDMI compatible unit, an uncompressed digital audio and video signal is transmitted, enabling you to enjoy high quality, digital video and audio with just one cable. When connecting to an HDMI-compatible HDTV (High Definition Television), the output can be switched to 1080p, 1080i or 720p HD video.

- Please use High Speed HDMI Cables that have the HDMI logo (as shown on the cover).
- When outputting 1080p signal, please use the HDMI cables 5.0 meters or less.

Regarding VIERA Link “HDAVI Control™” function

When connecting with a Panasonic TV (VIERA) or a receiver equipped with the “HDAVI Control” function, linked operations would be possible. [→ 38, Linked Operations with the TV (VIERA Link “HDAVI Control™”/Q Link)]

- It is recommended that you use Panasonic’s HDMI cable. Recommended part number: RP-CDHG10 (1.0 m), RP-CDHG15 (1.5 m), RP-CDHG20 (2.0 m), RP-CDHG30 (3.0 m), RP-CDHG50 (5.0 m), etc.
- Non-HDMI-compliant cables cannot be utilized.

Using an HDMI (High Definition Multimedia Interface) Cable

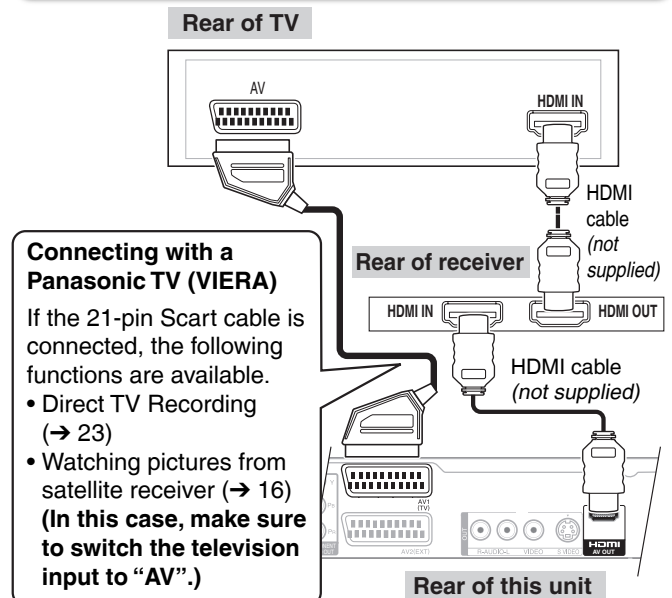

Connecting with a Panasonic TV (VIERA)

If the 21-pin Scart cable is connected, the following functions are available.

- Direct TV Recording (→ 23)
 - Watching pictures from satellite receiver (→ 16)
- (In this case, make sure to switch the television input to “AV”.)**

- Set “Digital Audio Output” to “HDMI and Optical” (→ 55). (The default setting is “HDMI and Optical”).

Notes

- If connecting to equipment that is only audio compatible with 2 channels audio output, audio with 3 channels or more will be down-mixed (→ 72) and output as 2 channels, even if connecting with an HDMI cable (some discs cannot be down-mixed).
- For display units compatible with HDCP (High-Band width Digital Content Protection) that are equipped with a digital DVI input terminal (PC monitors, etc.): Depending on the unit, picture may not display properly or at all when connecting with a DVI/HDMI switching cable (audio cannot be output).

Frequently Asked Questions

Setup		Page
How can I enjoy High Quality Video up-converted to 1080p?	<ul style="list-style-type: none"> Connect the unit to 1080p compatible HDTV using an HDMI cable. Set "HDMI Video Format" in the Setup menu to "1080p". 	10, 55, 60
What equipment is necessary to play multi-channel surround sound?	<ul style="list-style-type: none"> You cannot playback multi-channel sound on this unit without other equipment. You must connect this unit with an HDMI cable or an optical digital audio cable to an amplifier with a built-in (Dolby Digital, DTS or MPEG) decoder. 	60
Can the headphones and speakers be directly connected to the unit?	<ul style="list-style-type: none"> You cannot directly connect to the unit. Connect through the amplifier, TV, etc. 	–
The television has a Scart terminal and component video input terminal. Which terminal should I connect with?	<ul style="list-style-type: none"> If you have a regular television (CRT: cathode ray tube), we recommend using the Scart terminal. You can enjoy high-quality RGB video from this unit by connecting to an RGB compatible television. If you have an LCD/plasma television or LCD projector compatible with progressive scan, connect through the component video terminals for high quality progressive video. If you have a CRT television or a multi-system television using PAL mode that is compatible with progressive scan, we cannot recommend progressive output as some flickering can occur. 	8, 9, 58, 59
Is my TV progressive output compatible?	<ul style="list-style-type: none"> All Panasonic televisions that have 625 (576)/50i · 50p, 525 (480)/60i · 60p input terminals are compatible. Consult the manufacturer if you have another brand of TV. 	–
When are the software updates broadcast ?	<ul style="list-style-type: none"> The unit shows automatically when a software update has been broadcast, and also automatically updates the software if this function has not been switched off in the Setup menu. 	56

Discs		Page
Can I play DVD-Video bought in another country?	<ul style="list-style-type: none"> You cannot play DVD-Video if its region number does not include "2" or "ALL". Refer to the disc's jacket for more information. 	Cover
Can a DVD-Video that does not have a region number be played?	<ul style="list-style-type: none"> Discs either without region encoding or region code 2 will not play on this unit. 	–
What are the constraints regarding DVD-R, DVD-R DL, DVD-RW, +R, +R DL, and +RW compatibility with the unit?	<ul style="list-style-type: none"> The unit records and plays DVD-R, DVD-R DL, DVD-RW (DVD-Video format), +R, +R DL, and +RW, and plays DVD-RW (DVD Video Recording format). The unit also records and plays high speed recording compatible discs. 	13, 14
	<ul style="list-style-type: none"> After recording but before finalising these discs: <ul style="list-style-type: none"> You may not be able to play and record discs on this unit after recording them on other Panasonic products or other manufacturer's equipment. You may not be able to play and record discs on other equipment after recording them on this unit. After finalising the disc, however, you will be able to play it on any DVD-Video compatible player. 	74 –
What are the constraints regarding CD-R and CD-RW compatibility with the unit?	<ul style="list-style-type: none"> This unit plays CD-R/CD-RW discs which have been recorded in one of the following standards: CD-DA, Video CD, SVCD (conforming to IEC62107), MP3, and still pictures (JPEG). Close the session or finalise the disc after recording. This unit can recognize up to 300 folders (groups) and 3000 files (tracks) on a disc with MP3 or still pictures (JPEG). 	14, 15
	<ul style="list-style-type: none"> You cannot write to a CD-R or CD-RW with the unit. 	–

Frequently Asked Questions

Recording		Page
Can I record from a commercially purchased video cassette or DVD?	<ul style="list-style-type: none"> • Most commercially sold video cassettes and DVDs are copy protected; therefore, recording is usually not possible. 	–
Can DVD-R, DVD-R DL, DVD-RW (DVD-Video format), +R, +R DL, and +RW recorded on the unit be played on other equipment?	<ul style="list-style-type: none"> • You can play these discs on compatible equipment such as DVD players after finalising the disc on this unit. • +RW It is not necessary to finalise +RW. To enable play on other DVD players, please use "Create Top Menu" in the DVD Management menu. • In any case, ability to play a disc depends on the condition of the recording, the quality of the disc, and the capability and format constraints of the DVD player. • If you play a DVD-R DL, +R DL or +RW, use compatible equipment. 	49 – –
Can a digital audio signal from the unit be recorded to other equipment?	<ul style="list-style-type: none"> • You can record if using the PCM signal. When recording DVD, change the "Digital Audio Output" settings to the following via the Setup menu: <ul style="list-style-type: none"> – PCM Down Conversion: "On" – Dolby Digital: "PCM" – DTS: "PCM" – MPEG: "PCM" However, only <ul style="list-style-type: none"> – As long as digital recording from the disc is permitted. – As long as the recording equipment is compatible with 48 kHz sampling frequency. • You cannot record MP3 signals. 	53 –

TV Guide		Page
Is it possible to programme a recording, with a start and end time that are different from the TV Guide system?	<ul style="list-style-type: none"> • You can manually change the start and end time of programmes in the Timer Recording menu. But if timings are altered by more than 10 minutes, "Guide Link" will not be able to function. 	29
Can I receive TV Guide system data via a connected satellite receiver or a Set Top Box?	<ul style="list-style-type: none"> • No, only via the built-in tuner. To perform timer recordings with satellite receivers or Set Top Boxes, please use the External Link feature or your unit's manual timer programming. 	25, 27
What happens when I unplug my unit from the household mains socket?	<ul style="list-style-type: none"> • The TV Guide system data will not be updated. If the unit is disconnected from the AC mains for a longer period of time, then the TV Guide data is lost. And if the unit is left unplugged for approximately 60 minutes, the clock and timer recordings that have been set are lost. 	–

DVB-T		Page
Which aerial is suitable for receiving digital terrestrial broadcasts?	<ul style="list-style-type: none"> • Any (terrestrial) roof aerial can be used. However, depending on the area where you live, a new aerial may be necessary. Consult your local TV aerial installer. 	–
Can this unit receive or record High Definition (HD) broadcasts?	<ul style="list-style-type: none"> • No, this unit cannot receive or record High Definition (HD) broadcasts. 	–

Language code list

Enter the code with the numbered buttons.

Abkhazian: 6566	Chinese: 9072	Hausa: 7265	Lithuanian: 7684	Rhaeto-Romance: 8277	Tamil: 8465
Afar: 6565	Corsican: 6779	Hebrew: 7387	Macedonian: 7775	Tatar: 8484	
Afrikaans: 6570	Croatian: 7282	Hindi: 7273	Malagasy: 7771	Romanian: 8279	Telugu: 8469
Albanian: 8381	Czech: 6783	Hungarian: 7285	Malay: 7783	Russian: 8285	Thai: 8472
Amharic: 6577	Danish: 6865	Icelandic: 7383	Malayalam: 7776	Samoan: 8377	Tibetan: 6679
Arabic: 6582	Dutch: 7876	Indonesian: 7378	Maltese: 7784	Sanskrit: 8365	Tigrinya: 8473
Armenian: 7289	English: 6978	Interlingua: 7365	Maori: 7773	Scots Gaelic: 7168	Tonga: 8479
Assamese: 6583	Esperanto: 6979	Irish: 7165	Marathi: 7782	Serbian: 8382	Turkish: 8482
Aymara: 6589	Estonian: 6984	Italian: 7384	Moldavian: 7779	Serbo-Croatian: 8372	Turkmen: 8475
Azerbaijani: 6590	Faroese: 7079	Japanese: 7465	Mongolian: 7778	Shona: 8378	Twi: 8487
Bashkir: 6665	Fiji: 7074	Javanese: 7487	Nauru: 7865	Sindhi: 8368	Ukrainian: 8575
Basque: 6985	Finnish: 7073	Kannada: 7578	Nepali: 7869	Singhalese: 8373	Urdu: 8582
Bengali; Bangla: 6678	French: 7082	Kashmiri: 7583	Norwegian: 7879	Slovak: 8375	Uzbek: 8590
Bhutani: 6890	Frisian: 7089	Kazakh: 7575	Oriya: 7982	Slovenian: 8376	Vietnamese: 8673
Bihari: 6672	Galician: 7176	Kirghiz: 7589	Pashto, Pushto: 8083	Somali: 8379	Volapük: 8679
Breton: 6682	Georgian: 7565	Korean: 7579	Persian: 7065	Spanish: 6983	Welsh: 6789
Bulgarian: 6671	German: 6869	Kurdish: 7585	Polish: 8076	Sundanese: 8385	Wolof: 8779
Burmese: 7789	Greek: 6976	Laotian: 7679	Portuguese: 8084	Swahili: 8387	Xhosa: 8872
Byelorussian: 6669	Greenlandic: 7576	Latin: 7665	Punjabi: 8065	Swedish: 8386	Yiddish: 7473
Cambodian: 7577	Guarani: 7178	Latvian, Lettish: 7686	Quechua: 8185	Tagalog: 8476	Yoruba: 8979
Catalan: 6765	Gujarati: 7185	Lingala: 7678		Tajik: 8471	Zulu: 9085

Messages

On the Unit's Display		Page
H□□, F□□ (“□” stands for a service number.)	<ul style="list-style-type: none"> An error has occurred. The number following “H” or “F” depends on the status of the unit. Check the items below and in the Troubleshooting Guide. If the service number still does not disappear after the check, reset the unit (→ 65, “To restore the unit if it freezes”). If the service numbers fail to clear, note the service numbers and contact a qualified service person. 	–
DVD □ (“□” stands for a number.)	<ul style="list-style-type: none"> The remote control and the main unit are using different codes. Change the code on the remote control. 	65
GUIDE	<ul style="list-style-type: none"> TV Guide data is being downloaded. 	56
HARD ERR**	<ul style="list-style-type: none"> If there is no change after turning the unit on and off, consult the dealer where the unit was purchased. 	–
NoERAS	<ul style="list-style-type: none"> You cannot delete items on this disc. The disc may be damaged. Use a new disc. 	–
NoREAD	<ul style="list-style-type: none"> The disc is dirty or badly scratched. The unit cannot record, play, or edit. The disc may be incompatible or of poor quality. You have used a lens cleaner and it has finished operation. Press [▲ OPEN/ CLOSE] on the main unit to eject the disc. 	13 13, 14 64
NoWRIT	<ul style="list-style-type: none"> You cannot write to this disc. The disc may be damaged. Use a new disc. 	–
FINAL	<ul style="list-style-type: none"> When the screen asking if you want to finalise the disc appears, the message is displayed. 	23
PLEASE WAIT**	<ul style="list-style-type: none"> Displayed when the unit is started. This is not a malfunction. The unit is carrying out its recovery process. You cannot operate the unit while the message is displayed. 	– –
PROG FULL**	<ul style="list-style-type: none"> There are already 16 timer recording programmes. Delete unnecessary timer-recording programmes. 	29
SW-DL	<ul style="list-style-type: none"> The unit is performing a software update. 	56
UNSUPPORT**	<ul style="list-style-type: none"> You have inserted a disc the unit cannot play or record onto. 	13, 14
UNFORMAT**	<ul style="list-style-type: none"> You inserted an unformatted DVD-RAM, DVD-RW, +RW, an unused +R, +R DL or DVD-RW (DVD-Video format) that has been recorded on other equipment. Format the disc to use it. However all the recorded contents on the disc are deleted. 	48
F74	<ul style="list-style-type: none"> The HDMI connection could not be authenticated due to a transfer malfunction. Consult the dealer where the unit was purchased. 	–
F75	<ul style="list-style-type: none"> The HDMI connection could not be authenticated due to an internal data malfunction. Consult the dealer where the unit was purchased. 	–
U59	<ul style="list-style-type: none"> The unit is hot. The unit switches to standby for safety reasons. Wait for about 30 minutes until the message disappears. Select a position with good ventilation when installing the unit. Do not block the cooling fan on the rear of the unit. 	–
U61	<ul style="list-style-type: none"> (When a disc is not inserted) Displays when a malfunction has occurred. This is displayed when the unit is in the recovery process to return to normal operation; it is not broken. Once the display disappears you can use the unit again. 	–
U76	<ul style="list-style-type: none"> HDMI cannot be output because you are connected to a model that does not support copyright protection. 	–
U80 U81 U99	<ul style="list-style-type: none"> The unit fails to operate properly. Press [⏻] on the main unit to switch the unit to standby mode. Press [⏻] on the main unit again to turn the unit on. 	–
U88	<ul style="list-style-type: none"> There was something unusual detected with the disc while recording or playing; there was a power failure or the AC mains lead was disconnected while the unit was on. The unit is carrying out its recovery process. This process restores the unit to normal operation. The unit is not broken. Wait until the message disappears. 	67
X HOLD	<ul style="list-style-type: none"> The Child Lock function is activated. Press and hold [OK] and [RETURN] at the same time until “X HOLD” disappears. 	57

** The message is alternately displayed.

Messages

On the TV		Page
Cannot finish recording completely.	<ul style="list-style-type: none"> The programme was copy-protected. The disc may be full. The maximum number of title has been exceeded. 	– – 22
Cannot play.	<ul style="list-style-type: none"> You inserted an incompatible disc. 	14
Cannot record to the disc.	<ul style="list-style-type: none"> The disc may be dirty or scratched. 	13
Unable to format.		
Please check the disc.		
Cannot record. Disc is full.	<ul style="list-style-type: none"> RAM -RW(V) +RW Create space by erasing unwanted titles. Even if you erase recorded content from the DVD-R, DVD-R DL or +R, +R DL, there is no increase in disc space. Available recording space on a DVD-RW (DVD-Video format) or +RW disc increases when the last title is deleted (space may increase slightly when you delete other titles). Use a new disc. 	20, 41, 48
Cannot record. Maximum number of titles exceeded.		–
No Disc	<ul style="list-style-type: none"> You haven't inserted a disc. Correctly insert a disc that the unit can play. The disc is upside down. If it is a single-sided disc, insert it so the label is facing up. 	13, 14 14
Please set clock.	<ul style="list-style-type: none"> Set the clock. 	12
This is a non-recordable disc.	<ul style="list-style-type: none"> The unit cannot record on the disc you inserted. Insert a DVD-RAM or unfinalised DVD-R, DVD-R DL, DVD-RW (DVD-Video format), +R, +R DL, or +RW disc. The disc may be incompatible or of poor quality. You inserted an unformatted DVD-RAM, DVD-RW, +R, +R DL or +RW disc. Format the disc with the unit. 	13
This disc is not formatted properly. Format it using DVD Management in FUNCTION MENU.		13, 14 48
⊘	<ul style="list-style-type: none"> The operation is prohibited by the unit or disc. 	–

Unit Care

The precision parts in the unit are readily affected by the environment, especially temperature, humidity, and dust. Cigarette smoke also can cause malfunction or breakdown.

- Do not place the unit on amplifiers or equipment that may become hot. The heat can damage the unit.
- Do not place any heavy objects on top of the unit.
- The unit should not be mounted in a vertical position. It's designed to operate in the horizontal position.
- Before moving the unit, ensure the disc tray is empty.
- Failure to do so will risk severely damaging the disc and the unit.

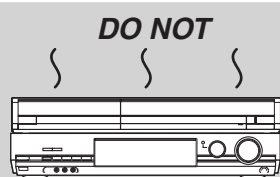

Cautions about condensation

Condensation can cause unreliable playback of recordings. Condensation may form in the following cases,

- The unit is brought from cold surroundings into a well-heated room.
- The unit is suddenly brought from cool surroundings, such as an air-conditioned room or car, to a place which is hot and humid.
- During rainy seasons.

In any of the above-mentioned conditions, do not operate the unit for at least 2 hours. The unit is not equipped with a moisture sensor.

■ Maintenance

To clean the unit

Wipe with a soft, dry cloth.

- Never use alcohol, paint thinner or benzine to clean this unit.
- Before using chemically treated cloth, carefully read the instructions that came with the cloth.

To clean the DVD lens

Dust and dirt may adhere to the unit's lens over time, making it impossible to record or play discs.

Use the **DVD lens cleaner** about once every year, depending on frequency of use and the operating environment.

Carefully read the lens cleaner's instructions before use.

DVD lens cleaner: RP-CL720E

Select a position with good ventilation when installing the unit. Do not block the cooling fan on the rear of the unit.

The manufacturer accepts no responsibility and offers no compensation for loss of recorded or edited material due to a problem with the unit or recordable media, and accepts no responsibility and offers no compensation for any subsequent damage caused by such loss.

Examples of causes of such losses are

- A disc recorded and edited with this unit is played in a DVD Recorder or computer disc drive manufactured by another company.
- A disc used as described above and then played again in this unit.
- A disc recorded and edited with a DVD Recorder or computer disc drive manufactured by another company is played in this unit.

Troubleshooting Guide

When Other Panasonic Products Respond to this Remote Control

Use this function to synchronize the codes for the remote control and the main unit when there are other Panasonic products close to your unit.

With the unit stopped

- 1 Press [FUNCTION MENU].
- 2 Press [▲, ▼] to select "To Others", then press [OK].
- 3 Press [▲, ▼] to select "Setup", then press [OK].
- 4 Press [▲, ▼] to select "Others", then press [▶].
- 5 Press [▲, ▼] to select "Remote Control", then press [OK].
- 6 Press [▲, ▼] to select the code ("DVD 1", "DVD 2" or "DVD 3"), then press [OK].

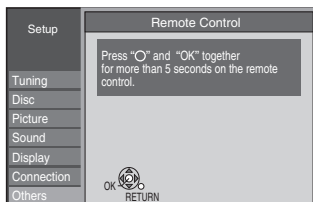

- 7 While pressing and holding [OK], press and hold the numbered button [1], [2] or [3] corresponding to the code set in step 6 for more than 5 seconds to set.
- 8 Press [OK] to complete.

When the following indicator appears on the unit's display



– Change the code on the remote control to match the code displayed for the main unit (→ step 7).



Tips

To return to the previous screen

Press [RETURN].

To exit the screen

Press [EXIT].

To reset this unit

To reset the unit's settings

All the settings except for the ratings level, ratings password, Owner ID and Clock return to the factory preset. The timer recording programmes are also cancelled.

On the main unit

Press and hold [▼ CH] and [CH ▲] for about 5 seconds.

– Refer to Tips of "Auto-Setup Restart" (→ 51) for detail information.

To reset the ratings level settings

With the unit stopped

- 1 Press [▲ OPEN/CLOSE] to open the disc tray.

On the main unit

- 2 Press and hold [● REC] and [▶/x1.3] for about 5 seconds.

To restore the unit if it freezes

On the main unit

Press and hold [⏻/I] for more than 10 seconds.

– The unit is turned off.

Before requesting service, make the following checks. If you are in doubt about some of the check points, or if the solutions indicated in the chart do not solve the problem, consult your dealer for instructions.

The following does not indicate a problem with the unit:

- Regular disc rotating sound.
- Poor reception due to atmospheric conditions.
- Image disturbance during search.
- Periodic interruptions to the reception due to satellite broadcasting breaks.
- Operations are slow to respond in power save mode.
- Operations are not working due to a poor-quality disc. (Try again using a Panasonic disc.)
- The unit freezing due to the activation of one of its safety devices (→ above, To restore the unit if it freezes).
- When the unit is turned on or off, there may be an unexpected sound.

Troubleshooting Guide

General Issues

Power

		Page
No power. The unit does not turn on pressing [⏻ DVD].	• Insert the AC mains lead securely into a known active household mains socket.	8, 9, 58
	• Linked timer recordings with external equipment is in recording standby ("EXT-L" on the unit's display blinks when [⏻ DVD] is pressed). Press [EXT LINK] to cancel the recording standby.	25
The unit switches to standby mode.	• One of the unit's safety devices is activated. Press [⏻/] on the main unit to turn the unit on.	–
The unit is turned off automatically.	• If you connected this unit to an "HDMI Control" compatible TV with an HDMI cable, or connected this unit to a Q Link-compatible TV with a fully wired 21-pin Scart cable, this unit will be automatically set to standby mode when the TV is set to standby mode.	38

General Issues

Displays

		Page
The display is dim.	• Change "FL Display" in the Setup menu.	54
"0:00" is flashing on the unit's display.	• Set the clock.	12
The clock is not correct.	• Under adverse reception conditions, etc., the automatic time correction function may not work. In this case, "Automatic" is automatically turned to "Off". If re-setting the Auto Clock Setting does not work, set the time manually.	12
The displayed time of this unit is different from the actual recording time or MP3 recording time.	• Times shown may disagree with actual times.	–
	• -R -R DL +R +R DL The remaining capacity does not increase even if titles are deleted.	–
	• Available space on a DVD-RW (DVD-Video format) or +RW disc increases when you delete the last title (space may increase slightly when you delete other titles).	–
	• If you record or edit about 200 times or more, the remaining capacity of DVD-R, DVD-R DL, +R, and +R DL is reduced and then recording or editing may be disabled (for the second layer on DVD-R DL and +R DL, this happens after about 60 times).	–
Compared to the actual recorded time, the elapsed time displayed is less. (Only when recording in NTSC)	• The time during searching may not be displayed accurately.	–
	• The displayed recording/play time is converted from the number of frames at 29.97 frames (equal to 0.999 seconds) to one second. There will be a slight difference between the time displayed and the actual elapsed time (e.g., actual one-hour elapsed time may display as approximately 59 minutes 56 seconds). This does not affect the recording.	–
The clock does not display on the unit when switched to standby.	Ensure "Power Save" is set to "Off".	56

General Issues

Operation

		Page
Cannot operate the TV with the unit's remote control.	• Change the manufacturer code on the remote control.	57
	• It may be necessary to set the code on the remote control again after changing the batteries.	65
The remote control doesn't work.	• The remote control code is wrong. Change to the correct code.	65
	• The batteries are depleted. Replace them with new ones.	5
	• Point the remote control at the remote control sensor on the main unit.	5
	• Remove obstacles between the remote control and the main unit.	–
	• Remove dust from the transmission window and the unit's sensor.	–
	• Coloured glass may obstruct the signal reception/transmission.	–
	• Don't place the signal sensor in direct sunlight or in areas that may be subject to sun exposure.	–
	• It may be necessary to set the manufacturer code again after changing the batteries.	57
• The Child Lock function is activated.	57	
The unit is on but cannot be operated.	• Some operations may be prohibited by the disc.	–
	• The unit is warm ("U59" appears on the unit's display). Wait until "U59" disappears.	63
	• One of the unit's safety devices may have been activated. Reset the unit as follows: Press [⏻/] on the main unit to switch to standby mode. If the unit doesn't switch to standby mode, reset the unit (→ 65, "To restore the unit if it freezes").	–
	• The unit cannot be operated while performing an update. "SW-DL" appears on the unit's display while it is updating. Please wait until the "SW-DL" disappears.	56

General Issues

Operation (Continued)

		Page
"U88" is displayed and the disc cannot be ejected.	<ul style="list-style-type: none"> The unit is carrying out the recovery process. The disc may be defective. Do the following to eject the disc. Try another disc. <ol style="list-style-type: none"> Press [⏻] on the main unit to switch to standby mode. If the unit doesn't switch to standby mode, reset the unit (→ 65, "To restore the unit if it freezes"). While the unit is turned off, press and hold [■] and [CH ^] on the main unit at the same time for about 5 seconds. (Ejection may take extra time depending on discs.) 	–
Cannot eject a disc.	<ul style="list-style-type: none"> The unit is recording. The unit may have a problem. Eject the disc as in (2) above. Linked timer recordings with external equipment is in recording standby ("EXT-L" on the unit's display blinks when [⏻ DVD] is pressed). Press [EXT LINK] to cancel the recording standby. If the Child Lock function is activated, above operation does not work. Cancel the Child Lock function. 	– – 25, 57
Startup is slow.	<ul style="list-style-type: none"> Startup takes time in the following situations: <ul style="list-style-type: none"> A disc other than a DVD-RAM is inserted. The clock is not set. Immediately after a power failure or the AC mains lead is connected. When the unit is connected with an HDMI cable. When "Power Save" is set to "Off", startup becomes faster than when "Power Save" is "On". 	– 56

General Issues

VIERA Link

		Page
VIERA Link doesn't work.	<ul style="list-style-type: none"> Check the HDMI cable connection. Check that "HDMI" is displayed on the front display when the power for the main unit is set to On. Make sure that "VIERA Link" is set to "On". Check the "HDAVI Control" settings on the connected device. Some functions may not work depending on the version of "HDAVI Control" of the connected equipment. This unit supports "HDAVI Control 3" functions. If the connection for the equipment connected with an HDMI cable was changed, or if there was a power failure or the plug was removed from the household mains socket, "HDAVI Control" may not work. In this case, perform the following operations. <ol style="list-style-type: none"> When the HDMI cable is connected to all equipment with the power on, turn the TV (VIERA) on again. Change the TV (VIERA) settings for the "HDAVI Control" function to off, and then set to on again. (For more information, see the VIERA operating instructions.) Switch the VIERA input to HDMI connection with this unit, and after this unit's screen is displayed, check that "HDAVI Control" is working. 	– 55 – – –
The control panel does not appear.	<ul style="list-style-type: none"> The control panel is only displayed when connected to a TV with "HDAVI Control 2" or "HDAVI Control 3" function. 	39

General Issues

DVB-T

		Page
Digital broadcasts cannot be received.	<ul style="list-style-type: none"> Check the connections. Digital broadcast may not have started in your region yet. The aerial may not be pointing in the direction of the TV station, or the direction of the aerial may have changed due to strong winds or vibration. If problem persists consult your local TV aerial installer. Perform "Auto-Setup Restart" in the Setup menu. 	8, 9, 58 – – 51
TV reception worsens after connecting the unit.	<ul style="list-style-type: none"> This can occur because the signals are being divided between the unit and other equipment. It can be solved by using a signal booster, available from electronics retailers. 	–
After DVB Auto-Setup only some or no DVB channels are found.	<ul style="list-style-type: none"> Check to ensure your area is covered by DVB transmissions. Check that the aerial and antenna cable are designed for DVB. Use the supplied RF coaxial cable shown in STEP 2, Basic Connection. If you live within 5-10 km of DVB transmission towers, a combined VHF/UHF aerial should be adequate. Outside this area, separate VHF and UHF aerials provide superior reception performance. Perform "Auto-Setup Restart" in the Setup menu. 	– 8, 9 51

Troubleshooting Guide

General Issues

DVB-T (Continued)

		Page
Picture regularly breaks up on some channels, "No Signal" message is displayed.	• Check "Signal Condition". If "Signal Quality" or "Signal Strength" are displayed in red or constantly changing, check aerial. If problem persists consult your local TV aerial installer.	51
	• Check that the aerial and antenna cable are designed for DVB. Use the supplied RF coaxial cable shown in STEP 2, Basic Connection.	8, 9
	• Interference (known as impulse noise) from household appliances such as light switches, fridges, etc. may cause picture break up and/or audio distortion. Use a high quality quad shielded coaxial cable fly lead between this unit and antenna wall socket to minimise impulse noise pickup. If problem persists consult your local TV aerial installer.	–
	• When "No Signal" message is displayed, check aerial connection.	–
	• Adjust the aerial reception with "DVB Manual Tuning". • Perform "Auto-Setup Restart" in the Setup menu.	51 51
Picture very infrequently breaks up on some or all channels.	• Electrical atmospheric interference caused by local or distant lightning storms or heavy rain with wind in "leafy" locations may cause pictures to break up and audio to mute or distort momentarily.	–
	• Impulse noise interference from an infrequently used electrical appliance, or a passing vehicle or lawn mower with a "noisy" ignition system.	–
Unusual station sorting.	• The station sorting of this unit is pre-defined. Use profiles to sort the stations as you want them.	50
The digital channel information does not appear.	• Select the length of time (3-10 sec.) in the "On-Screen Messages" in the Setup menu.	54
	• The digital channel information will not appear during playback or recording.	–
	• Perform "Auto-Setup Restart" in the Setup menu.	51
No Digital TEXT.	• When subtitle is on or additional information in the digital channel information is displayed, Digital TEXT does not work. • Perform "Auto-Setup Restart" in the Setup menu.	– 51
After the Auto-Setup, there aren't any stations in the station list although found stations were displayed during Auto-Setup.	• "Shipping Condition" was performed or the unit was in the delivery status. The Auto-Setup was then started and interrupted. Do an Auto-Setup again and let it continue right through to the end. The data is only saved after this has been completed.	–
The Signal Strength is over 100 % (> 10).	• Reduce the signal amplification at your aerial.	51
Poor picture in spite of good signal quality.	• Overmodulation makes the signal strength display go to red. Readjust the picture with your room aerial until the picture quality improves.	–

General Issues

TV Guide

		Page
The TV Guide System does not receive any data.	• Check whether the clock is properly set.	12
	• If signal quality is bad (ghost images or limited reception), the TV Guide system may not be able to receive any data.	–
	• Perform "Auto-Setup Restart" in the Setup menu.	51
"No Data" is displayed for some or all stations.	• Some stations are not supported by the TV Guide system.	–
	• Programme the Timer recording manually.	27
	• Perform "Auto-Setup Restart" in the Setup menu.	51
The TV Guide information is not displayed properly.	• There was a programme change or TV Guide information from a broadcast station was possibly not correctly transmitted. Check the current programme, e.g. on the Web site for the TV Guide system provider or station provider.	–
The TV Guide data is not updated.	• The unit must be in standby mode in order to update the data. If the unit is in EXT LINK mode ("EXT-L" lights on the unit's display), then the data update may also not work.	–
	• Make sure that the time is set correctly.	12
	• Check whether "Off" is set under "TV Guide Download in Standby" and change the setting in System Update in the Setup menu.	56

Playback Issues

Sound

		Page
Cannot switch audio.	• You cannot switch the audio in the following cases.	
	– When a DVD-R, DVD-R DL, DVD-RW (DVD-Video format), +R, +R DL or +RW disc is in the disc tray	–
	– When the recording mode is XP and "Audio Mode for XP Recording" is set to "LPCM"	53
	• When recording a digital broadcast with multiple audio channels, this unit will record only the audio channel selected in "DVB Multi Audio" in the on-screen display. The audio channel cannot be switched during playback.	47
	• You have used a digital connection. Set "Dolby Digital" to "PCM" or connect using audio cables (analogue connection).	53, 60
• There are discs whose audio cannot be changed due to how the disc was created.	–	

Playback Issues

Sound (Continued)

		Page
No sound. Low volume. Distorted sound. Cannot hear the desired audio type.	• Check the connections and the “Digital Audio Output” settings. Check the input mode on the amplifier if you have connected one.	53, 60
	• Check if TV is muted.	–
	• Check if amplifier is muted.	–
	• Sound is not output while fast-forwarding during chasing playback and simultaneous record and playback.	–
	• Set “V.S.S.” in the Sound menu to “Off” in the following cases: –When using discs that do not have surround sound effects, such as Karaoke discs –When playing bilingual broadcast programmes	47
	• The sound effects will not work when the bitstream signal is output from the HDMI AV OUT terminal or the DIGITAL AUDIO OUT terminal.	–
	• Audio may not be heard when more than 4 devices are connected with HDMI cables. Reduce the number of connected devices.	–
	• To output audio from a device connected with an HDMI cable, set “Digital Audio Output” to “HDMI and Optical” in the Setup menu.	55
• Depending on the connected equipment, the sound may be distorted if this unit is connected with an HDMI cable.	–	

Playback Issues

Picture

		Page
The images from this unit do not appear on the TV. Picture is distorted.	• Make sure the recorder is connected to an appropriate AV input of the TV.	8, 9, 10, 58, 59, 60
	• Make sure the TV’s input setting (e.g., AV 1) is correct.	–
	• The TV isn’t compatible with progressive signals. Press and hold [■] and [▶/x1.3] on the main unit for about 5 seconds. The setting will change to interlace.	–
	• The TV isn’t compatible with RGB signals. Set “AV1 Output” in the Setup menu to “Video (with component)” or “S Video (with component)”.	55
	• The unit’s “TV System” setting differs from the TV system used by the disc now playing. While stopped, keep pressing [■] and [▲ OPEN/CLOSE] on the main unit for 5 or more seconds. The system switches from PAL to NTSC or vice versa.	55
	• When this unit is connected with an HDMI cable, use a disc that matches with this unit’s TV system.	–
• Picture may not be seen when more than 4 devices are connected with HDMI cables. Reduce the number of connected devices.	–	
Picture does not appear during timer recording.	• Timer recordings work regardless of whether the unit is on or off. To confirm the timer recording is going to work properly, turn the unit on.	–
The 4:3 aspect ratio picture expands left and right. Screen size is wrong.	• Use the TV to change the aspect. If your TV does not have that function, set “Progressive” in the Picture menu to “Off”.	47
	• If you connect an HDMI cable, set “Aspect for 4:3 Video” in the Setup menu to “16:9”. • Check the settings for “TV Aspect” in the Setup menu. It may be possible to adjust the display mode on the TV. Refer to your television’s operating instructions.	55 54
The recorded title is stretched vertically.	• 16:9 aspect programmes are recorded in 4:3 aspect in the following cases. – [R] [R DL] [RW(V)] If you recorded using “EP” or “FR (recordings 5 hours or longer)” recording mode – If you recorded to a +R, +R DL or +RW It may be possible to adjust the display mode on the TV. Refer to your television’s operating instructions.	–
There is a lot of after-images when playing video.	• Set “Playback NR” in the Picture menu to “Off”.	47
When playing DVD-Video using progressive output, one part of the picture momentarily appears to be doubled up.	• Set “Progressive” in the Picture menu to “Off”. This problem is caused by the editing method or material used on DVD-Video, but should be corrected if you use interlaced output.	47
There is no apparent change in picture quality when making adjustments in the Picture menu using the on-screen display.	• The effect cannot be seen with certain types of video.	–
Cannot see the beginning of the title played.	• (If connecting to a TV that supports VIERA Link with an HDMI cable) When [▶ PLAY] is pressed on this unit’s remote control, you may not be able to see the beginning of the title played until the picture is displayed on the TV. Using [◀◀] or [◀◀], return to the beginning of the title.	–
The picture is distorted during play, or video will not play correctly.	• You may be playing a TV programme recorded with poor reception or unfavourable weather conditions.	–
	• The picture may be distorted or a black screen may appear briefly between recorded titles in the following situations: –between titles recorded with different recording modes. –between scenes recorded with different aspect ratios. –between scenes recorded with different resolutions.	–
	–between playlist chapters.	–

Troubleshooting Guide

Playback Issues

Operation

		Page
The image from this unit does not appear on the TV.	<ul style="list-style-type: none"> TV is not compatible with RGB signal. Set "AV1 Output" in the Setup menu to "Video (with component)" or "S Video (with component)". 	55
Play fails to start even when [▶ PLAY] is pressed. Play starts but then stops immediately.	<ul style="list-style-type: none"> Insert the disc correctly with the label facing up. The disc is dirty. You tried to play a blank disc or a disc that is unplayable on the unit. You tried to play a +RW that needs to be finalised on the equipment used for recording. When recording to DVD-RAM using EP (8Hours) mode, play may not be possible on DVD players that are compatible with DVD-RAM. In this case use EP (6Hours) mode. You cannot play discs during DV automatic recording. 	14 13 13, 14, 15 – 52 –
Audio and video momentarily pause.	<ul style="list-style-type: none"> This occurs between playlist chapters. This occurs as scenes change during Quick View (Play x1.3). -R DL +R DL When playing a title recorded on both layers, the unit automatically switches between layers and plays the title in the same way as a normal programme. However, video and audio may momentarily cut out when the unit is switching layers. 	– – 21
DVD-Video is not played.	<ul style="list-style-type: none"> Ensure the DVD-Video region number for the disc is correct, and the disc is not defective. You have set a ratings level to limit DVD-Video play. Change this setting. 	Cover, 14 52
Alternative soundtrack and subtitles cannot be selected.	<ul style="list-style-type: none"> The languages are not recorded on the disc. You may have to use the disc's own menus to select languages and audio tracks. 	– 17
No subtitles.	<ul style="list-style-type: none"> Subtitles are not recorded on the disc. Set "Subtitle" in the Disc menu to "On". 	– 46
Angle cannot be changed.	<ul style="list-style-type: none"> This function depends on software availability. Angles can only be changed during scenes where different angles are recorded. 	–
You have forgotten your ratings password.	<ul style="list-style-type: none"> With the tray open, press and hold [● REC] and [▶/x1.3] on the main unit simultaneously for about 5 or more seconds. 	65
Quick View (Play x1.3) does not work.	<ul style="list-style-type: none"> This does not work when audio is other than Dolby Digital. This does not work while recording in XP or FR mode. 	– –
The resume play function does not work.	<ul style="list-style-type: none"> Memorized positions are cancelled when the tray is opened. 	–
The Video CD picture does not display properly.	<ul style="list-style-type: none"> When connecting to Multi-system TV, select "NTSC" in "TV System" in the Setup menu. When connecting to PAL TV, the lower part of the picture cannot be displayed correctly during search. 	55 –
Time Slip, Manual Skip, etc. do not work.	<ul style="list-style-type: none"> These functions do not work with finalised discs. Time Slip does not work when the unit's "TV System" settings are different from the title recorded on the disc. 	– 55
Cannot see the beginning of the title played.	<ul style="list-style-type: none"> (If connecting to a TV that supports VIERA Link with an HDMI cable) When [▶ PLAY] is pressed on this unit's remote control, you may not be able to see the beginning of the title played until the picture is displayed on the TV. Using [◀◀] or [◀◀], return to the beginning of the title. 	–

Recording Issues

Recording / Timer recording / External input

		Page
Cannot record.	<ul style="list-style-type: none"> You haven't inserted a disc or the disc you inserted cannot be recorded on. Insert a disc the unit can record onto. RAM -RW(V) +R +R DL +RW The disc is unformatted. Format the disc. The write-protect tab on the cartridge is set to "PROTECT" or the disc is protected with the "DVD Management" settings. Some programmes have limitations on the number of times they can be recorded (CPRM). The disc is full or nearly full. Delete unneeded titles (RAM -RW(V) +RW) or use another disc. You cannot record on finalised DVD-R, DVD-R DL, DVD-RW (DVD-Video format), +R, or +R DL discs. However, you can record again if you format DVD-RW. If you repeatedly insert discs or turn the unit on and off about 50 times or more, the recording or editing of DVD-R, DVD-R DL, DVD-RW (DVD-Video format), +R, +R DL, and +RW discs may be disabled. DVD-R, DVD-R DL, DVD-RW (DVD-Video format), +R, +R DL, or +RW discs recorded on the unit may not be recordable on other Panasonic DVD Recorders. The broadcast you are trying to record is copy-protected. This unit cannot record NTSC signals to discs that already have PAL signal recordings. Play of discs recorded with both PAL and NTSC on another unit is not guaranteed. 	13 48 48 13, 21, 72 20, 41, 48 – – – – 55
Digital broadcasts cannot be recorded.	<ul style="list-style-type: none"> Some digital broadcasts are copyright protected with a "One time only recording" security feature. This type of programme can only be recorded onto a CPRM compatible DVD-RAM. 	13, 21, 72

Recording Issues Recording / Timer recording / External input (Continued)

		Page
Timer recording does not work properly.	• The timer programme is incorrect or different timer programme times overlap. Correct the programme.	29
	• The programme is not in timer recording standby. (“⌚” in the timer recording list is not on.) 1 Press [PROG/CHECK]. 2 Press [▲, ▼] to select the programme and press the “Red” button.	29
	• The clock is not correct. Set the clock.	12
	• The programme information in the TV Guide system may not be correct. It is recommended to modify the start and end times to allow a margin of a few minutes.	19
Timer recording does not stop even when [■ STOP] is pressed.	• When using the linked timer recording with external equipment, press [EXT LINK]. (“EXT-L” on the unit’s display disappears.)	25
The timer programme remains even after recording finishes.	• The timer programme remains if set to daily or weekly.	27, 28, 29
Part or all of a recorded title has been lost.	• If the power shuts down or the AC mains lead is disconnected from the household mains socket while recording or editing, the title may be lost or the disc may become unusable. We cannot offer any guarantee regarding lost titles or discs. You will have to format the disc (RAM -RW(V) +RW) or use a new disc.	–
Stripe-shaped black noise is recorded.	• An external playback device is interfering with the TV because the device is too close to the TV. Move the device away from the TV.	–
The programme name and the recorded title do not match.	• There was a programme change after timer recording was set but the recorded title still has the old programme name.	–
An unusually loud sound is coming from the rotating DVD-R, etc.	• When recording to a DVD-R, DVD-R DL, DVD-RW (DVD-Video format), +R, +R DL and +RW the sound of the disc rotating may be louder than normal, however, this is not a problem.	–
Cannot record video or sound from the external device.	• The external device is not correctly connected.	9, 26, 58
	• The proper external input channel (AV2, AV3 or DV) is not selected. Press [INPUT SELECT] to change.	–
The DV auto recording function does not work.	• If images cannot be recorded or if the recording is aborted, check the connections and the DV equipment settings.	26
	• You cannot start recording until the images from the DV equipment appear on the television.	–
	• Recording may not be performed as desired if the time codes on the tape in the DV equipment are not successive.	–
	• Depending on the equipment, the DV automatic recording may not operate properly.	–
	• You can only record audio/video images on a DV tape.	–

Editing Issues DVD

		Page
Cannot format.	• The disc is dirty. Wipe with a damp cloth and then wipe dry.	13
	• Disc may be defective or of poor quality.	–
	• You tried formatting a disc that is not compatible with the unit.	48
Cannot create chapters.	• The unit writes the chapter division information to the disc when you turn it off or remove the disc. The information is not written if there is an interruption in the power.	–
Cannot mark the start point or the end point during “Partial Delete” operation.	• These operations are not possible with still pictures.	–
	• You cannot set points if they are too close to each other. You cannot set an end point before a start point.	–
Cannot delete chapters.	• RAM When the chapter is too short to delete, use “Combine Chapters” to make the chapter longer.	43
The available recording time doesn’t increase even after deleting titles on the disc.	• Available space on DVD-R, DVD-R DL, +R, or +R DL does not increase even after deleting previous titles.	–
	• Available space on DVD-RW (DVD-Video format) or +RW increases when you delete the last title.	–
Cannot create a playlist.	• You cannot select all the chapters in a title at once as the source of playlist editing if the title also includes still pictures. Select them individually.	–

Glossary

Bitstream

This is a signal compressed and converted into digital form. It is converted back to a multi-channel audio signal, e.g., 5.1-channel, by a decoder.

CPRM (Content Protection for Recordable Media)

CPRM is technology used to protect broadcasts that are allowed to be recorded only once. Such broadcasts can be recorded only with CPRM-compatible recorders and discs.

Decoder

A decoder restores the coded audio signals on DVDs to normal. This is called decoding.

Deep Colour

This unit incorporates HDMI™ (V.1.3 with Deep Colour) technology that can reproduce greater colour gradation (4096 steps) when connected to a compatible TV.

You can enjoy exceptionally rich, natural-looking colours, with smooth, detailed gradation and minimal colour banding.

[A lower colour gradation (256 steps), without deep colour, will be reproduced if connected to a TV which does not support deep colour. The unit will automatically set appropriate output to suit the connected TV.]

Dolby Digital

This is a method of coding digital signals developed by Dolby Laboratories. Apart from stereo (2-channel) audio, these signals can also be multi-channel audio. A large amount of audio information can be recorded on one disc using this method.

When recording on this unit Dolby Digital (2 channel) is the default audio.

Down-mixing

This is the process of remixing the multi-channel audio found on some discs into two channels. It is useful when you want to listen to the 5.1-channel audio recorded on DVDs through your TV's speakers. Some discs prohibit down-mixing. If this is the case, this unit can only output the front two channels.

DTS (Digital Theater Systems)

This surround system is used in many movie theaters. There is good separation between the channels, so realistic sound effects are possible.

Dynamic range

Dynamic range is the difference between the lowest level of sound that can be heard above the noise of the equipment and the highest level of sound before distortion occurs. Dynamic range compression means reducing the gap between the loudest and softest sounds. This means you can hear dialogue clearly at low volume.

Film and Video

DVD-Videos are recorded using either film or video. The unit can determine which type has been used, then uses the most suitable method of progressive output.

Film: Recorded at 25 frames per second (PAL discs) or 24 frames per second (NTSC discs). (NTSC discs recorded at 30 frames per second as well.)

Generally appropriate for motion picture films.

Video: Recorded at 25 frames/50 fields per second (PAL discs) or 30 frames/60 fields per second (NTSC discs). Generally appropriate for TV drama programmes or animation.

Finalise

A process that makes play of a recorded CD-R, CD-RW, DVD-R, etc. possible on equipment that can play such media. You can finalise DVD-R, DVD-R DL, DVD-RW (DVD-Video format), +R, and +R DL on the unit. After finalising, the disc becomes play-only and you can no longer record or edit. However, finalised DVD-RW can be formatted to become recordable.

Formatting

Formatting is the process of making media such as DVD-RAM recordable on recording equipment. You can format DVD-RAM, DVD-RW (only as DVD-Video format) and +RW or unused +R and +R DL on this unit. Formatting irrevocably erases all contents.

Frame and Field

Frame refers to the single images that constitute the video you see on your TV. Each frame consists of 2 fields.

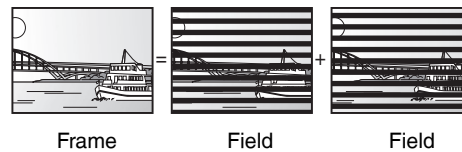

- A frame still shows 2 fields, so there may be some blurring between them, but picture quality is generally better.
- A field still shows less picture information so it may be rougher, but there is no blurring.

HDMI (High-Definition Multimedia Interface)

Unlike conventional connections, it transmits uncompressed digital video and audio signals on a single cable. This unit supports high-definition video output [720p (750p), 1080i (1125i), and 1080p (1125p)] from HDMI AV OUT terminal. To enjoy high-definition video a high definition compatible television is required.

JPEG (Joint Photographic Experts Group)

This is a system used for compressing/decoding colour still pictures. If you select JPEG as the storage system on digital cameras, etc., the data will be compressed to 1/10-1/100 of its original size. The benefit of JPEG is less deterioration in picture quality considering the degree of compression.

LPCM (Linear PCM)

These are uncompressed digital signals, similar to those found on CDs.

MPEG2 (Moving Picture Experts Group)

A standard for efficiently compressing and expanding colour video. MPEG2 is a compression standard used for DVD and satellite based digital broadcasting. This unit records programmes using MPEG2.

MP3 (MPEG Audio Layer 3)

An audio compression method that compresses audio to approximately 1/10 of its size without any significant loss of audio quality.

Pan & Scan/Letterbox

In general, DVD-Video are produced with the intention that they will be viewed on a widescreen TV (16:9 aspect ratio), so images often don't fit regular TVs (4:3 aspect ratio). 2 styles of picture, "Pan & Scan" and "Letterbox", deal with this problem.

Pan & Scan: The sides are cut off so the picture fills the screen.



Letterbox: Black bands appear at the top and bottom of the picture so the picture itself appears in an aspect ratio of 16:9.



Playback control (PBC)

If a Video CD has playback control, you can select scenes and information with menus.

(The unit is compatible with version 2.0 and 1.1.)

Safety precautions

Progressive/Interlace

The PAL video signal standard has 625 (or 576) interlaced (i) scan lines, whereas progressive scanning, called 625p (or 576p), uses twice the number of scan lines. For the NTSC standard, these are called 525i (or 480i) and 525p (or 480p) respectively.

Using progressive output, you can enjoy the high-resolution video recorded on media such as DVD-Video.

Your television must be compatible to enjoy progressive video. Panasonic televisions with 625 (576)/50i · 50p, 525 (480)/60i · 60p input terminals are progressive compatible.

Protection

You can prevent accidental erasure by setting writing protection or erasure protection.

RGB

This refers to the three primary colours of light, red (R), green (G), and blue (B) and also the method of producing video that uses them. By dividing the video signal into the three colours for transmission, noise is reduced for even higher quality images.

Sampling frequency

Sampling is the process of converting the heights of sound wave (analogue signal) samples taken at set periods into digits (digital encoding). Sampling frequency is the number of samples taken per second, so larger numbers mean more faithful reproduction of the original sound.

Signal Quality

This is the guide for checking the aerial direction. The numbered values displayed do not indicate the strength of the signal, but the quality of the signal (the signal to noise ratio, or "S/N"). The channels you can receive are affected by weather conditions, seasons, time (day/night), region, length of the cable that is connected to the aerial, etc.

Thumbnail

This refers to a miniature representation of a picture used to display multiple pictures in the form of a matrix.

1080i

In one high-definition image, 1080 (1125) alternating scan lines pass every 1/50th of a second to create an interlace image. Because 1080i (1125i) more than doubles current television broadcasts of 480i (525i), the detail is much clearer and creates a more realistic and rich image.

1080p

In one high-definition image, 1080 (1125) scan lines pass at the same time every 1/50th of a second to create a progressive image. Since progressive video does not alternate scan lines like interface, there is a minimal amount of screen flicker.

720p

In one high-definition image, 720 (750) scan lines pass at the same time every 1/50th of a second to create a progressive image. Since progressive video does not alternate scan lines like interlace, there is a minimal amount of screen flicker.

Placement

Set the unit up on an even surface away from direct sunlight, high temperatures, high humidity, and excessive vibration. These conditions can damage the cabinet and other components, thereby shortening the unit's service life.

Do not place heavy items on the unit.

Voltage

Do not use high voltage power sources. This can overload the unit and cause a fire.

Do not use a DC power source. Check the source carefully when setting the unit up on a ship or other place where DC is used.

AC mains lead protection

Ensure the AC mains lead is connected correctly and not damaged. Poor connection and lead damage can cause fire or electric shock.

Do not pull, bend, or place heavy items on the lead.

Grasp the plug firmly when unplugging the lead. Pulling the AC mains lead can cause electric shock.

Do not handle the plug with wet hands. This can cause electric shock.

Foreign matter

Do not let metal objects fall inside the unit. This can cause electric shock or malfunction.

Do not let liquids get into the unit. This can cause electric shock or malfunction. If this occurs, immediately disconnect the unit from the AC mains supply and contact your dealer.

Do not spray insecticides onto or into the unit. They contain flammable gases which can ignite if sprayed into the unit.

Service

Do not attempt to repair this unit by yourself. If sound is interrupted, indicators fail to light, smoke appears, or any other problem that is not covered in these instructions occurs, disconnect the AC mains lead and contact your dealer or an authorized service centre. Electric shock or damage to the unit can occur if the unit is repaired, disassembled or reconstructed by unqualified persons.

Extend operating life by disconnecting the unit from the AC mains if it is not to be used for a long time.

Manufactured under license from Dolby Laboratories. Dolby and the double-D symbol are trademarks of Dolby Laboratories.

"DTS" is a registered trademark of DTS, Inc. and "DTS 2.0+Digital Out" is a trademark of DTS, Inc.

U.S. Patent Nos. 6,836,549; 6,381,747; 7,050,698; 6,516,132; and 5,583,936.

This product incorporates copyright protection technology that is protected by U.S. patents and other intellectual property rights. Use of this copyright protection technology must be authorized by Macrovision, and is intended for home and other limited viewing uses only unless otherwise authorized by Macrovision. Reverse engineering or disassembly is prohibited.

HDMI, the HDMI logo and High-Definition Multimedia Interface are trademarks or registered trademarks of HDMI Licensing LLC.

HDAVI Control™ is a trademark of Matsushita Electric Industrial Co., Ltd.

Specifications

Power supply: AC 220 V to 240 V, 50 Hz
Power consumption: Approx. 25 W
Standby mode: (Power Save mode): Approx. 2 W
(Quick Start mode): Approx. 15 W

Recordable discs:

DVD-RAM: 2X SPEED (Ver. 2.0)
2-3X SPEED (Ver. 2.1)
2-5X SPEED (Ver. 2.2)
DVD-R (SL): 1X SPEED (Ver. 2.0)
1-4X SPEED (Ver. 2.0)
1-8X SPEED (Ver. 2.0)
1-16X SPEED (Ver. 2.1)
DVD-R (DL): 2-4X SPEED (Ver. 3.0)
2-8X SPEED (Ver. 3.0)
DVD-RW: 1X SPEED (Ver. 1.1)
1-2X SPEED (Ver. 1.1)
2-4X SPEED (Ver. 1.2)
2-6X SPEED (Ver. 1.2)
+R (SL): 2.4X SPEED (Ver. 1.0)
2.4-4X SPEED (Ver. 1.1)
2.4-8X SPEED (Ver. 1.2)
2.4-16X SPEED (Ver. 1.3)
+R (DL): 2.4X SPEED (Ver. 1.0)
2.4-8X SPEED (Ver. 1.1)
+RW: 2.4X SPEED (Ver. 1.1)
2.4-4X SPEED (Ver. 1.2)

Recording system:

DVD-RAM: DVD Video Recording format
DVD-R: DVD-Video format
DVD-R DL (Dual Layer):
DVD-Video format
DVD-RW: DVD-Video format
+R
+R DL (Double Layer)
+RW

Recording time:

Max. 8 hours (using 4.7 GB disc)
XP: Approx. 1 hour SP: Approx. 2 hours
LP: Approx. 4 hours EP: Approx. 6 hours or 8 hours

Playable discs:

DVD-RAM: DVD Video Recording format
DVD-R: DVD-Video format, MP3^{*1}, JPEG^{*1}
DVD-R DL (Dual Layer):
DVD-Video format, MP3^{*1}, JPEG^{*1}
DVD-RW: DVD Video Recording format, DVD-Video format
+R
+R DL (Double Layer)
+RW
DVD-Video, CD-Audio (CD-DA)
Video CD, SVCD^{*2}
CD-R/CD-RW (CD-DA^{*1}, Video CD^{*1}, SVCD^{*1*2}, MP3^{*1},
JPEG^{*1})
※1 Finalising is necessary for compatible playback.
※2 Conforming to IEC62107
This unit is not compatible with "Chaoji VCD" available
on the market including CVD, DVCD and SVCD that do
not conform to IEC62107.

Optical pick-up:

System with 1 lens, 2 integration units
(662 nm wavelength for DVDs, 780 nm wavelength for CDs)

LASER Specification:

Class 1 LASER Product
Wave Length: 780 nm (CDs)
662 nm (DVDs)
Laser Power: No hazardous radiation is emitted
with the safety protection

Television system:

Tuner System: DVB-T
Channel Coverage: UK
UHF: 21 to 68 ch

RF converter output:

Not provided

Video:

Video system:
PAL colour signal, 625 lines, 50 fields
NTSC colour signal, 525 lines, 60 fields
Recording system:
MPEG2 (Hybrid VBR)
Video In (PAL/NTSC):
AV1/AV2 (21 pin), AV3 (pin jack) 1 Vp-p 75 Ω,
termination
S-Video In (PAL/NTSC):
AV2 (21 pin), AV3 (S terminal) 1 Vp-p 75 Ω, termination
RGB In (PAL): AV2 (21 pin) 0.7 Vp-p 75 Ω, termination
Video Out (PAL/NTSC):
AV1/AV2 (21 pin), Video Out (pin jack) 1 Vp-p 75
Ω, termination
S-Video Out (PAL/NTSC):
AV1 (21 pin), S-Video Out (S terminal) 1 Vp-p 75
Ω, termination
RGB Out (PAL/NTSC):
AV1 (21 pin) 0.7 Vp-p (PAL) 75 Ω, termination
Component video output (NTSC 480p/480i, PAL 576p/576i)
Y: 1.0 Vp-p 75 Ω, termination
PB: 0.7 Vp-p 75 Ω, termination
PR: 0.7 Vp-p 75 Ω, termination

Audio:

Recording system:
Dolby Digital (2 ch), Linear PCM (XP mode)
Audio In: AV1/AV2 (21 pin), AV3 (pin jack)
Input Level:
Standard: 0.5 Vrms, Full scale: 2.0 Vrms at 1 kHz
Input Impedance:
More than 10 kΩ
Audio Out:
AV1/AV2 (21 pin), Audio Out (pin jack)
Output Level:
Standard: 0.5 Vrms, Full scale: 2.0 Vrms at 1 kHz
Output Impedance:
Less than 1 kΩ
Digital Audio Out:
Optical terminal (PCM, Dolby Digital, DTS, MPEG)

DV Input: IEEE 1394 Standard, 4 Pin: 1 pc
HDMI Output: 19 pin type A: 1 pc
HDMI™ (V.1.3 with Deep Colour)

This unit supports "HDAVI Control 3" function.

Quick Start for Recording & EPG Display (Power Save : OFF)
1 Sec. Quick Start for Recording & EPG Display*

(when connecting to TV using 21-pin Scart, Component Video,
Video or S-Video terminals)

※From the power on, recording on DVD-RAM starts in about 1
second after the REC button is pressed. If the GUIDE button is
pressed while the unit is off, the Electronic Program Guide (EPG)
displays in less than 1 second. (Quick Start Mode)

Others

Regional Code: # 2

Operating temperature range:
5 °C to 40 °C

Operating humidity range:
10 % to 80 % RH (no condensation)

Dimensions (W × H × D):
430 mm × 59 mm × 330 mm

Mass: Approx. 3.2 kg



Notes

Specifications are subject to change without notice.

CAUTION!

THIS PRODUCT UTILIZES A LASER.
USE OF CONTROLS OR ADJUSTMENTS OR
PERFORMANCE OF PROCEDURES OTHER THAN THOSE
SPECIFIED HEREIN MAY RESULT IN HAZARDOUS
RADIATION EXPOSURE.
DO NOT OPEN COVERS AND DO NOT REPAIR YOURSELF.
REFER SERVICING TO QUALIFIED PERSONNEL.

CAUTION!

- DO NOT INSTALL OR PLACE THIS UNIT IN A BOOKCASE, BUILT-IN CABINET OR IN ANOTHER CONFINED SPACE. ENSURE THE UNIT IS WELL VENTILATED. TO PREVENT RISK OF ELECTRIC SHOCK OR FIRE HAZARD DUE TO OVERHEATING, ENSURE THAT CURTAINS AND ANY OTHER MATERIALS DO NOT OBSTRUCT THE VENTILATION VENTS.
- DO NOT OBSTRUCT THE UNIT'S VENTILATION OPENINGS WITH NEWSPAPERS, TABLECLOTHS, CURTAINS, AND SIMILAR ITEMS.
- DO NOT PLACE SOURCES OF NAKED FLAMES, SUCH AS LIGHTED CANDLES, ON THE UNIT.
- DISPOSE OF BATTERIES IN AN ENVIRONMENTALLY FRIENDLY MANNER.

WARNING:

TO REDUCE THE RISK OF FIRE, ELECTRIC SHOCK OR
PRODUCT DAMAGE,

- DO NOT EXPOSE THIS APPARATUS TO RAIN, MOISTURE, DRIPPING OR SPLASHING AND THAT NO OBJECTS FILLED WITH LIQUIDS, SUCH AS VASES, SHALL BE PLACED ON THE APPARATUS.
- USE ONLY THE RECOMMENDED ACCESSORIES.
- DO NOT REMOVE THE COVER (OR BACK); THERE ARE NO USER SERVICEABLE PARTS INSIDE. REFER SERVICING TO QUALIFIED SERVICE PERSONNEL.

CAUTION

Danger of explosion if battery is incorrectly replaced.
Replace only with the same or equivalent type
recommended by the manufacturer. Dispose of used
batteries according to the manufacturer's instructions.

THIS UNIT IS INTENDED FOR USE IN MODERATE CLIMATES.

This product may receive radio interference caused by mobile telephones during use. If such interference is apparent, please increase separation between the product and the mobile telephone.

The socket outlet shall be installed near the equipment and easily accessible.

The mains plug of the power supply cord shall remain readily operable. To completely disconnect this apparatus from the AC Mains, disconnect the power supply cord plug from AC receptacle.



(Back of product)

DANGER - VISIBLE AND INVISIBLE LASER RADIATION WHEN OPEN. AVOID DIRECT EXPOSURE TO BEAM. FDA 21 CFR/Class IIIb	
CAUTION - CLASS 3B VISIBLE AND INVISIBLE LASER RADIATION WHEN OPEN. AVOID EXPOSURE TO THE BEAM. IEC60825-1 +A2/Class 3B	
ATTENTION - RAYONNEMENT LASER VISIBLE ET INVISIBLE. CLASSE 3B. EN CAS D'OUVERTURE, EVITER UNE EXPOSITION AU FASCIAU.	
FORSIGTIG - SYNLIG OG USYNLIG LASERSTRÅLING KLASSE 3B. NÅR LÅGET ER ÅBENT, UNDGÅ AT BLIVE UDSAT FOR STRÅLEN.	
VARO - AVATTAESSA OLET ALTTIINA LUOKAN 3B NÄKYVÄÄ JA NÄKYMÄTÖNTÄ LASERSÄTEILYÄ, VARO ALITISTUMISTA SÄTEELLE.	
VARNING - KLASS 3B SYNLIG OCH OSYNLIG LASERSTRÅLNING NÄR DENNA DEL ÄR ÖPPNAD. UNDVIK EXPONERING FÖR STRÅLEN.	
VORSICHT - SICHTBARE UND UNSICHTBARE LASERSTRAHLUNG KLASSE 3B. WENN ABDECKUNG GEOFFNET, NICHT DEM STRAHL AUSSETZEN.	
注意 - 打开时有可见及不可见激光辐射。避免光束照射。	
注意 - ここを開くと可視及び不可視レーザー光が出ます。ビームを見たり、触れたりしないでください。 VQL1J70	

(Inside of product)

- For your safety, be sure not to connect or handle the equipment with wet hands.
- Your attention is drawn to the fact that recording pre-recorded tapes or discs or other published or broadcast material may infringe copyright laws.

-If you see this symbol-

Information for Users on Collection and Disposal of Old Equipment and used Batteries



These symbols on the products, packaging, and/or accompanying documents mean that used electrical and electronic products and batteries should not be mixed with general household waste.

For proper treatment, recovery and recycling of old products and used batteries, please take them to applicable collection points, in accordance with your national legislation and the Directives 2002/96/EC and 2006/66/EC.

By disposing of these products and batteries correctly, you will help to save valuable resources and prevent any potential negative effects on human health and the environment which could otherwise arise from inappropriate waste handling. For more information about collection and recycling of old products and batteries, please contact your local municipality, your waste disposal service or the point of sale where you purchased the items.

Penalties may be applicable for incorrect disposal of this waste, in accordance with national legislation.



For business users in the European Union

If you wish to discard electrical and electronic equipment, please contact your dealer or supplier for further information.

[Information on Disposal in other Countries outside the European Union]

These symbols are only valid in the European Union. If you wish to discard these items, please contact your local authorities or dealer and ask for the correct method of disposal.



Note for the battery symbol (bottom two symbol examples):

This symbol might be used in combination with a chemical symbol. In this case it complies with the requirement set by the Directive for the chemical involved.

Cd

Index

A Add New DVB Services	51	F Finalise	23, 49	I Ratings	52
Audio		Flexible Recording.....	24	Record	
DVB Multi Audio.....	47	Format disc.....	23, 48	Aspect.....	21
Language.....	46	FR (Flexible Recording) Mode.....	22	Direct TV Recording.....	23
Recording.....	21, 47	Freeview built-in	19	DV automatic recording	26
Settings.....	46, 47, 53	FUNCTION MENU Window.....	37	External Link.....	25
B Change Thumbnail	42, 45	G Guide	16, 19, 30	Flexible Recording	24
Channel		H HDMI	10, 38, 39, 60, 72	From a Satellite Receiver.....	25
Audio.....	46	I Initialize	56	From a video cassette recorder	26
Set Channels.....	50, 51	J JPEG	15, 34, 72	Important notes.....	21
Chapter	33, 43, 45	L Language		Mode.....	22
Chasing playback	24	Audio.....	46	Timer.....	19, 27
Child Lock	57	Code list.....	62	Repeat play	47
Cleaning		Soundtrack.....	46	Resume play function	17
Disc.....	13	Subtitle.....	46	RGB	
Lens.....	64	LPCM	53, 72	Input.....	55
Main unit.....	64	M Manual Skip.....	33	Output.....	55
Clock setting	12	Menu		S Satellite Receiver	
Close First Layer	49	MP3	35	Connection.....	9
Connection		On-screen.....	46	Recording	25
Aerial.....	8, 9, 58	Pictures.....	34	Watching	16
Amplifier, system component.....	60	Setup	50	Select channel	16
DV IN terminal	26	Mode		Serial number.....	7
HDMI.....	10, 60	Recording	22	Setup menu.....	50
Satellite receiver	9	Still mode.....	52	Shipping Condition	56
Television.....	8-10, 58-60	MP3	15, 35, 72	Signal Condition	51
Video cassette recorder.....	26, 58	N Name		Simultaneous rec and play	24
CPRM	72	Disc.....	48	Slide Show	34
Create Chapter	33, 43, 45	Entering text.....	40	Soundtrack.....	46
Create playlists	44	Playlist.....	45	Status messages	37
Create Top Menu	49	Title.....	27, 41	Still picture	
D Default Settings	56	New Service	37, 51, 54	Play.....	34
Delete		Noise reduction (NR).....	47	Subtitle	
All titles	48	O On-screen		Disc.....	46
Chapter.....	43, 45	Digital channel information	36	DVB Subtitle.....	36, 54
Playlist.....	44	Display.....	46	System Update.....	54
Title.....	20, 41	Status messages	37	T Thumbnail	42, 45, 73
DELETE Navigator	20	Optical digital audio cable.....	60	Time Slip.....	33
Dialog Enhancer	47	Owner ID.....	11, 56	Timer recording	19, 27
Digital Channel Information	36	P Partial Delete.....	41	Top Menu.....	17
Digital TEXT (MHEG)	36	PCM Down Conversion	53	Transfer	47
DIRECT NAVIGATOR	32, 34, 40	Picture settings.....	47, 52	Tuning	
Direct TV Recording	23	Playback discs.....	17	Auto-Setup.....	51
Divide Title	42	Settings.....	46, 47, 52	DVB Manual.....	51
DV automatic recording	26	Playback NR.....	47	TV Aspect.....	54
DVB Multi Audio	47	Playlist.....	44	TV Guide.....	16, 19, 30
DVB Subtitle	36, 54	Power Save.....	11, 56	TV System (PAL/NTSC)	55
DVD-RAM, DVD-R, DVD-R DL,		Profile	50	V VIERA Link	38, 39
DVD-RW, +R, +R DL, +RW	13	Progressive.....	47, 54	V.S.S.....	47
DVD-Video	14, 17	Properties		W Watching television	16
E Edit		Playlist	44	1 1080p	55, 73
Chapter.....	43	Still picture.....	35	2 21-pin Scart terminal.....	7, 8, 9, 10, 58
Playlist.....	44	Title.....	41		
Profile.....	50	Protection			
Title.....	40	Cartridge.....	48		
Enabling the second layer		Disc.....	48		
on DL discs to be		Title.....	41		
recordable - Close First Layer	49	Q Q Link	38		
Encrypted	36	Quick View (Play x1.3).....	32		
Enter name					
Disc.....	40, 48				
Playlist	40, 45				
Title.....	40, 41				
External Device	26				
EXT LINK	25				



Matsushita Electric Industrial Co., Ltd.
 Web Site: <http://panasonic.net>

Pursuant to at the directive 2004/108/EC, article 9(2)
 Panasonic Testing Centre
 Panasonic Marketing Europe GmbH
 Winsbergring 15, 22525 Hamburg, Germany

(En)

RQT9118-B
 H0408AY0