

Panasonic

Operating Instructions

Digital Cordless Answering System

Model No. **KX-TG7160E**
KX-TG7180E

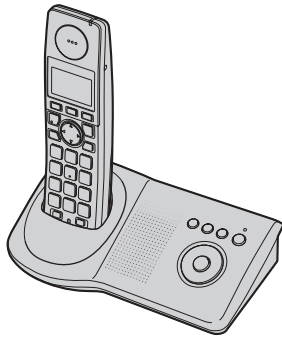

KX-TG7160



This unit is Caller ID compatible. To display the caller's phone number, you must subscribe to Caller ID service.

Charge the batteries for about 7 hours before initial use.

Please read these operating instructions before using the unit and save them for future reference.

Introduction

Introduction

Thank you for purchasing a new Panasonic digital cordless phone.

For your future reference

Attach or keep original receipt to assist with any repair under warranty.

Serial No. (found on the bottom of the base unit)

Date of purchase

Name and address of dealer

Note:

- This equipment is designed for use on the UK and Republic of Ireland analogue telephone network.
- In the event of problems, you should contact your equipment supplier in the first instance.

Declaration of Conformity:

- Panasonic Communications Co., Ltd. declares that this equipment is in compliance with the essential requirements and other relevant provisions of Radio & Telecommunications Terminal Equipment (R&TTE) Directive 1999/5/EC.

Declarations of Conformity for the relevant Panasonic products described in this manual are available for download by visiting:

<http://www.doc.panasonic.de>

Contact:

Panasonic Services Europe
a Division of Panasonic Marketing Europe GmbH
Panasonic Testing Centre
Winsbergring 15, 22525 Hamburg, Germany

Your phone

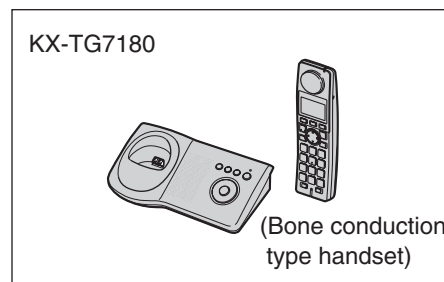
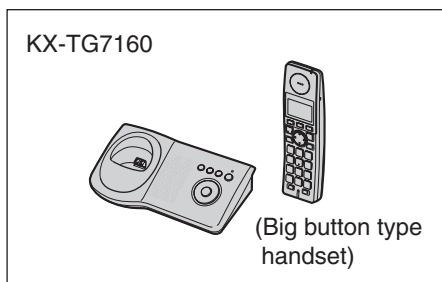

Note:

- The handsets have been pre-registered for use with their base unit. If not registered, see page 30.

Table of Contents

Preparation

Accessory information 4
 Expanding your phone system 6
 Important information 7
 Bone conduction earpiece (KX-TG7180 only) 8
 Controls 9
 Displays 10
 Connections 11
 Battery installation/replacement 11
 Battery charge 12
 Turning the power on/off 13
 Symbols used in these operating instructions 13
 Display language 13
 Date and time 13

Accessibility features

Voice announce 14

Making/Answering Calls

Making calls 15
 Answering calls 16

Phonebook

Handset phonebook 17
 Chain dial 18

Handset Settings

Handset settings 19
 Time settings 21

Base Unit Settings

Base unit settings 22

Caller ID Service

Using Caller ID service 23
 Caller list 23
 Voice mail service 24

Answering System Features

Answering system 25
 Turning the answering system on/off 25
 Greeting message 25
 Listening to messages 26
 Direct command operation using the

handset 27
 Remote operation 27
 Answering system settings 29

Multi-unit Operation

Operating additional units 30
 Registering a handset to the base unit 30
 Intercom between handsets 31
 Transferring calls between handsets 31
 Conference calls 32
 Copying phonebook entries 32

Useful Information

Using the belt clip 33
 Using the shoulder rest attachment 33
 Character entry 34
 Error messages 36
 Troubleshooting 36
 Specifications 40
 Conditions of guarantee 41

Index

Index 42

Preparation

Accessory information

Included accessories

No.	Accessory items	Quantity
①	AC adaptor for base unit Part No. PQLV207EZ (PQLV207E)	1
②	Telephone line cord Part No. PQJA87S or PQJA10180Z (for UK)	1
③	Rechargeable batteries AAA (R03) size Part No. HHR-55AAAB or HHR-4EPT	2
④	Handset cover* ¹ Part No. PQYNTG8100E	1
⑤	Belt clip Part No. PQKE10464Z1	1
⑥	Shoulder rest Part No. PQZXTG7160E	1

*1 The handset cover comes attached to the handset.

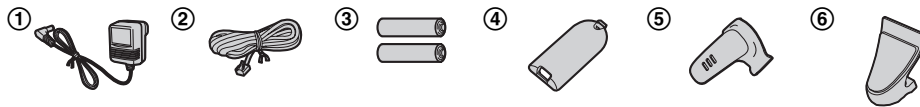

Preparation

Additional/replacement accessories

Please contact your nearest Panasonic dealer for sales information.

No.	Model No.	Description
①	P03P*1	2 rechargeable nickel metal hydride (Ni-MH) batteries, AAA (R03) size
②	KX-TCA717EX	Wall-Mounting Adaptor
③	KX-TCA94EX	Headset
④	KX-A272	DECT repeater

*1 Maximum capacity of 750mAh

②



③



Note:

- You can expand your phone system by registering additional compatible Panasonic handsets (page 6).

Preparation

Expanding your phone system

You can expand your phone system by registering the following optional handsets to a single base unit (KX-TG7160 or KX-TG7180): **max. 6**

Please contact your nearest Panasonic dealer for sales information.

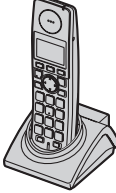
Handsets: max. 6	
Additional digital cordless handset KX-TGA711E 	Additional digital cordless handset KX-TGA715E (Big button type handset) 
Additional digital cordless handset KX-TGA717E (Bone conduction type handset) 	

Handset feature overview for KX-TGA711, KX-TGA715, and KX-TGA717

Operations and features of the 3 different accessory handsets have certain differences as indicated in the table below.

Feature	KX-TGA711	KX-TGA715	KX-TGA717	Page
Description	Available as accessory handset only	Same handset supplied with KX-TG7160	Same handset supplied with KX-TG7180	—
Big button	—	●	●	—
Bone conduction earpiece	—	—	●	page 8
Call restriction	●	—	—	—
Headset jack	—	●	●	page 9
Voice announce	—	●	●	page 14

Preparation

Important information

General

- Use only the AC adaptor included with this product, noted on page 4.
- Do not connect the AC adaptor to any AC outlet other than a standard 220–240 V AC outlet.
- This product is unable to make calls when:
 - the portable handset battery(ies) need recharging or have failed.
 - there is a power failure.
- Do not open the base unit, charger, or handset other than to replace the battery(ies).
- This product should not be used near emergency/intensive care medical equipment and should not be used by people with pacemakers.
- Care should be taken that objects do not fall onto, and liquids are not spilled into, the unit. Do not subject this product to excessive smoke, dust, mechanical vibration or shock.

Environment

- Do not use this product near water.
- This product should be kept away from heat sources such as radiators, cookers, etc. It should also not be placed in rooms where the temperature is less than 5 °C or greater than 40 °C.
- The AC adaptor is used as the main disconnect device. Ensure that the AC outlet is installed near the product and is easily accessible.

Warning:

- To prevent the risk of electrical shock, do not expose this product to rain or any other type of moisture.
- Unplug this product from power outlets if it emits smoke, an abnormal smell, or

makes unusual noise. These conditions can cause fire or electric shock. Confirm that smoke has stopped emitting and contact an authorised service centre.

Battery caution

- We recommend using the battery(ies) noted on page 5. **Use only rechargeable battery(ies).**
- Do not mix old and new batteries.
- Do not dispose of the battery(ies) in a fire, as they may explode. Check with local waste management codes for special disposal instructions.
- Do not open or mutilate the battery(ies). Released electrolyte from the battery(ies) is corrosive and may cause burns or injury to the eyes or skin. The electrolyte may be toxic if swallowed.
- Exercise care when handling the battery(ies). Do not allow conductive materials such as rings, bracelets or keys to touch the battery(ies), otherwise a short circuit may cause the battery(ies) and/or the conductive material to overheat and cause burns.
- Charge the battery(ies) in accordance with the information provided in these operating instructions.
- Only use the included base unit (or charger) to charge the battery(ies). Do not tamper with the base unit (or charger). Failure to follow these instructions may cause the battery(ies) to swell or explode.

Information on Disposal for Users of Waste Electrical & Electronic Equipment (private households)



Preparation

This symbol on the products and/or accompanying documents means that used electrical and electronic products should not be mixed with general household waste. For proper treatment, recovery and recycling, please take these products to designated collection points, where they will be accepted on a free of charge basis. Alternatively, in some countries you may be able to return your products to your local retailer upon the purchase of an equivalent new product.

Disposing of this product correctly will help to save valuable resources and prevent any potential negative effects on human health and the environment which could otherwise arise from inappropriate waste handling. Please contact your local authority for further details of your nearest designated collection point.

Penalties may be applicable for incorrect disposal of this waste, in accordance with national legislation.

For business users in the European Union

If you wish to discard electrical and electronic equipment, please contact your dealer or supplier for further information.

Information on Disposal in other Countries outside the European Union

This symbol is only valid in the European Union.

If you wish to discard this product, please contact your local authorities or dealer and ask for the correct method of disposal.

Bone conduction earpiece (KX-TG7180 only)

The handset features a bone conduction earpiece that uses vibrations to create sound during your telephone conversations. For proper operation press the bone conduction earpiece against your face near the ear.

Normally, sound enters the ear canal and vibrates the eardrum. People feel the vibration within the inner ear and comprehend it as it is received by the auditory nerve.

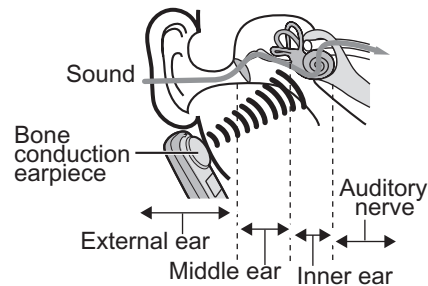

Place the bone conduction earpiece against your face (not your ear). Try different locations to find which location works best. Start with the temple area.



Note:

- Do not place the bone conduction earpiece on a hearing aid. Howling or other interference may be heard.
- The effectiveness of the bone conduction earpiece will vary by the type and degree of hearing loss of the user.

Preparation

- As sound is generated by vibration, users with normal hearing can use the handset by placing the bone conduction earpiece against the ear, as an ordinary telephone.
- If the bone conduction earpiece gets dusty or greasy, clean it with a soft, dry cloth.

Controls

Handset (KX-TG7160)

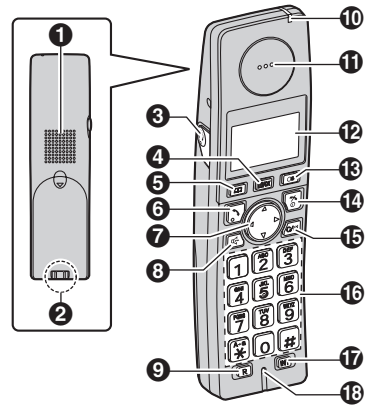

Handset (KX-TG7180)

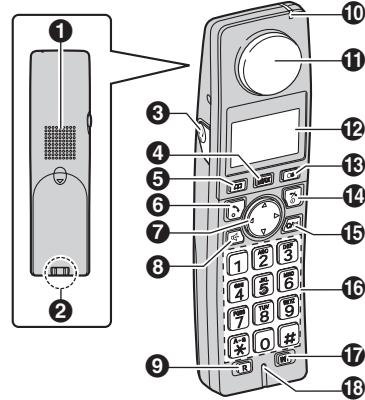

- ❶ Speaker
- ❷ Charge contact
- ❸ Headset jack
- ❹ [≡/OK] (Menu/OK)
- ❺ [☐] (Phonebook)
- ❻ [↩] (Talk)
- ❼ Navigator key ([▲]/[▼]/[▶]/[◀])
- ❽ [📞] (Speakerphone)

Preparation

- ⑨ [R] (Recall)
- ⑩ Charge indicator/Ringer indicator/
Message indicator
- ⑪ KX-TG7160
Receiver
KX-TG7180
Bone conduction earpiece
- ⑫ Display
- ⑬ [●] (Redial/Pause)
- ⑭ [⏻] (Off/Power)
- ⑮ [C/⊗] (Clear/Mute)
- ⑯ Dial keypad
- ⑰ [INT] (Intercom)
- ⑱ Microphone

Base unit

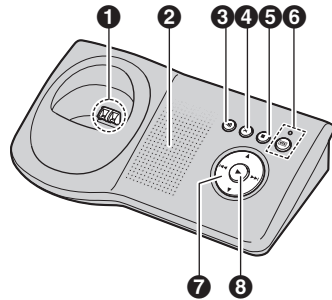

- ① Charge contact
- ② Speaker
- ③ [📞] (Page)
- ④ [✕] (Erase)
- ⑤ [■] (Stop)
- ⑥ Answer on indicator/[📞] (Answer on)
- ⑦ Navigator key: [▲]/[▼]/[◀◀]/[▶▶]
- ⑧ [▶] (Play)/Message indicator

Displays

Display icons

Display icon	Meaning
📶	Within range of a base unit <ul style="list-style-type: none"> ● When flashing: Handset is searching for base unit. (out of range of base unit, handset is not registered to base unit, no power on base unit)
📶	Handset is accessing base unit. (intercom, paging, changing base unit settings, etc.)
📞	Handset is on an outside call.
📞	Answering system is on. (page 25)
🔋	Battery strength
[2]	Handset number (Standby display setting, page 19)
[IN USE]	<ul style="list-style-type: none"> ● Line is being used by another handset. ● Answering system is being used by another handset or the base unit.

Preparation

Connections

When connecting the AC adaptor to the base unit, a short beep will be heard. If it is not heard, check the connections.

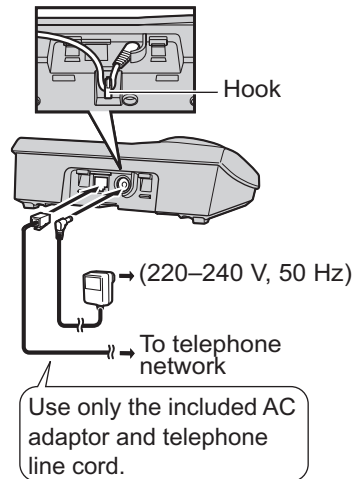

Note:

- Never install telephone wiring during a lightning storm.
- The AC adaptor must remain connected at all times. (It is normal for the adaptor to feel warm during use.)
- The AC adaptor should be connected to a vertically oriented or floor-mounted AC outlet. Do not connect the AC adaptor to a ceiling-mounted AC outlet, as the weight of the adaptor may cause it to become disconnected.
- **The unit will not work during a power failure.** We therefore recommend you also connect a corded-type telephone (without AC adaptor) to the same telephone line using a T-adaptor. Your Panasonic sales shop can offer you more information about connection possibilities.

Location

- For maximum distance and noise-free operation, place your base unit:

- away from electrical appliances such as TVs, radios, personal computers or other phones.
- in a convenient, high and central location.

Battery installation/replacement

Important:

- Use only the included rechargeable batteries noted on page 4, 7.
- When replacing batteries, we recommend using the Panasonic rechargeable batteries noted on page 5, 7.
- Wipe the battery ends (+, -) with a dry cloth.
- When installing the batteries, avoid touching the battery ends (+, -) or the unit contacts.

- 1 Press the notch on the handset cover firmly and slide it in the direction of the arrow.
 - When replacing batteries, remove the old batteries positive (+) end first.

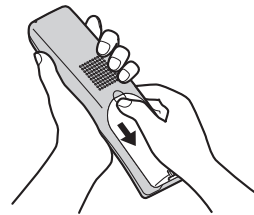

- 2 Insert the batteries negative (-) end first. Close the handset cover.

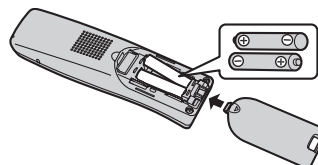

Preparation

Battery charge

Place the handset on the base unit for about 7 hours before initial use.

When charging, the battery icon is shown as follows.



When the batteries are fully charged,  remains on the display.

- The charge indicator lights up when the handset is placed on the base unit.

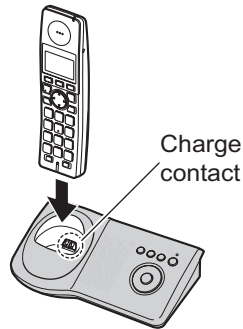



- The pictured model is KX-TG7160.

Note:

- It is normal for the handset to feel warm during charging.
- If you want to use the unit immediately, charge the batteries for at least 15 minutes.
- Clean the charge contacts of the handset and base unit with a soft, dry cloth once a month, otherwise the batteries may not charge properly. Clean more often if the unit is exposed to grease, dust, or high humidity.

Battery strength

Battery icon	Battery strength
	High
	Medium
	Low When flashing: Needs to be charged.

Panasonic Ni-MH battery performance (included batteries)

Operation	Operating time
In continuous use	KX-TG7160: 12 hours max. KX-TG7180: 10 hours max.
In continuous standby mode	150 hours max.

Note:

- It is normal for batteries not to reach full capacity at the initial charge. Maximum battery performance is reached after a few complete cycles of charge/discharge (use).
- Actual battery performance depends on a combination of how often the handset is in use and how often it is not in use (standby).
- Battery operating time may be shortened over time depending on usage conditions and ambient temperature.
- Even after the handset is fully charged, the handset can be left on the base unit without any ill effect on the batteries.
- The battery strength may not be displayed correctly after you replace the batteries. In this case, place the handset on the base unit and charge for at least 7 hours.

Preparation

Turning the power on/off

Power on

Press [**⏻**] for about 1 second.

Power off

Press [**⏻**] for about 2 seconds.

Symbols used in these operating instructions

Symbol	Meaning
[⏻ /OK]	Press [⏻ /OK].
→	Proceed to the next operation.
" "	Select the words in quotations shown on the display (e.g., "Handset Setup") by pressing [▲] or [▼].

Display language

- 1 [**⏻**] → [**⏻**/OK]
- 2 Press [**▲**] or [**▼**] to select "Handset Setup". → [**▶**]
- 3 Press [**▲**] or [**▼**] to select "Display Setup". → [**▶**]
- 4 Press [**▲**] or [**▼**] to select "Select Language". → [**▶**]
- 5 Press [**▲**] or [**▼**] to select the desired language. → [**▶**] → [**⏻**]

Note:

- If you select a language you cannot read, press [**⏻**], press [**⏻**/OK], press [**▲**] 3 times, press [**▶**], press [**▼**] 2 times, press [**▶**], press [**▼**], press [**▶**], select the desired language, press [**▶**], then press [**⏻**].

- To change the voice announce language, see page 14.

Date and time

- 1 [**⏻**/OK]
- 2 Press [**▲**] or [**▼**] to select "Handset Setup". → [**▶**]
- 3 Press [**▲**] or [**▼**] to select "Time Settings". → [**▶**]
- 4 Press [**▲**] or [**▼**] to select "Set Date & Time". → [**▶**]
- 5 Enter the current day, month, and year.
Example: 17 May, 2006
[1][7] [0][5] [0][6]
- 6 Enter the current hour and minute.
Example: 3:30 PM
[0][3] [3][0] → Press [*****] until "03:30 PM" is displayed.
- 7 [**⏻**/OK] → [**⏻**]

Note:

- To correct a digit, press [**◀**] or [**▶**] to move the cursor to the digit, then make the correction.
- The date and time may be incorrect after a power failure. In this case, set the date and time again.

Accessibility features

Voice announce

The voice announce features allow the handset to announce displayed phone number. (**Caller ID announce/List announce**)

Caller ID announce

When you receive an outside call which has phone number information, the handset announces the displayed phone number from the handset speaker.

- To announce outside caller's phone number, you must first subscribe to Caller ID service (page 23).
- The announcement is heard at the ringer volume (page 19).

List announce

The handset announces phone numbers from the handset speaker while you are viewing the **redial list**, **caller list**, and **phonebook**.

- If the displayed phone number has a P(pause), the handset inserts a 0.5 second pause for each P and if the number has the other symbols, (for example, *, #, etc.) the handset skips the symbols and announces the next number.

Setting volume for voice announce

You can set the volume for **list announce**. The volume for caller ID announce is set when setting the ringer volume on (page 19).

- 1 [≡/OK]
- 2 "Handset Setup" → [▶]
- 3 "Other Options" → [▶]
- 4 "Voice Announce" → [▶]
- 5 "Volume" → [▶]
- 6 Select the desired volume.

- To turn the voice announce feature off, select the volume "Off".

7 [▶] → [✕⊙]

Note:

- The caller ID announce is heard at the handset ringer volume (page 19). When the volume for voice announce is set to "Off", the handset does not announce the phone number regardless of the ringer volume.

Selecting language for voice announce

- 1 [≡/OK]
- 2 "Handset Setup" → [▶]
- 3 "Other Options" → [▶]
- 4 "Voice Announce" → [▶]
- 5 "Select Language" → [▶]
- 6 Select the desired language. → [▶] → [✕⊙]

Note:

- To change the display language, see page 13.

Making/Answering Calls

Making calls

- 1 Lift the handset and dial the phone number.
 - To correct a digit, press **[C/⊗]**, then enter the correct number.
- 2 **[↶]**
- 3 When finished talking, press **[⊗]** or place the handset on the base unit.

Speakerphone

- 1 During a conversation, press **[☎]** to turn on the speakerphone.
 - Speak alternately with the caller.
- 2 When finished talking, press **[⊗]**.

Note:

- For best performance, use the speakerphone in a quiet environment.
- To switch back to the receiver, press **[↶]**.

To adjust the receiver or speaker volume

Press **[▲]** or **[▼]** while on a call.

Redial feature

Previously dialled phone numbers (each 24 digits max.) can be redialled.

To make a call using the redial list

The last 10 phone numbers dialled are stored in the redial list.

- 1 **[☎]**
- 2 Press **[▲]** or **[▼]** to select the desired number.
- 3 **[↶]** / **[☎]**

To erase numbers in the redial list

- 1 **[☎]**
- 2 Press **[▲]** or **[▼]** to select the desired number. → **[▶]**

- 3 “Erase” → **[▶]**

- 4 “Yes” → **[▶]** → **[⊗]**

Other features

Mute

While mute is turned on, you will be able to hear the other party, but the other party will not be able to hear you.

To mute your voice, press **[C/⊗]**.

- To return to the conversation, press **[C/⊗]** again.

Call waiting - [R] button

If a second call is received while in a conversation with the first caller, a beep tone will be heard. Press **[R]** button to switch between callers.

This service requires a subscription. Consult your service provider/telephone company for details.

Note:

- If your unit is connected to a PBX (private branch exchange), pressing **[R]** can allow you to access certain features of your host PBX such as transferring an extension call. Consult your PBX dealer for details.
- You can change the recall time (page 22).

Pause button (for PBX/long distance service users)

A pause is sometimes required when making calls using a PBX or long distance service.

Example: If you have to dial **[0]** before dialling outside numbers manually, you will probably need to pause after dialling **[0]** until you hear a dial tone.

- 1 **[0]** → **[☎]**
- 2 Dial the phone number. → **[↶]** / **[☎]**

Note:

- A 3 second pause is inserted each time **[☎]** is pressed. Press repeatedly to insert longer pauses.

Making/Answering Calls

Answering calls

- 1 Lift the handset and press [📞] or [📞] when the unit rings.
 - You can also answer a call by pressing any dial key from [0] to [9], [*], [#], or [INT]. (**Any key answer feature**)
- 2 When finished talking, press [📞] or place the handset on the base unit.

Auto talk feature

You can answer calls simply by lifting the handset off the base unit. You do not need to press [📞]. To turn this feature on, see page 19.

To adjust the handset ringer volume when receiving a call

Press [▲] or [▼].

Handset locator

Using this feature, you can locate the handset if it has been misplaced.

- 1 Press [📞] on the base unit.
- 2 To stop paging, press [📞] on the base unit or press [📞] on the handset.

Phonebook

Handset phonebook

The handset phonebook allows you to make calls without having to dial manually. You can add 50 names and phone numbers to the handset phonebook.

Adding entries to the handset phonebook

- 1 [] → []/OK
- 2 "New Entry" → [▶]
- 3 Enter the party's name (16 characters max.; page 34). → []/OK
- 4 Enter the party's phone number (24 digits max.). → []/OK
- 5 "Save" → [▶] → [✕⊙]

Note:

- Step 1 variation:
[]/OK → Press [▲] or [▼] to select "Ph. Book Setup". → [▶]

Finding and calling a handset phonebook entry

Handset phonebook entries can be searched for by first character or by scrolling through all handset phonebook entries. When you have found the desired entry, press [↶].

Scrolling through all entries

- 1 []
- 2 Press [▲] or [▼] to display the desired entry.

Searching by first character (index search)

- 1 []
- 2 Press the dial key ([0] to [9]) which contains the character you are searching for (page 34).

- Press the same dial key repeatedly to display the first entry corresponding to each letter located on that dial key.
- If there is no entry corresponding to the letter you selected, the next entry will be displayed.
- To change the character entry mode:
[●] → Select the character entry mode. → [▶]

- 3 Press [▲] or [▼] to scroll through the phonebook if necessary.

Editing entries in the handset phonebook

Changing a name, phone number

- 1 Find the desired entry (page 17). → []/OK
- 2 "Edit" → [▶]
- 3 Edit the name if necessary (16 characters max.; page 34). → []/OK
- 4 Edit the phone number if necessary (24 digits max.). → []/OK
- 5 "Save" → [▶] → [✕⊙]

Erasing entries from the handset phonebook

Erasing an entry

- 1 Find the desired entry (page 17). → []/OK
- 2 "Erase" → [▶]
- 3 "Yes" → [▶] → [✕⊙]

Erasing all entries

- 1 [] → []/OK
- 2 "Erase All" → [▶]
- 3 "Yes" → [▶]
- 4 "Yes" → [▶] → [✕⊙]

Phonebook

Chain dial

This feature allows you to dial phone numbers in the handset phonebook while you are on a call. This feature can be used, for example, to dial a calling card access number or bank account PIN that you have stored in the handset phonebook, without having to dial manually.

- 1 While on a call, press [□].
- 2 Press [▲] or [▼] to select the desired entry.
 - To search by first character (index search), see page 17.
- 3 Press [▶] to dial the number.

Handset Settings

Handset settings

- When customising the handset, the current item or setting is indicated by ►.

To customise the handset:

- 1 [☰/OK]
- 2 Press [▲] or [▼] to select “Handset Setup”. → [►]
- 3 Press [▲] or [▼] to select the desired item in the handset settings menu. → [►]
- 4 Press [▲] or [▼] to select the desired item in the sub-menu. → [►]
 - In some cases, you may need to select from a second sub-menu. → [►]
- 5 Press [▲] or [▼] to select the desired setting then press [►] or follow the instruction in the rightmost column of the chart.
 - To exit the operation, press [✕⓪].

Handset settings menu	Sub-menu	Sub-menu 2	Feature (default setting)
Time Settings	Set Date & Time	—	Date and time: page 13
	Alarm	—	Set the alarm: page 21
Ringer Setup	Ringer Volume	—	Handset ringer volume (<i>Maximum</i>) ^{*1}
	Ext. Ringtone (<i>External ringtone</i>)	—	Ringtones for outside calls (“Ringtone 1”) ^{*2*3}
	Int. Ringtone (<i>Intercom ringtone</i>)	—	Ringtones for intercom calls (“Ringtone 3”) ^{*3}
Display Setup	Standby Display	—	Standby mode display (“Off”) ^{*4}
	Select Language	—	Display language (“English”): page 13
	Contrast	—	Display contrast (<i>Level 3</i>)
Registration	Register H.set (<i>Register handset</i>)	—	page 30
Other Options	New Msg. Alert (<i>New message alert</i>)	—	New message alert (“Off”) ^{*5}
	Keytones	—	Keytones on/off (“On”)
	Auto Talk	—	Auto talk on/off (“Off”) ^{*6}
	Voice Announce	Volume	
Select Language			Voice announce language (“English”): page 14



Handset Settings

- *1 When the ringer is turned off, the handset will ring:
 - at the minimum level for alarm
 - at the minimum level for intercom calls
 - at the maximum level for paging
- *2 If you select one of the melody ringtones, the ringtone will continue to sound for several seconds if the caller hangs up before you answer. You may hear a dial tone or no one on the line when you answer a call.
- *3 The preset melodies in this product are used with permission of © 2006 Copyrights Vision Inc.
- *4 If “**Off**” is selected, only current date and time are displayed.
If “**Handset Number**” is selected and the current handset number is 2, “[2]” is displayed.
- *5 This feature alerts you when new messages have been recorded:
 - Answering system (page 25)The message indicator on the handset flashes until you have listened to all new messages.
While message alert is on, battery operating time is shortened (page 12).
- *6 Auto talk feature allows you to answer calls simply by lifting the handset off the base unit. You do not need to press [↶].

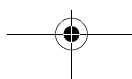
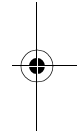
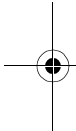

Time settings

Alarm

An alarm will sound for 3 minutes at the set time once or daily. Set the date and time beforehand (page 13).

- 1 **[☰/OK]** → “Handset Setup” → **[▶]**
- 2 “Time Settings” → **[▶]**
- 3 “Alarm” → Press **[▶]** 2 times.
- 4 Select an alarm mode. → **[▶]**

Off	Turns alarm off. Press [▶] again, then press [✕⊙] to finish.
Once	The alarm sounds once at the set time. Enter the desired day and month.
Daily	An alarm sounds daily at the set time.

- 5 Enter the desired hour and minute. → **[☰/OK]**
- 6 Select the desired ringtone. → **[▶]**
- 7 “Save” → **[▶]** → **[✕⊙]**

Note:

- To stop the alarm, press any dial key.
- When in talk or intercom mode, the alarm will not sound until the call has ended.
- If you select “Once”, the setting will change to “off” after the alarm sounds.

Base Unit Settings

Base unit settings

- Use the handset to customise the base unit.
- When customising the base unit, the current item or setting is indicated by ►.

To customise the base unit:

- 1 [≡/OK]
- 2 Press [▲] or [▼] to select “**Base Unit Setup**”. → [►]
- 3 Press [▲] or [▼] to select the desired item in the base unit settings menu. → [►]
- 4 Press [▲] or [▼] to select the desired item in the sub-menu. → [►]
- 5 Press [▲] or [▼] to select the desired setting then press [►] or follow the instruction in the rightmost column of the chart.
 - To exit the operation, press [✕⊙].

Base unit settings menu	Sub-menu	Feature (default setting)
Ringer Volume	—	Base unit ringer volume (<i>Medium</i>)
Call Options	Recall/Flash	Change the recall time (“100 msec.”). ^{*1}
Other Options	Base Unit PIN	Change base unit PIN (“0000”). ^{*2} – Enter the current 4-digit base unit PIN. → Enter the new 4-digit base unit PIN. → [≡/OK]
	Repeater Mode	(“off”): page 31

*1 Change the recall time, if necessary, depending on the requirements of your service provider/telephone company or PBX.

*2 If you change the PIN, please make note of your new PIN. The unit will not reveal the PIN to you. If you forget your PIN, consult your nearest Panasonic service centre.

Caller ID Service

Using Caller ID service

Important:

- This unit is Caller ID compatible. To use Caller ID features (such as displaying caller phone numbers), you must subscribe to Caller ID service. Consult your service provider/telephone company for details.

Caller ID features

When an outside call is received, the caller's phone number will be displayed.

- Phone numbers of the last 50 callers will be logged in the caller list.
- While listening to a message recorded by the answering system using the handset, you can call back the caller without having to dial the phone number (page 27).
- When caller information is received and it matches a phone number stored in the unit's phonebook, the stored name will be displayed and logged in the caller list.
- If the unit is connected to a PBX system, you may not receive the caller information.
- When the caller dialed from an area which does not provide Caller ID service, "Out of Area" will be displayed.
- When the caller requested not to send caller information, either no information or "Private Caller" will be displayed.

Missed calls

If a call is not answered, the unit treats the call as a missed call. The number of missed calls is shown on the display. This lets you know if you should view the caller list to see who called while you were out.

Call Waiting Caller ID

This is a service of your service provider/telephone company and will only operate if you have subscribed to this service. When you hear a call waiting tone

during a conversation, the display will show the second caller's information. You can answer the second call by pressing **[R]**. The first caller will be placed on hold. Press **[R]** again to switch back to the first caller. Consult your service provider/telephone company for details of this service.

Caller ID announce

When you receive an outside call which has phone number information, the handset announces the displayed phone number from the handset speaker.

- To announce outside caller's phone number, you must first subscribe to Caller ID service. Consult your service provider/telephone company for details.
- When receive a call while on the phone, the 2nd caller's phone number will not be announced even if you subscribe to both Caller ID and Call Waiting Caller ID services.
- The announcement is heard at the ringer volume (page 19).
- This feature can be turned on or off (page 14).

Caller list

Viewing the caller list and calling back

- 1 **[☰/OK]** → "Caller List" → **[▶]**
- 2 Press **[▼]** to search from the most recent call, or press **[▲]** to search from the oldest call.
 - If the item has already been viewed or answered, "✓" is displayed, even if it was viewed or answered using another handset.
- 3 **[↶]** / **[☎]**

Caller ID Service

Editing a caller's phone number before calling back

- 1 **[☰/OK]** → "Caller List" → **[▶]**
- 2 Press **[▲]** or **[▼]** to display the desired entry.
- 3 **[☰/OK]** → "Edit and Call" → **[▶]**
- 4 Edit the number.
 - Press dial key (**[0]** to **[9]**) to add, **[C/✖]** to delete.
- 5 **[↶]** / **[☎]**

Erasing caller information

- 1 **[☰/OK]** → "Caller List" → **[▶]**
- 2 Press **[▲]** or **[▼]** to display the desired entry. → **[☰/OK]**
- 3 "Erase" → **[▶]**
 - To erase all entries, select "Erase All". → **[▶]**
- 4 "Yes" → **[▶]** → **[✖⓪]**

Storing caller information into the handset phonebook

- 1 **[☰/OK]** → "Caller List" → **[▶]**
- 2 Press **[▲]** or **[▼]** to display the desired entry. → **[☰/OK]**
- 3 "Add Phonebook" → **[▶]**
- 4 Continue from step 3, "Adding entries to the handset phonebook", page 17.

Voice mail service

Voice mail is an automatic answering service offered by your service provider/telephone company. If you subscribe to this service, your service provider/telephone company's voice mail system will answer calls for you when you

are unavailable to answer the phone or when your line is busy. Messages are recorded by your service provider/telephone company, not your telephone. Please consult your service provider/telephone company for details of this service.

Note:

- For more information on using the unit's answering system and your service provider/telephone company's voice mail service, see page 29.

Answering System Features

Answering system

The unit contains an answering system which can answer and record calls for you when you are unavailable to answer the phone.

Important:

- Only 1 person can access the answering system (listen to messages, record a greeting message, etc.) at a time.
- When callers leave messages, the unit records the day and time of each message. Make sure the date and time have been set (page 13).

Memory capacity

The total recording capacity (including your greeting message and caller messages) is about 20 minutes. A maximum of 64 messages can be recorded.

Note:

- If message memory becomes full:
 - “Answer Sys. Full” is shown on the handset display
 - the answer on indicator on the base unit flashes rapidly

Turning the answering system on/off

Using the base unit

Press **[ON]** to turn on/off the answering system.

- When the answering system is turned on, the answer on indicator lights up.

Using the handset

- 1 **[M/OK]** → “Answer System” → **[▶]**

- 2 “Answer On” or “Answer Off” → **[▶]** → **[*0]**

Note:

- When the answering system is turned on, **[ON]** is displayed.

Greeting message

When the unit answers a call, callers are greeted by a greeting message. You can record your own greeting message or use a prerecorded greeting message.

Recording a greeting message

You can record your own greeting message (2 minutes and 30 seconds max.).

- 1 **[M/OK]** → “Answer System” → **[▶]**
- 2 “Record Greeting” → **[▶]**
 - Hold the handset about 20 cm away and speak clearly into the microphone.
- 3 Press **[M/OK]** to stop recording. → **[*0]**

Using a prerecorded greeting message

If you erase or do not record your own greeting message, the unit will play a prerecorded greeting message for callers and ask them to leave messages. If the message recording time (page 29) is set to “Greeting Only”, caller messages will not be recorded and the unit will play a different prerecorded greeting message asking callers to call again.

Playing back the greeting message

- 1 **[M/OK]** → “Answer System” → **[▶]**
- 2 “Play Greeting” → **[▶]** → **[*0]**

Answering System Features

Erasing the greeting message

If you erase your own greeting message, the unit will play a prerecorded greeting message for callers.

- 1 **[/OK]** → “Answer System” → **[▶]**
- 2 “Erase Message” → **[▶]**
- 3 “Erase Greeting” → **[▶]**
- 4 “Yes” → **[▶]** → **[]**

Listening to messages

Messages are stored and played back chronologically, from oldest message to newest.

Listening to new/all messages

When you have new messages:

- **[▶]** on the base unit flashes
- the message indicator on the handset flashes if the message alert feature (page 19) has been turned on

Note:

- To adjust the speaker volume during playback, press **[▲]** or **[▼]**.

Using the base unit

Press **[▶]**.

- If new messages have been recorded, the base unit plays back new messages.
- If there are no new messages, the base unit plays back all messages.

Note:

- After playing back all of the new messages, **[▶]** will stop flashing but the answer on indicator will remain lit up when the answering system is turned on.

Using the handset

- 1 **[/OK]** → “Answer System” → **[▶]**
- 2 “Play New Msg.” or “Play All Msg.” → **[▶]**

Repeating, skipping, stopping, and erasing a message during playback

- To repeat a message during playback:
 - for the base unit, press **[◀◀]**
 - for the handset, press **[◀]**
 If pressed within the first 5 seconds of a message, the previous message will be played.
- To skip a message during playback:
 - for the base unit, press **[▶▶]**
 - for the handset, press **[▶]**
- To stop a message during playback:
 - for the base unit, press **[■]**
 - for the handset, press **[9]**
- To erase a message during playback:
 - for the base unit, press **[X]**
 - for the handset, press **[*][4]**

Erasing all messages

Using the base unit

Press **[X]** 2 times.

Using the handset

- 1 **[/OK]** → “Answer System” → **[▶]**
- 2 “Erase Message” → **[▶]**
- 3 “Erase All” → **[▶]**
- 4 “Yes” → **[▶]** → **[]**

Answering System Features

Calling back (Caller ID subscribers only)

If caller information was received for the call, you can call the caller back while listening to a message.

- 1 Press **[M/OK]** during playback.
- 2 "Call Back" → **[▶]**

Editing the number before calling back

- 1 Press **[M/OK]** during playback.
- 2 "Edit and Call" → **[▶]**
- 3 Edit the number. → **[↶]** / **[↷]**

Direct command operation using the handset

You can operate the answering system by pressing dial keys, rather than navigating through the menus. To use the following commands, press **[M/OK]**. → "Answer System" → **[▶]**

Key	Direct commands
[1]	Repeat message (during playback)* ¹
[2]	Skip message (during playback)
[3]	Enter the "Settings" menu
[4]	Play new messages
[5]	Play all messages
[6]	Play greeting message
[7][6]	Record greeting message
[8]	Turn answering system on
[9]	Stop (recording, playback)
[0]	Turn answering system off
[*][4]	Erase this message (during playback)

Key	Direct commands
[*][5]	Erase all messages
[*][6]	Erase greeting message

*1 If pressed within the first 5 seconds of a message, the previous message will be played.

Remote operation

Using a touch tone phone, you can call your phone number from outside and access the unit to listen to messages or change answering system settings. The unit's voice guidance will prompt you to press certain dial keys to perform different operations.

Important:

- In order to operate the answering system remotely, you must first turn on remote operation by setting a remote access code. This code must be entered each time you operate the answering system remotely.

Turning remote operation on

A 3-digit remote access code must be entered when operating the answering system remotely. This code prevents unauthorised parties from listening to your messages remotely. After you store your remote access code, remote operation is possible.

- 1 **[M/OK]** → "Answer System" → **[▶]**
- 2 "Settings" → **[▶]**
- 3 "Remote Code" → **[▶]**
- 4 To turn on remote operation, enter a 3-digit remote access code.
 - To turn off remote operation, press **[*]**.
- 5 **[M/OK]** → **[↶⊙]**

Answering System Features

Note:

- If you have stored the remote access code, you can turn on the answering system by calling the unit even when it is turned off.

Using the answering system remotely

- 1 Dial your phone number from a touch tone phone.
- 2 After the greeting message starts, enter your remote access code.
 - The unit will announce the number of new messages.
 - After 3 seconds, voice guidance starts.
- 3 Follow the voice guidance prompts as necessary.

Note:

- You can hang up at any time.
- You can ignore the voice guidance and control the unit using remote commands (page 28).

Voice guidance

During remote operation, the unit's voice guidance will prompt you to press **[1]** to perform a specific operation, or press **[2]** to listen to more available operations.

Note:

- If less than 5 minutes of recording time is available, the unit will announce the remaining recording time after the last message is played back.

Remote commands

You can press dial keys to access certain answering system functions without waiting for the voice guidance to prompt you.

Key	Remote command
[1]	Repeat message (during playback) ^{*1}

Key	Remote command
[2]	Skip message (during playback)
[4]	Play new messages
[5]	Play all messages
[6]	Play greeting message
[7]	Record greeting message
[9]	Stop (recording, playback)
[0]	Turn answering system off
[*][4]	Erase this message (during playback)
[*][5]	Erase all messages
[*][6]	Erase greeting message (during greeting message playback)
[*][#]	End remote operation (or hang up)

*1 If pressed within the first 5 seconds of a message, the previous message will be played.

Turning on the answering system remotely

If the answering system is off, you can turn it on remotely.

- 1 Dial your phone number from a touch tone phone.
- 2 Let the phone ring 20 times.
 - A long beep will be heard.
- 3 Enter your remote access code within 10 seconds after the long beep.
 - The greeting message is played back.
 - You can hang up, or enter your remote access code again and begin remote operation.

Answering System Features

Answering system settings

Answering system setting	Default setting	Page
Answering system on/off	Answer On	page 25
Remote access code	—	page 27
Number of rings	4 Rings	page 29
Caller's recording time	3 Minutes	page 29
Call screening	On	page 29

Changing the number of rings

You can change the number of times the phone rings before the unit answers calls. You can select 2 to 7 rings, or "Auto". "Auto": The unit answers after 2 rings when new messages have been recorded, and after 5 rings when there are no new messages. If you call your phone from outside to listen to new messages (page 28), you will know that there are no new messages when the phone rings for the 3rd time. You can then hang up without being charged for the call.

- 1 [≡/OK] → "Answer System" → [▶]
- 2 "Settings" → [▶]
- 3 "Number of Rings" → [▶]
- 4 Select the desired setting. → [▶] → [↻⊙]

For voice mail service subscribers

Please note the following:

- To receive messages correctly with your voice mail service, we recommend that

you do not use the unit's answering system. Make sure that the answering system is turned off (page 25).

- If you would rather use the unit's answering system than the voice mail service provided by your service provider/telephone company, ask your service provider/telephone company to deactivate your voice mail service. If your service provider/telephone company cannot do this, set this unit's "Number of Rings" setting so that this unit's answering system answers calls before your service provider/telephone company's voice mail service tries to answer your calls. It is necessary to check the number of rings required to activate the voice mail service provided by your service provider/telephone company before changing this setting.

Selecting the caller's recording time

You can change the maximum message recording time allotted to each caller, or set the unit to greet callers but not record messages.

- 1 [≡/OK] → "Answer System" → [▶]
- 2 "Settings" → [▶]
- 3 "Recording Time" → [▶]
- 4 Select the desired setting. → [▶] → [↻⊙]

Turning call screening on/off

While a caller is leaving a message, you can screen the call through the handset speaker.

- 1 [≡/OK] → "Answer System" → [▶]
- 2 "Settings" → [▶]
- 3 "Call Screening" → [▶]
- 4 "On" or "Off" → [▶] → [↻⊙]

Multi-unit Operation

Operating additional units

Additional handsets

Up to 6 handsets can be registered to the base unit.

Important:

- The additional handset model recommended for use with this unit is noted on page 6. If other model handset is used, certain operations (handset settings, base unit settings, etc.) may not be available.
- Additional handsets will give you the freedom to, for example, have an intercom call with another handset while a third handset is on an outside call.

Registering a handset to the base unit

The included handset and base unit are preregistered. If for some reason the handset is not registered to the base unit (for example, Ψ flashes even when the handset is near the base unit), register the handset manually (page 30).

To register an additional handset to the base unit (easy registration)

After purchasing an additional handset, register it to the base unit. Ensure that the additional handset is switched on. If it is not on, press and hold **[Ψ]** for few seconds to turn the handset on.

- 1 Lift the additional handset and press **[Ψ]** to put the handset in standby mode.
- 2 Press and hold **[Ψ]** on the base unit for about 3 seconds, until the registration tone sounds.

- 3 Place the additional handset on the base unit. The registration tone continues to sound. With the handset still on the base unit, wait until a confirmation tone sounds and Ψ stops flashing.

Note:

- If an error tone sounds, or if Ψ is still flashing, register the handset manually (manual registration; page 30).
- If all registered handsets start ringing in step 2, press **[Ψ]** to stop. Start again from step 1.
- Charge the batteries of your additional handset for about 7 hours before initial use.
- This registration method cannot be used for handsets that have already been registered to the base unit. Register the handset manually (manual registration; page 30).

To register a handset to the base unit (manual registration)

You can register a handset to the base unit manually using the following method.

- 1 **[Ψ /OK]** \rightarrow "Handset Setup" \rightarrow **[\triangleright]**
- 2 "Registration" \rightarrow **[\triangleright]**
- 3 "Register H.set" \rightarrow **[\triangleright]**
- 4 Press and hold **[Ψ]** on the base unit for about 3 seconds, until the registration tone sounds.
 - If all registered handsets start ringing, press **[Ψ]** to stop, then repeat this step.
 - After pressing **[Ψ]**, the rest of this procedure must be completed within 1 minute.
- 5 Wait until "Enter Base PIN" is displayed, then enter the base unit PIN (default: "0000"), then press **[Ψ /OK]**.
 - When the handset has been registered successfully, Ψ will stop

Multi-unit Operation

flashing. If keytones are turned on (page 19), a confirmation tone will be heard.

Cancelling a handset

A maximum of 6 handsets can be registered to the base unit. A handset can cancel its own registration (or the registration of another handset) that is stored in the base unit. This will allow the base unit to "forget" the handset.

- 1 **[/OK]** → "Base Unit Setup" → **[▶]**
- 2 Enter "335".
- 3 **"Cancel Handset"** → **[▶]**
 - The numbers of all handsets registered to the base unit are displayed.
- 4 Select the handset(s) you want to cancel, by pressing the desired handset number.
 - The selected handset number(s) will flash.
 - To cancel a selected handset number, press the number again. The number will stop flashing.
- 5 **[/OK]** → **"Yes"** → **[▶]**
 - A long beep will sound as each handset number disappears.
 - The handset does not beep when cancelling its own registration.
- 6 **[]**

Increasing the range of the base unit

You can increase the signal range of the base unit by using a DECT repeater. Please use only the Panasonic DECT repeater noted on page 5. Consult your Panasonic dealer for details.

Important:

- Before registering the repeater to this base unit, you must turn the repeater mode on.
- Do not use more than one repeater at a time.

Setting the repeater mode

- 1 **[/OK]** → "Base Unit Setup" → **[▶]**
- 2 **"Other Options"** → **[▶]**
- 3 **"Repeater Mode"** → **[▶]**
- 4 **"On"** or **"Off"** → **[▶]** → **[]**

Note:

- After turning repeater mode on or off, will flash on the handset momentarily. This is normal. The handset can be used once stops flashing.

Intercom between handsets

Intercom calls can be made between handsets.

Example: When handset 1 calls handset 2

- 1 **Handset 1:**
[INT] → Press **[2]** (desired handset number).
- 2 **Handset 2:**
Press **[]** / **[]** to answer.
- 3 When finished talking, press **[]**.

Transferring calls between handsets

Outside calls can be transferred between 2 people.

Multi-unit Operation

Example: When handset 1 transfers a call to handset 2

- 1 Handset 1:**
During an outside call, press **[INT]**. → Press **[2]** (desired handset number).
 - The outside call will be put on hold.
 - If there is no answer, press **[INT]** to return to the outside call.
- 2 Handset 2:**
Press **[📞]** / **[📞]** to answer the page.
 - Handset 2 can talk with handset 1.
- 3 Handset 1:**
To complete the call transfer, press **[📞]**.

Transferring a call without speaking to the other handset user

- 1** During an outside call, press **[INT]**. → Press the desired handset number.
 - 📞 flashes to indicate the outside call is on hold.
- 2 [📞]**
 - The outside call rings at the other handset.

Note:

- If the other handset user does not answer the call within 1 minute, the call will ring at your handset again.

Conference calls

2 people can have a conference call with an outside party.

Example: When handset 1 transfers a call to handset 2

- 1 Handset 1:**
During an outside call, press **[INT]**. → Press **[2]** (desired handset number).
 - The outside call will be put on hold.
 - If there is no answer, press **[INT]** to return to the outside call.

- 2 Handset 2:**
Press **[📞]** / **[📞]** to answer the page.
 - Handset 2 can talk with handset 1.
- 3 Handset 1:**
To establish a conference call, press **[3]**.

Copying phonebook entries

You can copy handset phonebook entries to the handset phonebook of another compatible Panasonic handset.

Copying one entry

- 1** Find the desired handset phonebook entry (page 17). → **[📞/OK]**
- 2** “Copy” → **[▶]**
- 3** Enter the handset number you wish to send the handset phonebook entry to.
 - When an entry has been copied, “Completed” is displayed.
 - To continue copying another entry: “Yes” → **[▶]** → Find the desired handset phonebook entry. → **[▶]**
- 4** **[📞]**

Copying all entries

- 1** **[📞]** → **[📞/OK]**
- 2** “Copy All” → **[▶]**
- 3** Enter the handset number you wish to send the handset phonebook entry to.
 - When all entries have been copied, “Completed” is displayed.
- 4** **[📞]**

Useful Information

Using the belt clip

Attaching the belt clip

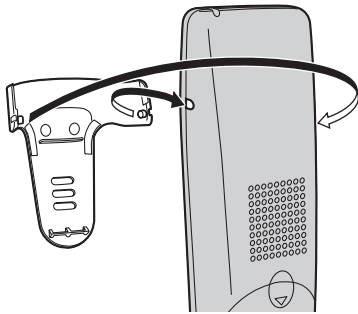

Removing the belt clip

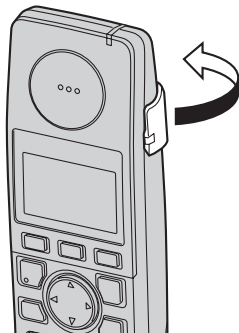

- The pictured model is KX-TG7160.

Using the shoulder rest attachment

The shoulder rest attachment allows hands-free phone conversations.

Attaching the shoulder rest attachment

Attach the included belt clip to the handset beforehand (page 33). Slide the shoulder rest attachment to the belt clip until it clicks.

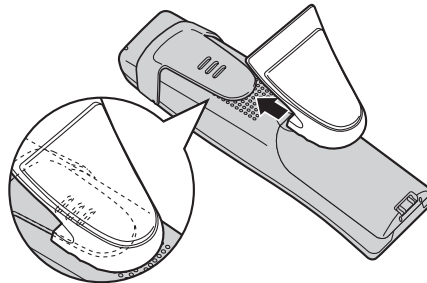

Note:

- If the base unit is mounted on a wall, remove the shoulder rest attachment before charging the handset.

Removing the shoulder rest attachment

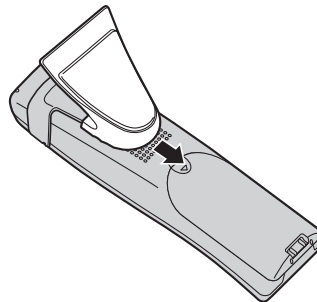

Useful Information

Character entry

The dial keys are used to enter characters and numbers. Each dial key has multiple characters assigned to it. The available character entry modes are Alphabet (ABC), Numeric (0-9), Greek (ΑΒΓ), Extended 1 (ÄÅ), Extended 2 (ŠŠ), and Cyrillic (АБВ). When in these entry modes except Numeric, you can select which character is entered by pressing a dial key repeatedly.

- Press [◀] or [▶] to move the cursor.
- Press dial keys to enter characters and numbers.
- Press [C/✕] to erase the character or number highlighted by the cursor. Press and hold [C/✕] to erase all characters or numbers.
- Press [✕] to switch between uppercase and lowercase.
- To enter another character located on the same dial key, press [▶] to move the cursor to the next space, then press the appropriate dial key.

Character entry modes

Several character entry modes can be used when entering text. The characters that can be entered depend on the entry mode.

Characters available in each character entry mode

When the unit displays the character entry screen:

[□] → Select a character entry mode. → [▶]

Alphabet character table (ABC)

0	1	ABC 2	DEF 3	GHI 4	JKL 5	MNO 6	PQRS 7	TUV 8	WXYZ 9
Space # 0	Space # & ' () * , - . / 1	A B C 2	D E F 3	G H I 4	J K L 5	M N O 6	P Q R S 7	T U V 8	W X Y Z 9
		a b c 2	d e f 3	g h i 4	j k l 5	m n o 6	p q r s 7	t u v 8	w x y z 9

Numeric entry table (0-9)

0	1	ABC 2	DEF 3	GHI 4	JKL 5	MNO 6	PQRS 7	TUV 8	WXYZ 9
0	1	2	3	4	5	6	7	8	9

Greek character table (ΑΒΓ)

0	1	ABC 2	DEF 3	GHI 4	JKL 5	MNO 6	PQRS 7	TUV 8	WXYZ 9
Space # 0	Space # & ' () * , - . / 1	A B Γ 2	Δ E Z 3	H Θ I 4	K Λ M 5	N Ξ O 6	Π Ρ Σ 7	T Υ Φ 8	X Ψ Ω Ξ 9

Useful Information

Extended 1 character table (AÄÅ)

0	1	ABC2	DEF3	GHI4	JKL5	MNO6	PQRS7	TUV8	WXYZ9
Space 0	Space # & ' () * , - . / 1	A À Á Â Ã Ä Å Æ B C Ç 2	D E È É Ê Ë Ë F 3	G Ğ H I Ì Í Î Ï 4	J K L 5	M N Ñ O Ò Ó Ô Ö Ø ø 6	P Q R S \$ ß 7	T U Û Ú Ü Ü Û V 8	W Ŵ X Y ý Z 9
		a à á â ã ä å æ b c ç 2	d e è é ê ë ë f 3	g ğ h i ì í î ï 4	j k l 5	m n ñ o ò ó ô ö ø ø 6	p q r s \$ ß 7	t u ù ú û ü ü v 8	w ŵ x y ý z 9

- The following are used for both uppercase and lowercase: ø Ş Ŵ ŷ

Extended 2 character table (ŠŠš)

0	1	ABC2	DEF3	GHI4	JKL5	MNO6	PQRS7	TUV8	WXYZ9
Space 0	Space # & ' () * , - . / 1	A Á Ā Ā B C Ā Ć 2	D Ď E É Ě ě Ě F 3	G H I Í 4	J K L Ł Ł Ł 5	M N Ń Ń O Ó Ō Ő 6	P Q R Ŕ Ŕ Š Š Š 7	T Ť U Ú Ú Ů ú v 8	W X Y ŷ Ý Z Ž ž Ž 9
		a á ā Ā b c Ā Ć 2	d ě e é ě ě ě f 3	g h i í 4	j k l Ł Ł Ł 5	m n Ń Ń o ó ō ő 6	p q r Ŕ Ŕ š š š 7	t ť u Ů ú ů ů v 8	w x y ŷ ý z ž ž ž 9

- The following are used for both uppercase and lowercase:

Ą Ć Ć Ę Ł Ł Ł Ń Ŕ Š Š Ů ŷ Ž Ž Ž

Cyrillic character table (АБВ)

0	1	ABC2	DEF3	GHI4	JKL5	MNO6	PQRS7	TUV8	WXYZ9
Space 0 Г Ё І ї ŷ	Space # & ' () * , - . / 1	А Б В Г 3 2	Д Е Ж З 3 3	И Й К Л 4 4	М Н О У 5 5	Р С Т У 6 6	Ф Х Ц Ч 7 7	Ш Щ Ъ Ы 8 8	Ь Э Ю Я 9 9

Useful Information

Error messages

Error message	Cause & solution
Answer Sys. Full	<ul style="list-style-type: none"> • Erase unnecessary messages (page 26).
Error	<ul style="list-style-type: none"> • Recording was too short. Try again.
Failed	<ul style="list-style-type: none"> • Phonebook copy failed. Confirm the other handset (the receiver) is in standby mode and try again.
Incomplete	<ul style="list-style-type: none"> • The receiver's phonebook memory is full. Erase the unnecessary phonebook entries from the other handset (the receiver) and try again.
Memory Full	<ul style="list-style-type: none"> • The handset's phonebook memory is full. Erase unnecessary entries (page 17). • Message memory is full. Erase unnecessary messages (page 26).
You must first subscribe to Caller ID.	<ul style="list-style-type: none"> • You must subscribe to Caller ID service. Once you receive caller information after subscribing to Caller ID service, this message will not be displayed.

Troubleshooting

If you still have difficulties after following the instructions in this section, disconnect the AC adaptor and turn off the handset, then reconnect the AC adaptor and turn on the handset.

Telephone

Problem	Cause & solution
<p>⚡ is flashing.</p>	<ul style="list-style-type: none"> • The handset is not registered to the base unit. Register it (page 30). • The handset is too far from the base unit. Move closer. • The AC adaptor is not connected. Check the connections. • You are using the handset or base unit in an area with high electrical interference. Place the handset and base unit away from interference sources, such as antennas and mobile phones.
<p>The handset display is blank.</p>	<ul style="list-style-type: none"> • The handset is not turned on. Turn the power on (page 13).

Useful Information

Problem	Cause & solution
The handset will not turn on.	<ul style="list-style-type: none"> ● Make sure that the batteries are installed correctly (page 11). ● Fully charge the batteries (page 12). ● Clean the charge contacts and charge again (page 12).
I have changed the display language to a language I cannot read.	<ul style="list-style-type: none"> ● Change the display language (page 13).
I cannot make or receive calls.	<ul style="list-style-type: none"> ● The AC adaptor or telephone line cord is not connected. Check the connections. ● If you are using a splitter to connect the unit, remove the splitter and connect the unit to the wall socket directly. If the unit operates properly, check the splitter. ● Disconnect the base unit from the telephone line and connect the line to a known working telephone. If the working telephone operates properly, contact our service personnel to have the unit repaired. If the working telephone does not operate properly, contact your service provider/telephone company.
The unit does not ring.	<ul style="list-style-type: none"> ● The ringer volume is turned off. Adjust the ringer volume (page 19, 22).
The batteries should be charging but the battery icon does not change.	<ul style="list-style-type: none"> ● Clean the charge contacts and charge again (page 12).
A busy tone is heard when [📞] is pressed.	<ul style="list-style-type: none"> ● The handset is too far from the base unit. Move closer and try again. ● Another handset is in use or the answering system is being used. Wait and try again later.
Static is heard, sound cuts in and out. Interference from other electrical units.	<ul style="list-style-type: none"> ● Place the handset and the base unit away from other electrical appliances. ● Move closer to the base unit. ● Your unit is connected to a telephone line with DSL service. We recommend connecting a filter (contact your DSL service provider) to the telephone line between the base unit and the telephone line jack.
Noise is heard during a call.	<ul style="list-style-type: none"> ● You are using the handset or base unit in an area with high electrical interference. Place the handset and base unit away from interference sources, such as antennas and mobile phones.
The handset/base unit stops working while being used.	<ul style="list-style-type: none"> ● Disconnect the AC adaptor and turn off the handset. Reconnect the AC adaptor, then turn on the handset and try again.

Useful Information

Problem	Cause & solution
Pressing [●] does not display/dial the last number dialled.	<ul style="list-style-type: none"> • The redialled number was more than 24 digits long. Redial the number manually.
The handset beeps intermittently and/or [] flashes.	<ul style="list-style-type: none"> • Fully charge the batteries (page 12).
I fully charged the batteries, but [] still flashes.	<ul style="list-style-type: none"> • Clean the charge contacts and charge again (page 12). • It is time to replace the batteries (page 11).
I fully charged the batteries, but the operating time seems to be short.	<ul style="list-style-type: none"> • Wipe the battery ends (⊕, ⊖) and the unit contacts with a dry cloth.
Caller information is not displayed.	<ul style="list-style-type: none"> • You need to subscribe to Caller ID service. Consult your service provider/telephone company for details. • Your unit is connected to a telephone line with DSL service. We recommend connecting a filter (contact your DSL service provider) to the telephone line between the base unit and the telephone line jack.
The handset does not announce the displayed phone number.	<ul style="list-style-type: none"> • The handset ringer volume is turned off. Adjust it (page 19). • The voice announce feature is turned off. Turn it on (page 14). • While you are on an outside call, the handset does not announce phonebook information when searching the phonebook.
While viewing caller information, the display returns to standby mode.	<ul style="list-style-type: none"> • Do not pause for over 1 minute while searching.
I cannot register a handset to the base unit.	<ul style="list-style-type: none"> • The maximum number of handsets (6) are already registered to the base unit. Cancel unused handset registrations from the base unit (page 31). • You entered the wrong PIN number. If you forget your PIN, consult your nearest Panasonic service centre. • Place the handset and the base unit away from other electrical appliances.

Useful Information**Answering system**

Problem	Cause & solution
The unit does not record new messages.	<ul style="list-style-type: none"> • The answering system is turned off. Turn it on (page 25). • The recording time is set to "Greeting Only". Select "1 Minute" or "3 Minutes" (page 29). • If you subscribe to the voice mail service, messages are recorded by your service provider/telephone company not your telephone. Change the unit's "Number of Rings" setting so that the unit's answering system can answer the call before the voice mail service or consult your service provider/telephone company (page 29).
The other party complains that they cannot leave a message.	<ul style="list-style-type: none"> • The recording time is set to "Greeting Only". Select "1 Minute" or "3 Minutes" (page 29).
I cannot operate the answering system with the handset.	<ul style="list-style-type: none"> • The base unit or another handset is being used. Wait for the other user to finish. • A caller is leaving a message. Wait for the caller to finish. • The handset is too far from the base unit. Move closer.
When I try to operate the answering system with the base unit, the answer on indicator flashes for a few seconds and I cannot operate the answering system.	<ul style="list-style-type: none"> • Another handset is being used. Wait for the other user to finish. • A caller is leaving a message. Wait for the caller to finish.
I cannot operate the answering system remotely.	<ul style="list-style-type: none"> • You are entering the wrong remote access code. If you forget the remote access code, store a new remote access code and try again (page 27). • You are pressing the dial keys too quickly. Press each key firmly. • The answering system is turned off. Turn it on (page 28). • You are using a pulse telephone. Try again using a touch tone phone.
While recording a greeting message or listening to messages, the unit rings and recording stops.	<ul style="list-style-type: none"> • A call is being received. Answer the call and try again later.

Useful Information

Specifications

■ **Standard:**

DECT (Digital Enhanced Cordless Telecommunications),
GAP (Generic Access Profile)

■ **Number of channels:**

120 Duplex Channels

■ **Frequency range:**

1.88 GHz to 1.90 GHz

■ **Duplex procedure:**

TDMA (Time Division Multiple Access)

■ **Channel spacing:**

1,728 kHz

■ **Bit rate:**

1,152 kbit/s

■ **Modulation:**

GFSK (Gaussian Frequency Shift Keying)

■ **RF transmission power:**

Approx. 250 mW

■ **Voice coding:**

ADPCM 32 kbit/s

■ **Power source:**

220–240 V, 50 Hz

■ **Power consumption, Base unit:**

Standby: Approx. 1.9 W

Maximum: Approx. 6.8 W

■ **Operating conditions:**

5 °C–40 °C, 20 %–80 % relative air humidity
(dry)

■ **Dimensions:**

Base unit: Approx. 60 mm × 173 mm × 105 mm

Handset (KX-TG7160): Approx. 179 mm × 48 mm × 34 mm

Handset (KX-TG7180): Approx. 179 mm × 48 mm × 38 mm

■ **Mass (weight):**

Base unit: Approx. 260 g

Handset (KX-TG7160): Approx. 154 g

Handset (KX-TG7180): Approx. 164 g

Note:

- Specifications are subject to change.
- The illustrations used in these operating instructions may differ slightly from the actual product.

Useful Information

Conditions of guarantee

This guarantee is in addition to and does not in any way affect any statutory or other rights of consumer purchasers. If within the applicable guarantee period, the appliance proves to be defective by reason of faulty design, workmanship or materials, we undertake subject to the following conditions to have the defective appliance (or any part or parts there of) repaired or replaced free of charge.

1. The appliance shall have been purchased and used solely within either the UK or ROI and in accordance with standard operating instructions and the technical and/or Safety Standards required in the UK.
2. The appliance should be returned together with this guarantee and proof of date of purchase promptly on being found defective at the purchaser's risk and expense to the authorised dealer from whom the appliance was purchased or to the nearest authorised dealer. All enquires must be through such dealers.
3. This guarantee shall not apply to damage caused through fire, accident, lightning, misuse, wear and tear, neglect, incorrect adjustment or repair, to damage caused through installation, adaption, modification or use in an improper manner or inconsistent with the technical and/or safety standards required in the country where this appliance is used, or to damage occurred during transit to or from the purchaser.
4. If at any time during the guarantee period any part or parts of the appliance are replaced with a part or parts not supplied or approved by us or of an objective quality safe and suitable for the appliance, or the appliance has been dismantled or repaired by any person not authorised by us, we shall have the right to terminate this guarantee in whole or in part immediately without further notice.
5. The purchaser's sole and exclusive remedy under this guarantee against us is for the repair or replacement of the appliance or any defective part or parts and no other remedy, including, but not limited to, incidental or consequential damage or loss of whatsoever nature shall be available to the purchaser.
6. This guarantee shall not apply to batteries and any other items of limited natural life.
7. Our decision on all matters relating to complaints shall be final. Any appliance or defective part which has been replaced shall become our property.
8. The guarantee period applicable to this product shall be 12 months.

Please keep these operating instructions with your receipt.

Panasonic Business Systems U.K.

Receipt No. _____	Date of purchase _____
Model No. _____	Serial No. _____

Index

Index

- A**
 - Additional handsets: 30
 - Alarm: 21
 - Answering calls: 16
 - Answering system: 25
 - Listening to messages: 26
 - Remote operation: 27
 - Turning on/off: 25
 - Auto talk: 16, 19
- B**
 - Base unit
 - Settings: 22
 - Battery
 - Charge: 12
 - Installation: 11
 - Performance: 12
 - Replacement: 11
 - Strength: 12
 - Belt clip: 4, 33
 - Bone conduction earpiece: 8
- C**
 - Caller ID service: 23
 - Call waiting: 15
 - Chain dial: 18
 - Character entry: 34
 - Conference calls: 32
 - Connections: 11
 - Copy
 - Phonebook: 32
- D**
 - Date and time: 13
 - Display
 - Contrast: 19
 - Icons: 10
 - Language: 13
 - Standby mode: 19
- H**
 - Handset
 - Cancelling: 31
 - Locator: 16
 - Power on/off: 13
 - Registration: 30
 - Settings: 19
- I**
 - Intercom: 31
- K**
 - Keytones: 19
- M**
 - Making calls: 15
 - Message alert: 19
 - Missed calls: 23
- Mute:** 15
- P**
 - Pause: 15
 - Phonebook
 - Handset phonebook: 17
 - Phonebook copy: 32
 - PIN
 - Base unit: 22
 - Power on/off: 13
- R**
 - Recall: 15, 22
 - Recording
 - Greeting message: 25
 - Redialling: 15
 - Redial list: 15
 - Registration: 30
 - Repeater: 31
 - Ringtones: 19
- S**
 - Shoulder rest attachment: 4, 33
 - Speakerphone: 15
- T**
 - Transfer calls: 31
- V**
 - Voice announce: 14
 - Voice mail: 24
 - Volume
 - Receiver: 15
 - Ringer (Base unit): 22
 - Ringer (Handset): 19
 - Speakerphone: 15

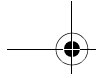

Notes

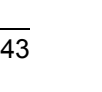
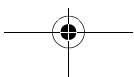
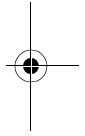
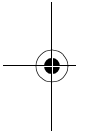

Sales and support information

Customer Care Centre

- For customers within the UK: 08700 100 076
- For customers within the Republic of Ireland: 01289 8333
- Visit our website for product information: www.panasonic.co.uk
- E-mail: customer.care@panasonic.co.uk

Direct Sales at Panasonic UK

- Order accessory and consumable items for your product with ease and confidence by phoning our Customer Care Centre Monday - Thursday 9:00am - 5:30pm, Friday 9:30am - 5:30pm (Excluding public holidays).
- Or go on line through our Internet Accessory ordering application at www.panasonic.co.uk
- Most major credit and debit cards accepted.
- All enquiries transactions and distribution facilities are provided directly by Panasonic UK Ltd.
- It couldn't be simpler!
- Also available through our Internet is direct shopping for a wide range of finished products, take a browse on our website for further details.

Customer Care Helpline Tel. No.: U.K. 08700 100 076 / R.O.I. 01289 8333

CE0470

1999/5/EC

Sales Department:

Panasonic Business Systems U.K.

Panasonic House, Willoughby Road, Bracknell, Berkshire, RG12 8FP

Panasonic Communications Zhuhai Co., Ltd.

3 Ping Xi 8 Lu, Nanping Keji Gongye Yuan, Zhuhai, Guangdong, China 519060

Copyright:

This material is copyrighted by Panasonic Communications Co., Ltd., and may be reproduced for internal use only. All other reproduction, in whole or in part, is prohibited without the written consent of Panasonic Communications Co., Ltd.

© 2006 Panasonic Communications Co., Ltd. All Rights Reserved.



TG7160E

PQQX15393ZA CC0806PM0