



# Panasonic®

## Operating Instructions Plasma Television

Model No. **TH-42PY800P**  
**TH-50PY800P**

# VIERA

VIERA  
Link



AVCHD™

DOLBY  
DIGITAL

SRS  
TruSurround XT

SD  
HG

FULL  
HD  
1920×1080p

HD  
ready  
1080p

HDMI™  
HIGH-DEFINITION MULTIMEDIA INTERFACE

Please read these instructions before operating your set and retain them for future reference.

The images shown in this manual are for illustrative purposes only.

Please refer to Pan European Guarantee Card if you need to contact your local Panasonic dealer for assistance.

English



TQB0E0604U

Turn your own living room into a movie theatre!

**Experience an amazing level of multi-**



# media excitement

## Enjoy rich multi-media

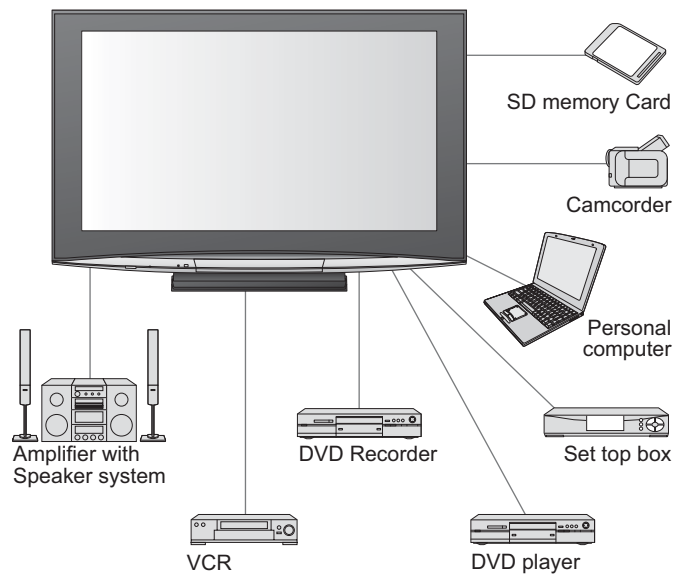

### Up to 100,000 hours Plasma Panel Lifetime

The Plasma display panel used in the 2008 VIERA TV range is rated for up to 100,000 hours.\*

\*This measurement is based on the time taken for the brightness of the panel to reduce to half of its maximum level. The time taken to reach this level may vary depending on the image content and the environment where the TV is used. Image retention and malfunctions are not taken into account.

# Contents

## Be Sure to Read

- Safety Precautions ..... 4  
(Warning / Caution)
- Notes ..... 5
- Maintenance ..... 5

## Quick Start Guide

- Accessories / Options ..... 6
- Identifying Controls ..... 9
- Basic Connection ..... 10
- Auto Setup ..... 12

## Enjoy your TV!

### Basic Features

- Watching TV ..... 14
- Viewing Teletext ..... 16
- Watching Videos and DVDs ..... 18

### Advanced Features

- How to Use Menu Functions ..... 20  
(picture, sound quality, etc.)
- Editing Programmes ..... 24
- Tuning Programmes ..... 26
- Control Programme Audience ..... 28
- Restore Settings ..... 29
- Input Labels ..... 30
- Displaying PC Screen on TV ..... 31
- Viewing from SD Card ..... 32  
(Photos and Movies)
- Link Functions ..... 34  
(Q-Link / VIERA Link)
- External Equipment ..... 40

### FAQs, etc.

- Technical Information ..... 42
- FAQs ..... 45
- Specifications ..... 47
- Licence ..... 48

# Safety Precautions

## Warning

### Handling the mains plug and lead

- Insert the mains plug fully into the socket outlet. (If the mains plug is loose, it could generate heat and cause fire.)
- Ensure that the mains plug is easily accessible.
- Ensure the earth pin on the mains plug is securely connected to prevent electrical shock.
  - An apparatus with CLASS I construction shall be connected to a mains socket outlet with a protective earthing connection.
- Do not touch the mains plug with a wet hand. (This may cause electrical shock.)
- Do not use any mains lead other than that provided with this TV. (This may cause fire or electrical shock.)
- Do not damage the mains lead. (A damaged lead may cause fire or electrical shock.)
  - Do not move the TV with the lead plugged in the socket outlet.
  - Do not place a heavy object on the lead or place the lead near a high-temperature object.
  - Do not twist the lead, bend it excessively, or stretch it.
  - Do not pull on the lead. Hold onto the mains plug body when disconnecting lead.
  - Do not use a damaged mains plug or socket outlet.

If you find any abnormality, remove the mains plug immediately!

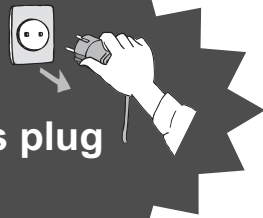

AC 220-240 V  
50 / 60 Hz



### Power source

- This TV is designed to operate on 220-240 V, 50 / 60 Hz AC.

### Do not remove covers NEVER modify the TV yourself

(High-voltage components may cause serious electrical shock.)

- Have the TV checked, adjusted, or repaired at your local Panasonic dealer.

### Keep liquids away from the TV

- To prevent damage which may result in fire or shock hazard, do not expose this appliance to dripping or splashing.
- Do not place containers with water (flower vase, cups, cosmetics, etc.) above the TV. (including on shelves above, etc.)

### Do not expose to direct sunlight and other sources of heat

- Avoid exposing the TV to direct sunlight and other sources of heat. To prevent fire never place any type of candle or naked flame on top or near the TV.

### Do not place foreign objects inside the TV

- Do not allow any objects to drop into the TV through the air vents (fire or electrical shock may result).

### Do not place the TV on sloped or unstable surfaces

- The TV may fall off or tip over.

### Use only the dedicated pedestals / mounting equipment

- Using an unapproved pedestal or other fixtures may make the TV unstable, risking injury. Be sure to ask your local Panasonic dealer to perform setup.
- Use approved pedestals / mounts (p. 6).

### Do not allow children to handle SD Card

- As with a small object, SD Card can be swallowed by young children. Please remove SD Card immediately after use.

# Notes

## Caution

### ■ When cleaning the TV, remove the mains plug

- Cleaning an energized TV may cause electrical shock.

### ■ When the TV is not going to be used for a long period of time, remove the mains plug

- This TV will still consume some power even in the Off mode, as long as the mains plug is still connected to a live socket outlet.

### ■ Transport only in upright position

- Transporting the TV with its display panel facing upright or downward may cause damage to the internal circuitry.

### ■ Allow sufficient space around the TV for radiated heat

Minimum distance

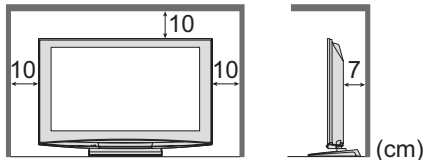

- When using the pedestal, keep the space between the bottom of the TV and the floor surface.
- In case of using Wall-hanging bracket, follow the manual of it.

### ■ Do not block the rear air vents

- Blocked ventilation by newspapers, table cloths, curtains, etc. may cause overheating, fire or electrical shock.

### ■ Do not expose your ears to excessive volume from the headphones

- Irreversible damage can be caused.

### Do not display a still picture for a long time

This causes the image to remain on the plasma screen ("image retention"). This is not considered a malfunction and is not covered by the warranty.

Typical still images

- Programme number and other logos
- Image displayed in 4:3 mode
- Video game
- Computer image



To prevent image retention, contrast is lowered automatically after a few minutes if no signals are sent or no operations are performed. (p. 45)

### ■ Auto power standby function

- If no signal is received and no operation is performed in TV mode for 30 minutes, the TV will automatically go to standby mode.

### ■ Keep the TV away from these types of equipment

- Electronic equipment  
In particular, do not place video equipment near the TV (electromagnetic interference may distort images / sound).
- Equipment with an infrared sensor  
This TV also emits infrared rays (this may affect operation of other equipment).

# Maintenance

First, remove the mains plug from the socket outlet.

## Display panel

Regular care: Gently wipe the surface clean of dirt by using a soft cloth.

Major contamination: Wipe the surface clean using a soft cloth dampened with clean water or diluted neutral detergent (1 part detergent to 100 parts water). Then, using a soft dry cloth, evenly wipe the surface clean until it is dry.

### Caution

- The surface of the display panel has been specially treated and may be easily damaged. Do not tap or scratch the surface with your fingernail or other hard object.
- Take care not to subject the surface to insect repellent, solvent, thinner, or other volatile substances (this may degrade surface quality).

## Cabinet, Pedestal

Regular care: Wipe the surface clean using a soft dry cloth.

Major contamination: Dampen a soft cloth with clean water or water containing a small amount of neutral detergent. Then, wring the cloth and wipe the surface clean with it. Finally, wipe the surface clean with a dry cloth.

### Caution

- Take care not to subject the TV's surfaces to detergent. (A liquid inside the TV could lead to product failure.)
- Take care not to subject surfaces to insect repellent, solvent, thinner, or other volatile substances (this may deteriorate the surface by peeling the paint).
- Do not allow the cabinet and pedestal to make contact with a rubber or PVC substance for a long time.

## Mains plug

Wipe the mains plug with a dry cloth at regular intervals. (Moisture and dust may lead to fire or electrical shock.)

# Accessories / Options

## Standard accessories

- Remote Control  
● N2QAYB000240



Check that you have the accessories and items shown

- Batteries for the Remote Control (2)  
● R6 (UM3)



- Clamper (2)  
➔ p. 8

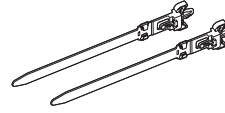

- Mains Lead  
➔ p. 11

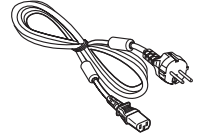

- Operating Instructions

- Cleaning cloth



- Pedestal  
➔ p. 7

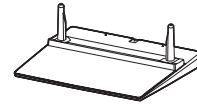

- Pan European Guarantee Card

- This product contains possibly dangerous parts (such as plastic bags), that can be breathed in or swallowed by young children accidentally. Keep these parts out of reach of young children.

## Optional accessories

Plasma TV stand

- TY-S42PZ800W (TH-42PY800P)
- TY-S50PZ800W (TH-50PY800P)

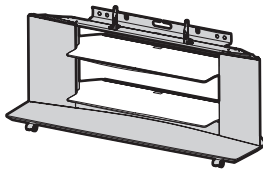

Wall-hanging bracket (vertical)

- TY-WK42PV4W

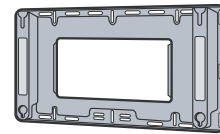

(angle)

- TY-WK42PR4W

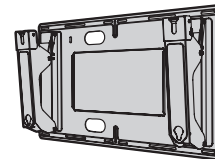

### Caution

- In order to maintain the unit's performance and safety, be absolutely sure to ask your dealer or a licenced contractor to secure the wall-hanging brackets.
- Carefully read the instructions accompanying the plasma TV stand or pedestal, and be absolutely sure to take steps to prevent the TV from tipping over.
- Handle the TV carefully during installation since subjecting it to impact or other forces may cause product damage.

## Installing remote's batteries

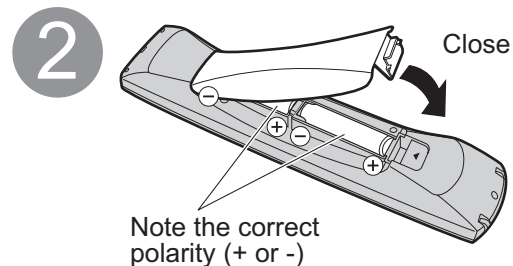
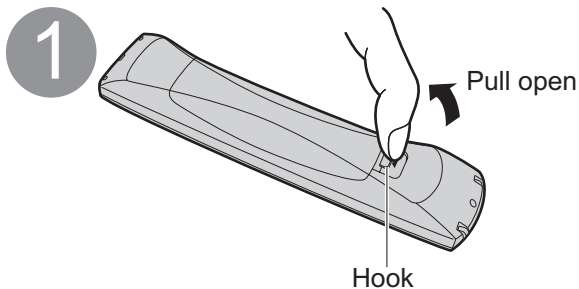

### Caution

- Incorrect installation may cause battery leakage and corrosion, resulting in damage to the remote control.
  - Do not mix old and new batteries.
  - Do not mix different battery types (such as alkaline and manganese batteries).
  - Do not use rechargeable (Ni-Cd) batteries.
  - Do not burn or breakup batteries.
- Batteries must not be exposed to excessive heat such as sunshine, fire or the like.

## Attaching the pedestal

### Warning

#### Do not disassemble or modify the pedestal.

- Otherwise the TV may fall over and become damaged, and personal injury may result.

### Caution

#### Do not use any other TV and displays.

- Otherwise the TV may fall over and become damaged, and personal injury may result.

#### Do not use the pedestal if it becomes warped or physically damaged.

- If you use the pedestal while it is physically damaged, personal injury may result. Contact your nearest Panasonic dealer immediately.

#### During set-up, make sure that all screws are securely tightened.

- If insufficient care is taken to ensure screws are properly tightened during assembly, the pedestal will not be strong enough to support the TV, and it might fall over and become damaged, and personal injury may result.

#### Ensure that the TV does not fall over.

- If the TV is knocked or children climb onto the pedestal with the TV installed, the TV may fall over and personal injury may result.

#### Two or more people are required to install and remove the TV.

- If two or more people are not present, the TV may be dropped, and personal injury may result.

- Ⓐ Assembly screw (4)  
(silver)  
● XYN5+F18FN

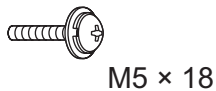

- Ⓑ Assembly screw (4)  
(black)  
● THEL060N



- Ⓒ Pole (2)  
● R: TBLA3614  
● L: TBLA3615

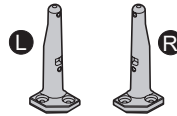

- Ⓓ Base  
● TBLX0039 (TH-42PY800P)  
● TBLX0042 (TH-50PY800P)

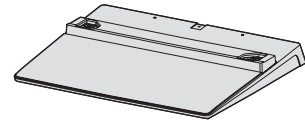

### Assembling the pedestal

Use the four assembly screws (A) to fasten the left and right poles to the base securely.

- Make sure that the screws are securely tightened.
- Forcing the assembly screws the wrong way will strip the threads.
- "L" or "R" mark is stamped on the bottom of the pole.

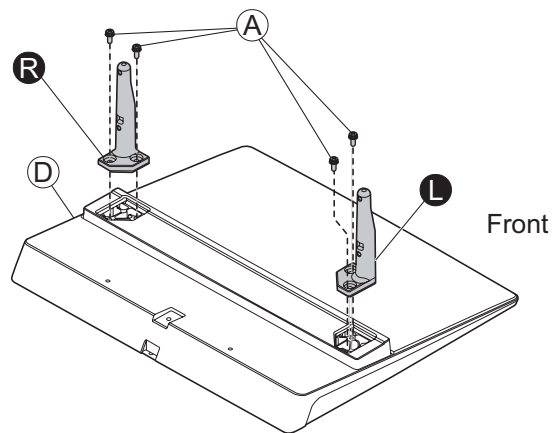

### Securing the TV

Use the assembly screws (B) to fasten securely.

- Make sure that the screws are securely tightened.
- Carry out the work on a horizontal and level surface.

View from the bottom

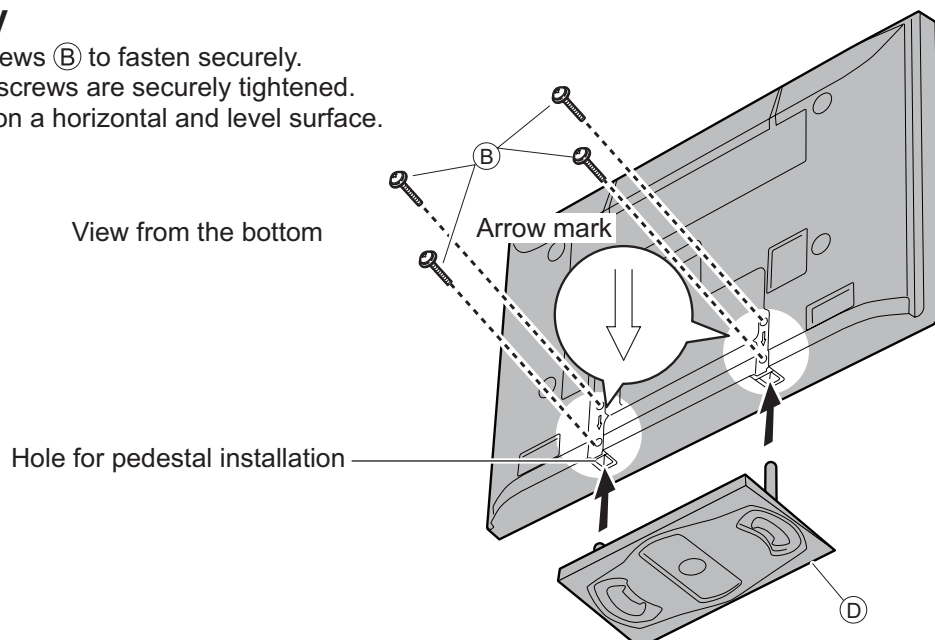

# Accessories / Options

## Using the clammer

Rear of the TV

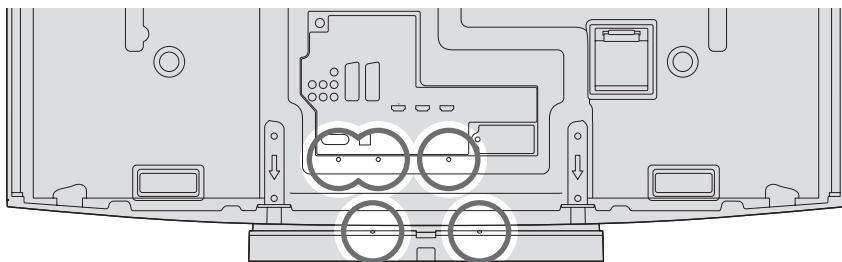

- Do not bundle the RF cable and mains lead together (could cause distorted image).
- Fix cables with clammers as necessary.
- When using the optional accessory, follow the option's assembly manual to fix cables.

### ■ Attach the clammer

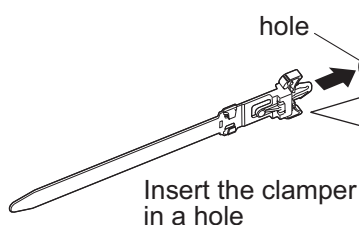

To remove from the TV:

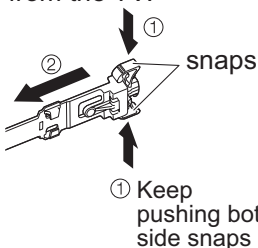

### ■ Bundle the cables

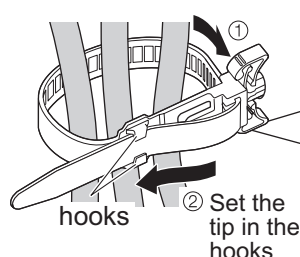

To loosen:

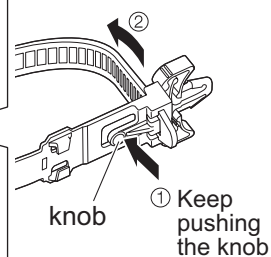

## Adjust the panel to your desired angle

- Ensure that the pedestal does not hang over the edge of the base even if the TV swivels to the full rotation range.
- Do not place any objects or hands within the full rotation range.

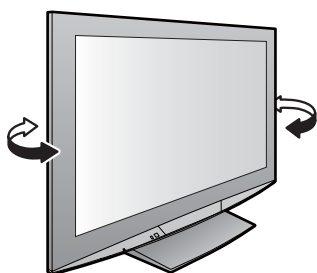

- TH-42PY800P  
a: 521 mm / b: 425 mm / c: 15°
- TH-50PY800P  
a: 513 mm / b: 453 mm / c: 10°

Set the mark at the centre as illustrated, to have the swivel positioned at the centre of the rotation angle.

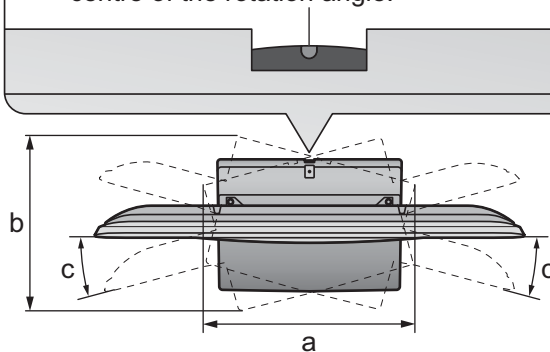

(View from the top)

# Identifying Controls

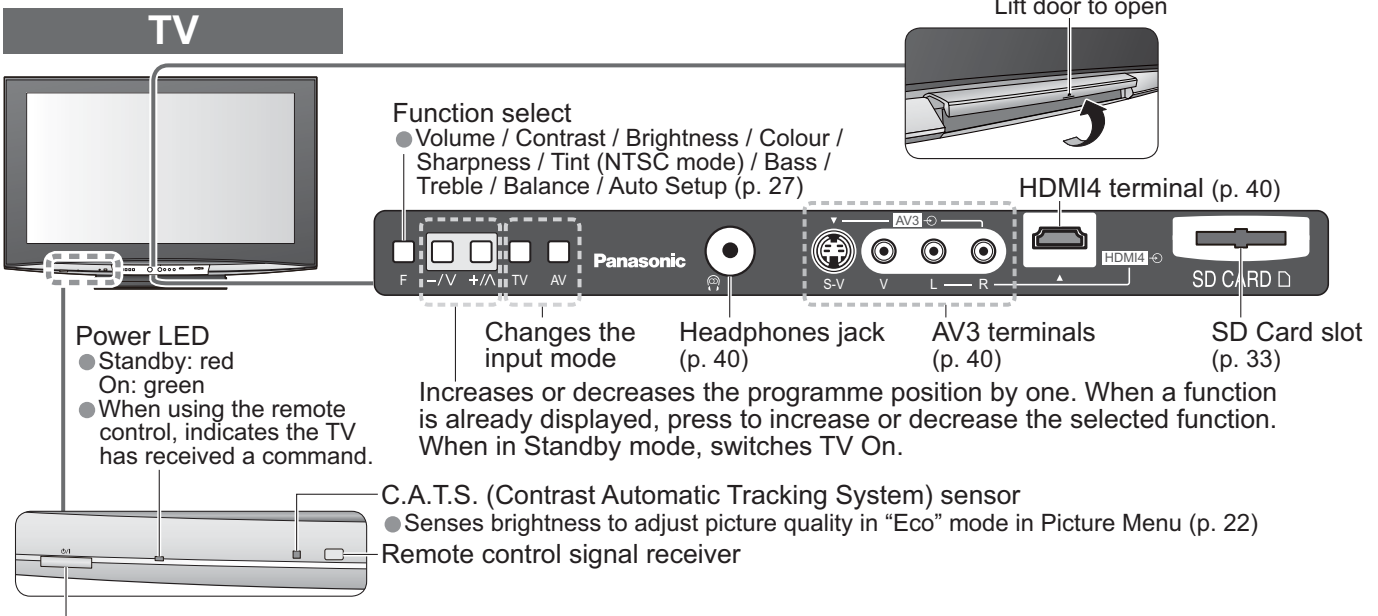

Mains power On / Off switch  
 ● Switch On to turn on the TV or turn the TV to standby mode by the remote control

## Remote Control

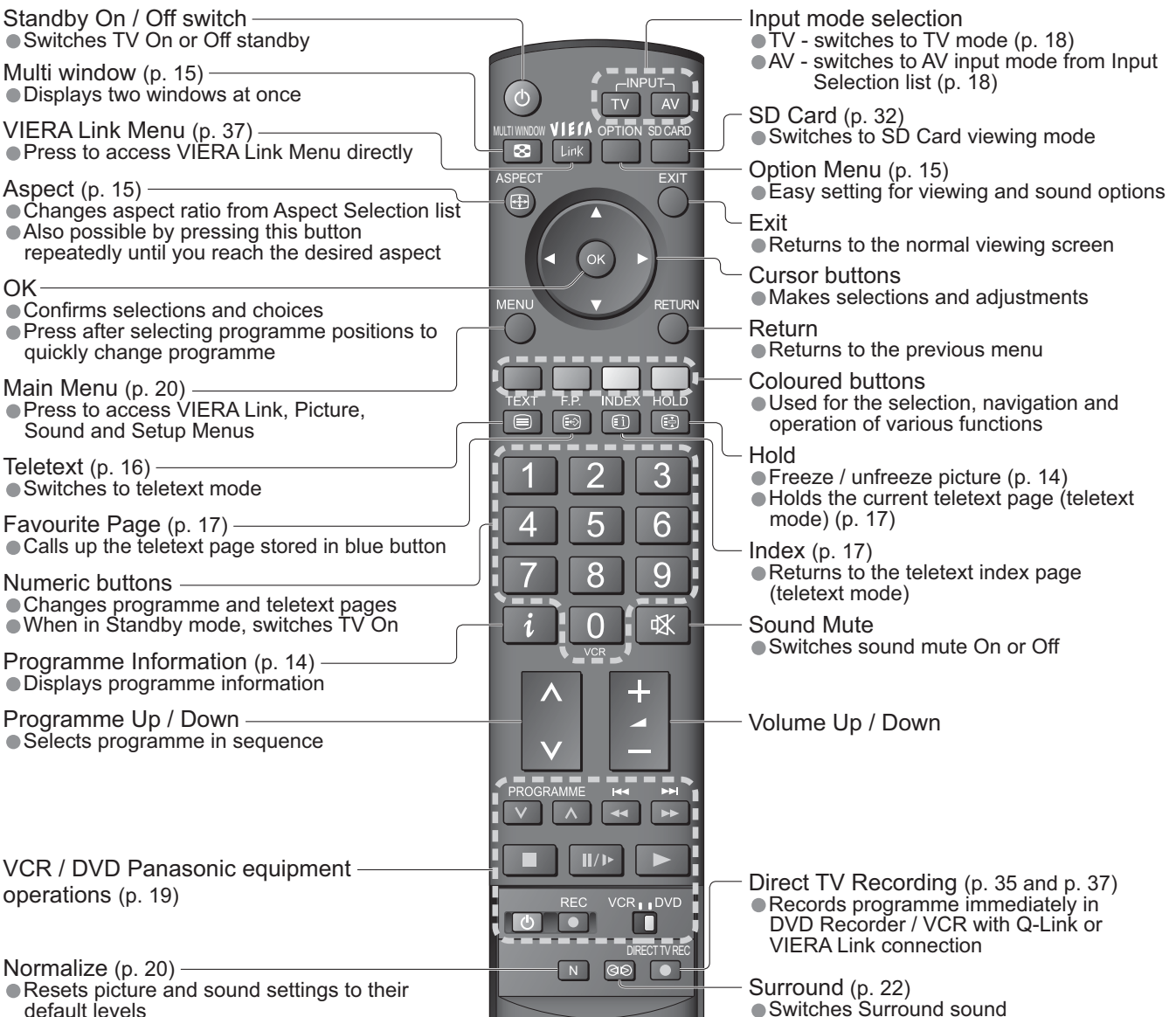

# Basic Connection

External equipment and cables shown are not supplied with this TV.

Please ensure that the unit is disconnected from the mains socket before attaching or disconnecting any leads. When disconnecting the mains lead, be absolutely sure to disconnect the mains plug at the socket outlet first.

## Example 1 Connecting aerial

TV only

Rear of the TV

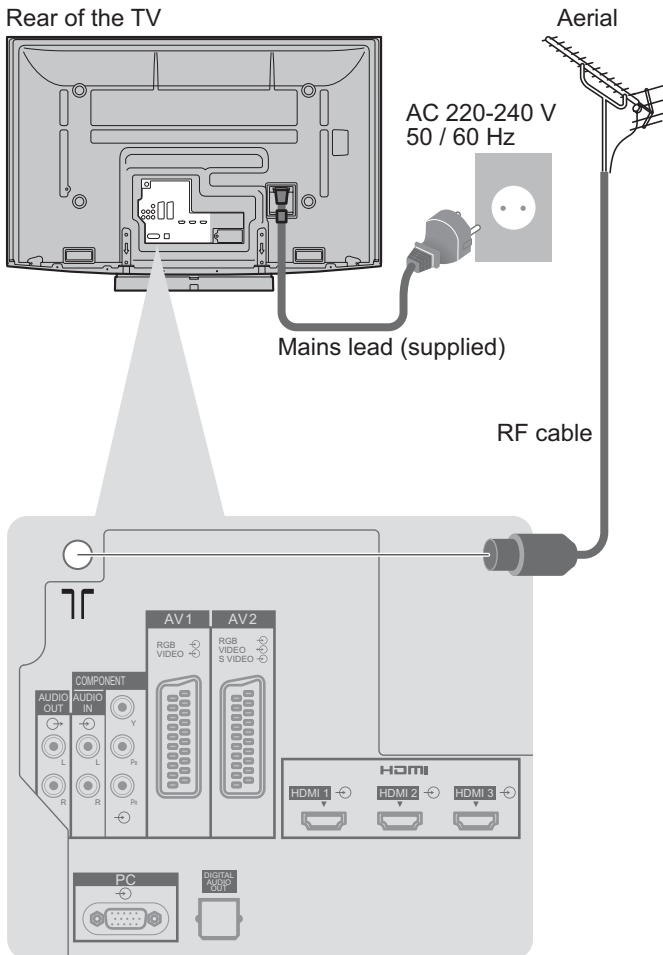

## Example 2 Connecting DVD Recorder / VCR

TV, DVD Recorder or VCR

Rear of the TV

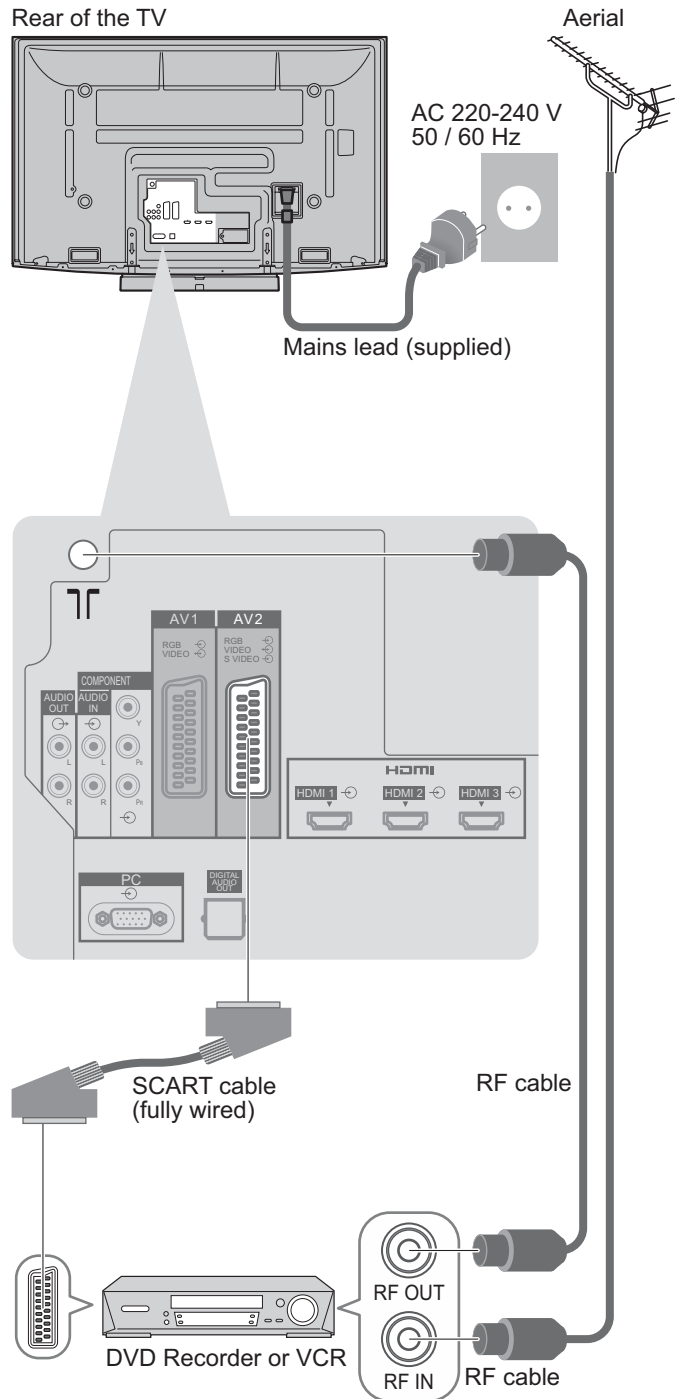

### Note

- Connect to AV1 / AV2 for a DVD Recorder / VCR supporting Q-Link (p. 35).
- For HDMI-compatible equipment, possible to connect to HDMI terminals (HDMI1 / HDMI2 / HDMI3 / HDMI4) by using HDMI cable (p. 40).
- Q-Link connection → p. 34
- VIERA Link connection → p. 34
- Read the manual of the equipment too.



# Auto Setup

Search and store TV programmes automatically.

These steps are not necessary if the setup has been completed by your local dealer.

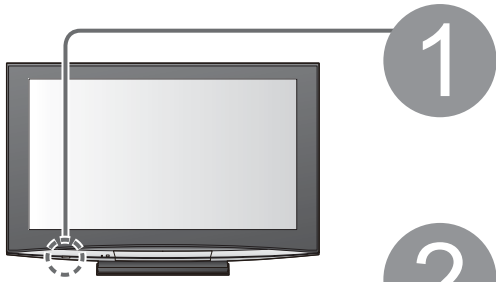

## 1 Plug the TV into mains socket and switch On (Takes a few seconds to be displayed)

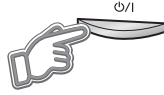

- You can now use the remote control to turn On the TV or turn the TV to standby mode. (Power LED: On)



## 2 Select the language

Menüsprache			
Deutsch	Dansk	Polski	Srpski
English	Svenska	čeština	Hrvatski
Français	Norsk	Magyar	Slovenščina
Italiano	Suomi	Slovenčina	Latviešu
Español	Türkçe	Български	eesti keel
Português	Ελληνικά	Română	Lietuvių
Nederlands			

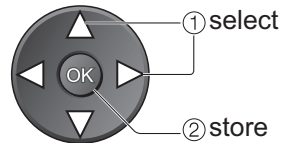

## 3 Select your country

Country		
Germany	Denmark	Poland
Austria	Sweden	Czech
France	Norway	Hungary
Italy	Finland	Ireland
Spain	Belgium	E. Eu
Portugal	Netherlands	
Switzerland	Greece	

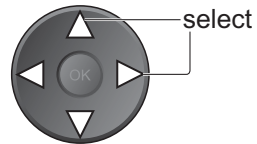

- Depending on the selected countries, you may also be required to select the region.



## 4 Start Auto Setup

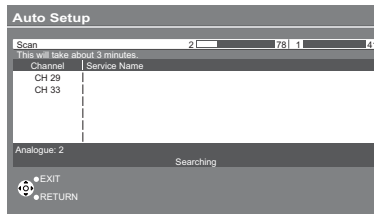

- Auto Setup will start to search for TV programmes and store them. The sorted programme order depends upon the TV signal, the broadcasting system and reception conditions.

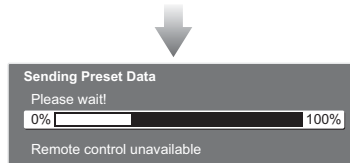

- If Q-Link, VIERA Link or similar technology (p. 34), compatible recorder is connected, programme, language, country / region settings are automatically downloaded to the recorder.



## 5 Select the picture setting

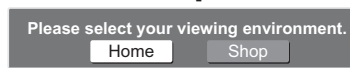

- "Shop" and "Home" are equal to "Dynamic" and "Normal" respectively - "Viewing Mode" in "Picture Menu" (p. 22)

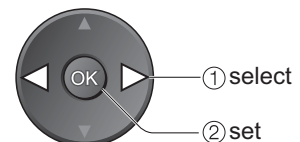

## Auto Setup is now complete and your TV is ready for viewing.



- To edit programmes  
➔ "Editing Programmes" (p. 24)

Using the  
On Screen  
Displays

Many features available on this TV can be accessed via the On Screen Display menu.

### ■ How to use remote control



Open the main menu



Move the cursor / select the menu



Move the cursor / adjust levels / select from a range of options



Access the menu / store settings after adjustments have been made or options have been set



Return to the previous menu



Exit the menu system and return to the normal viewing screen

### ■ ON SCREEN HELP Instructions box (example: Sound Menu)

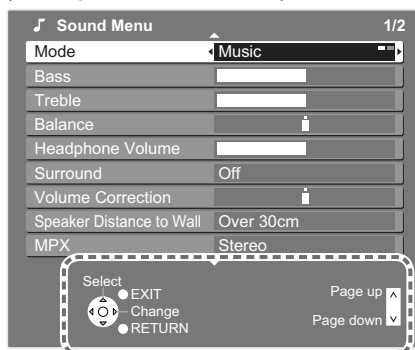

On-screen operation guide  
will help you.

#### Note

- If tuning has failed → “Auto Setup” (p. 27)
- If downloading has failed → “Download” (p. 23)
- To initialize all settings → “Shipping Condition” (p. 29)
- If you turned the TV Off during Standby mode last time, the TV will be in Standby mode when you turn the TV On with Mains power On / Off switch.

# Watching TV



**1**

**Turn power on**  
(Press for about 1 second)



● Mains power On / Off switch should be On. (p. 9)

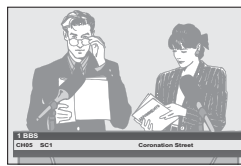

Information banner appears whenever you select a programme

● For details → see below

**2**

**Select a programme**

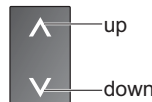

● To select the two or three-digit programme number, e.g. 39

→ 3 → 9  
(in a short time)

● To select from the Programme List

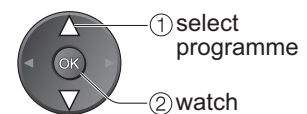
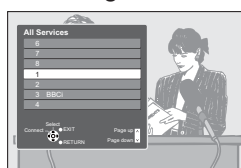

**Select a programme using Information banner** (see below)  
Possible to confirm the programme name before selecting programmes.

Display Information banner if it is not displayed → While the banner is displayed, select the programme

● Possible to set display timeout in "Banner Display Timeout" (p. 23).

**Other useful functions**

<b>Hold</b>	<p><b>Freeze / unfreeze picture</b> </p>
<b>Display Information banner</b>	<p><b>Display Information banner</b> </p> <p>● Also appears when changing a programme</p> <p>Example: </p> <p>Features available / Message meanings</p> <div style="border: 1px solid black; padding: 5px;"> <p> Sound mute On</p> <p> Teletext service available</p> <p><b>Stereo, Mono</b> Audio mode</p> <p><b>1 - 90</b> Off Timer remaining time ● For settings → see below</p> </div> <p>● To confirm another tuned programme name → </p> <p>● To watch the programme listed in the banner → </p> <p>● To hide → </p> <p>● To set display timeout → "Banner Display Timeout" (p. 23)</p> <p>● Event information is referred to teletext signal.</p>
<b>Off Timer</b>	<p><b>Turn the TV off automatically after a fixed period</b></p> <p>Display the menu  → Select "Setup" </p> <p>Select "Off Timer" and set the time </p> <p>● To cancel → Set to "Off" or turn the TV off.</p> <p>● To display the remaining time → Information banner (above)</p> <p>● When the remaining time is within 3 minutes, the remaining time will flash on screen.</p>

■ Other useful functions

Display the selectable settings for the current programme

**Check or change the current programme status instantly**



● To change

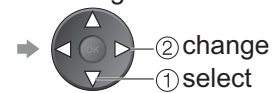

**Teletext Character Set**

Sets the teletext language  
➔ Setup Menu (p. 23)

**MPX**

➔ Sound Menu (p. 22)

**Volume Correction**

Adjusts volume of individual programme or input mode

**Note**

● Also possible to change the settings in Menu list (p. 22 and p. 23).

Change aspect ratio

**Change the aspect ratio**

ASPECT



Enjoy viewing the picture at its optimum size and aspect.

Display Aspect Selection list



While the list is displayed, select the mode

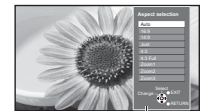

Aspect Selection list

● To change the mode using the ASPECT button only

➔ (Press repeatedly until you reach the desired mode)



**Auto**  
The best ratio is chosen and the picture expanded to fill the screen.  
For details ➔ p. 42



**16:9**  
Directly displays the image at "16:9" without distortion (anamorphic).



**14:9**  
Displays the image at the standard "14:9" without distortion.



**Just**  
Displays a "4:3" image full-screen. Stretching is only noticeable at the left and right edges.



**4:3**  
Displays the image at the standard "4:3" without distortion.



**4:3 Full**  
Displays a "4:3" image enlarged horizontally to fit the screen.  
● HD signal only



**Zoom1**  
Displays a "16:9" letterbox or "4:3" image without distortion.



**Zoom2**  
Displays a "16:9" letterbox (anamorphic) image full-screen without distortion.



**Zoom3**  
Displays a "2.35:1" letterbox (anamorphic) image full-screen without distortion. At "16:9", displays the image at its maximum (with slight enlargement).

- Only "16:9" and "4:3" are available in PC mode.
- Not available in teletext mode.
- Aspect mode can be memorized separately for SD (Standard definition) and HD (High definition) signals.

Watch TV, DVD, etc. in multi window

**View in multi window**

MULTI WINDOW



● Remote control operations apply to the main screen.

Enjoy viewing two images at once, such as a TV programme and a DVD.

**Picture-in-Picture mode (PinP)**

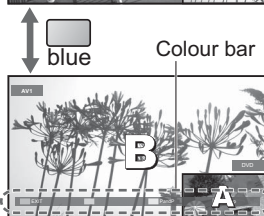

**Picture-and-Picture mode (PandP)**



■ Operations in multi window

- To exit multi window (return to the single-screen view with main screen) ➔
- To change the layout, images, first show the colour bar ➔

• To change the layout ➔ • To swap ➔ • To exit multi window ➔

• To change the input mode or programme of sub screen ➔ Swap sub screen for main screen ➔ Change the input mode or programme by the remote control (p. 14 or p. 18) ➔ Swap again

- The same input mode cannot be displayed at once.
- The sound is active for main screen only in multi window.
- You cannot change the aspect ratio in multi window.
- Multi window cannot be used with HDMI (available for main screen only), PC or SD Card.
- Some signals are reformatted for suitable viewing on your display.

# Viewing Teletext

You can enjoy teletext broadcasting, including news, weather forecasts and subtitles, if this service is provided by the broadcasters.

## What is FLOF (FASTTEXT) mode?

In FLOF mode, four differently coloured subjects are situated at the bottom of the screen. To access more information about one of these subjects, press the appropriately coloured button. This facility enables fast access to information on the subjects shown.

## What is TOP mode? (in case of TOP text broadcasting)

TOP is a particular improvement of the standard teletext service that results in an easier search and effective guide.

- Fast overview of the teletext information available
- Easy to use step-by-step selection of the topical subject
- Page status information at the bottom of the screen

- Available page up / down →
- To select among subject blocks →
- To select next subject within the subject block (After the last subject, it moves to the next subject block.) →

## What is List mode?

In List mode, four differently coloured page numbers are situated at the bottom of the screen. Each of these numbers can be altered and stored in the TV's memory. ("Store frequently viewed pages", p. 17)

■ To change mode → "Teletext" in Setup Menu (p. 23)

**1 Switch to Teletext**

TEXT ● Displays Index (content varies depending on the broadcasters)

Sub page number  
Current page number **P100** 17:51 28 Feb Time / date  
TELETEXT INFORMATION  
Colour bar

**2 Select the page**

1 2 3  
4 5 6  
7 8 9  
0 VCR

or

or (Corresponds to the colour bar)



















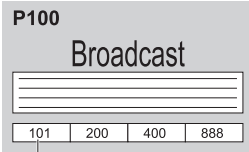

As the blue bar is displayed

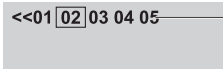
■ To adjust contrast → MENU (Press twice) →

■ To return to TV →

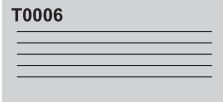
## Using teletext conveniently

<b>Reveal hidden data</b>	MENU → <b>Re-hide</b> →
<b>FULL / TOP / BOTTOM</b>	MENU → <div style="display: flex; justify-content: space-around; align-items: center;"> <div style="text-align: center;"> <p>(TOP)</p> <p>(Expand the TOP half)</p> </div> <div style="text-align: center;"> <p>(BOTTOM)</p> <p>(Expand the BOTTOM half)</p> </div> <div style="text-align: center;"> <p>Normal (FULL)</p> </div> </div>

<b>HOLD</b>	<p><b>Stop automatic updating</b> (If you wish to hold the current page without updating)</p> <p>HOLD  <b>To resume</b> → </p>
<b>INDEX</b>	<p><b>Return to the main index page</b></p> <p>INDEX </p>
<b>Call up a favourite page</b>	<p><b>View a favourite page stored</b></p> <p>F.P.  ● Call up the page stored in “blue”. ● Factory setting is “P103”.</p>
<b>View in multi window</b>	<p><b>Watch TV and Teletext in two windows at once</b></p> <p>MULTI WINDOW  </p> <p>● Operations can be made only in Teletext screen.</p>
<b>Store frequently viewed pages</b>	<p><b>Store frequently viewed pages in the colour bar</b> (List mode only)</p> <p>As page is displayed  →  press and hold</p> <p> The number changes to white.</p> <p><b>To change stored pages</b></p> <p>→  Colour button you want to change → Enter new page number</p> <p> →  press and hold</p>
<b>View sub page</b>	<p><b>View sub page (Only when teletext is more than one page)</b></p> <p>  Appears at top of the screen</p> <p><b>To view specific sub page</b></p> <p>→ MENU  →  blue  → Enter the 4-digit number</p> <p>example: P6  </p> <p>● Sub pages: The number of sub pages varies depending on the broadcasters (up to 79 pages). It may take some time for searching, during which time you can watch TV.</p>
<b>Watch TV while waiting for update</b>	<p><b>View the TV picture while searching for a teletext page</b> Teletext automatically updates itself when new information becomes available. Changes to TV screen temporarily</p> <p>MENU  →  yellow →  Appears when updating is completed →  yellow → View the updated page</p> <p>(You cannot change the programme.)</p> <p>● The news page provides a function that indicates arrival of latest news (“News Flash”).</p>

# Watching Videos and DVDs

Connect the external equipment (VCRs, DVD equipment, etc.) and you can watch the input.

● To connect the equipment → p. 10 and p. 11

The Remote Control is capable of operating some functions of selected Panasonic external equipment.

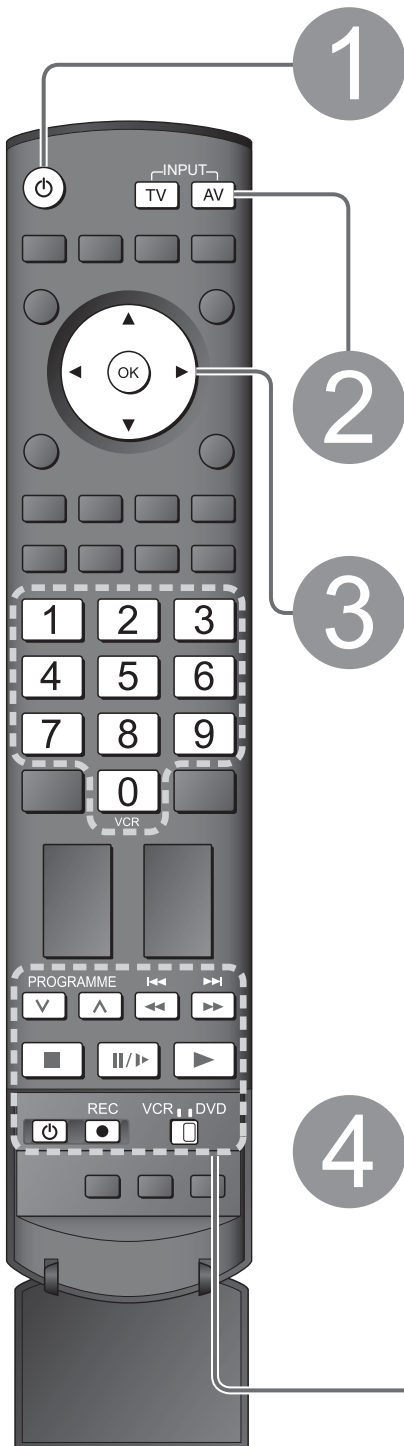

## 1 Turn the TV on

### ■ When connecting with SCART as example 2 or 3 (p. 10 and p. 11)

- ➔ Receives input signals automatically when playback starts
- Input signals are automatically identified by the SCART (pin 8) terminal.
- This function is also available for HDMI connections (p. 40).

### ■ If input mode is not switched automatically

- ➔ Perform 2 and 3
- Dependant on the setup of the equipment

## 2 Display the Input select menu



## 3 Select the input mode connected to the equipment

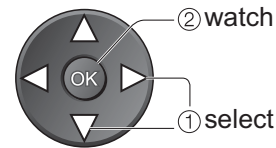
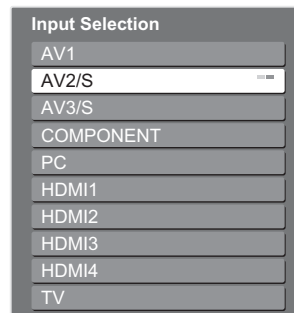

- You can also select the input using the AV button on the remote control or the front panel of the TV. Press the button repeatedly until the desired input is selected.
- You can label or skip each input mode → "Input Labels" (p. 30)

## 4 View

Displays the selected mode

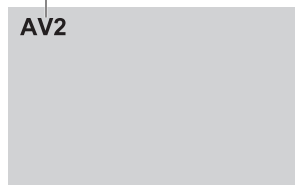









### ■ To return to TV





### Note

- If the external equipment has an aspect adjustment function, set to "16:9".
- For details, see the manual of the equipment or ask your local dealer.

Panasonic equipment connected to the TV can be directly operated with the remote control.

	<p><b>VCR / DVD switch*</b>            Select VCR to operate Panasonic VCR or DVD equipment            Select DVD to operate Panasonic DVD equipment or Player home theatre</p>
	<p><b>Standby</b>            Set to Standby mode / Turn on</p>
	<p><b>Play</b>            Playback videocassette / DVD</p>
	<p><b>Stop</b>            Stop the operations</p>
	<p><b>Rewind / Skip / Search</b>            VCR: Rewind, view the picture rapidly in reverse            DVD: Skip to the previous track or title            Press and hold to search backward</p>
	<p><b>Fast-forward / Skip / Search</b>            VCR: Fast-forward, view the picture rapidly forward            DVD: Skip to the next track or title            Press and hold to search forward</p>
	<p><b>Pause</b>            Pause / Resume            DVD: Press and hold to play at slow speed</p>
	<p><b>Programme Up / Down</b>            Select programme</p>
	<p><b>Record</b>            Start recording</p>

**\*Setting your remote control to operate Panasonic VCR, DVD, etc.**

- ① Set the VCR / DVD switch to the appropriate position → 
- ② Press and hold  during the following operations

Enter the appropriate code for the equipment to be controlled, see table below

→ Press 

“VCR” position

Equipment	Code
VCR	10 (default)
DVD	11

“DVD” position

Equipment	Code
DVD	70 (default)
Player home theatre	71

**Note**

- Confirm if the remote control works correctly after changing the code.
- The codes will be reset to default values if batteries are replaced.
- “DVD” means DVD player, DVD recorders and Recorder home theatre.
- Some operations may not be possible on some equipment models.

# How to Use Menu Functions

Various menus allow you to make settings for the picture, sound, and other functions.

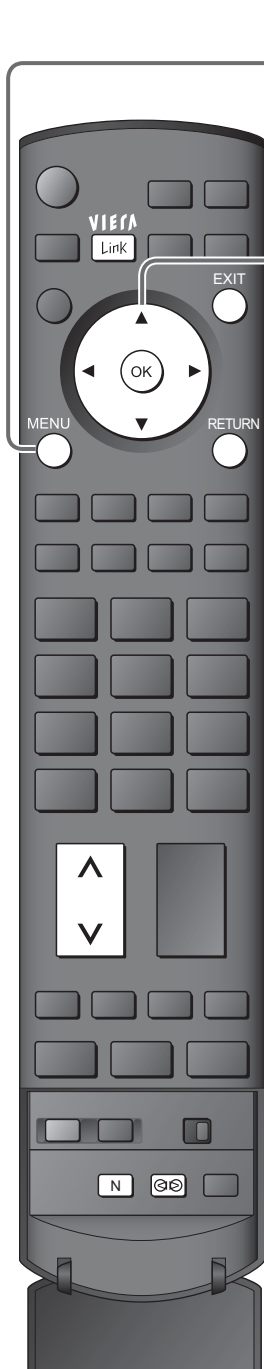

1

## Display the menu

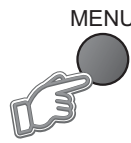

- Displays the functions that can be set (varies according to the input signal)

2

## Select the menu

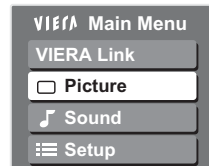

(example: Picture Menu)

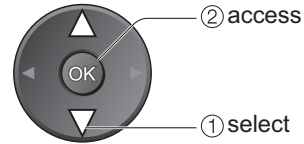

3

## Select the item

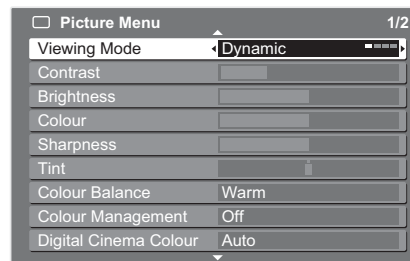

(example: Picture Menu)

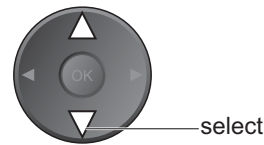

4

## Adjust or select

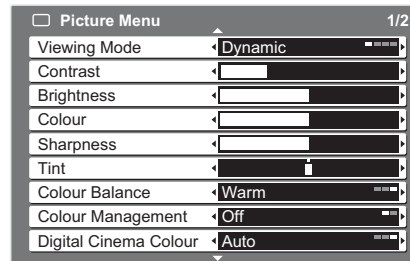

(example: Picture Menu)

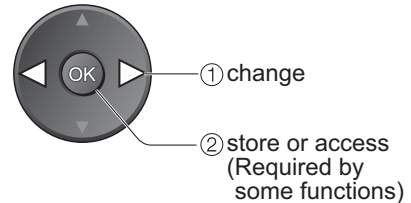

### ■ To return to TV at any time



### ■ To return to the previous screen



### ■ To change menu pages

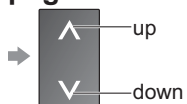

### ■ Choose from among alternatives

Number and positions of alternatives



Changed

### ■ Adjust using the slide bar

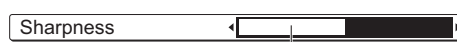

Moved

### ■ Go to the next screen



Displays the next screen

### ■ Enter characters by free input menu

You can enter names or numbers freely for some items.



Set characters

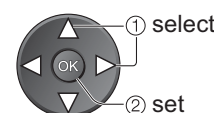

Store

RETURN



### ■ To reset the settings

- To reset the picture settings only  
→ "Reset to Default" in Picture Menu (p. 22)
- To reset the sound settings only  
→ "Reset to Default" in Sound Menu (p. 22)
- To reset the picture and sound settings together  
→ **N** (Also volume level and aspect mode are reset)
- To initialize all settings  
→ "Shipping Condition" in Setup Menu (p. 29)

■ Overview

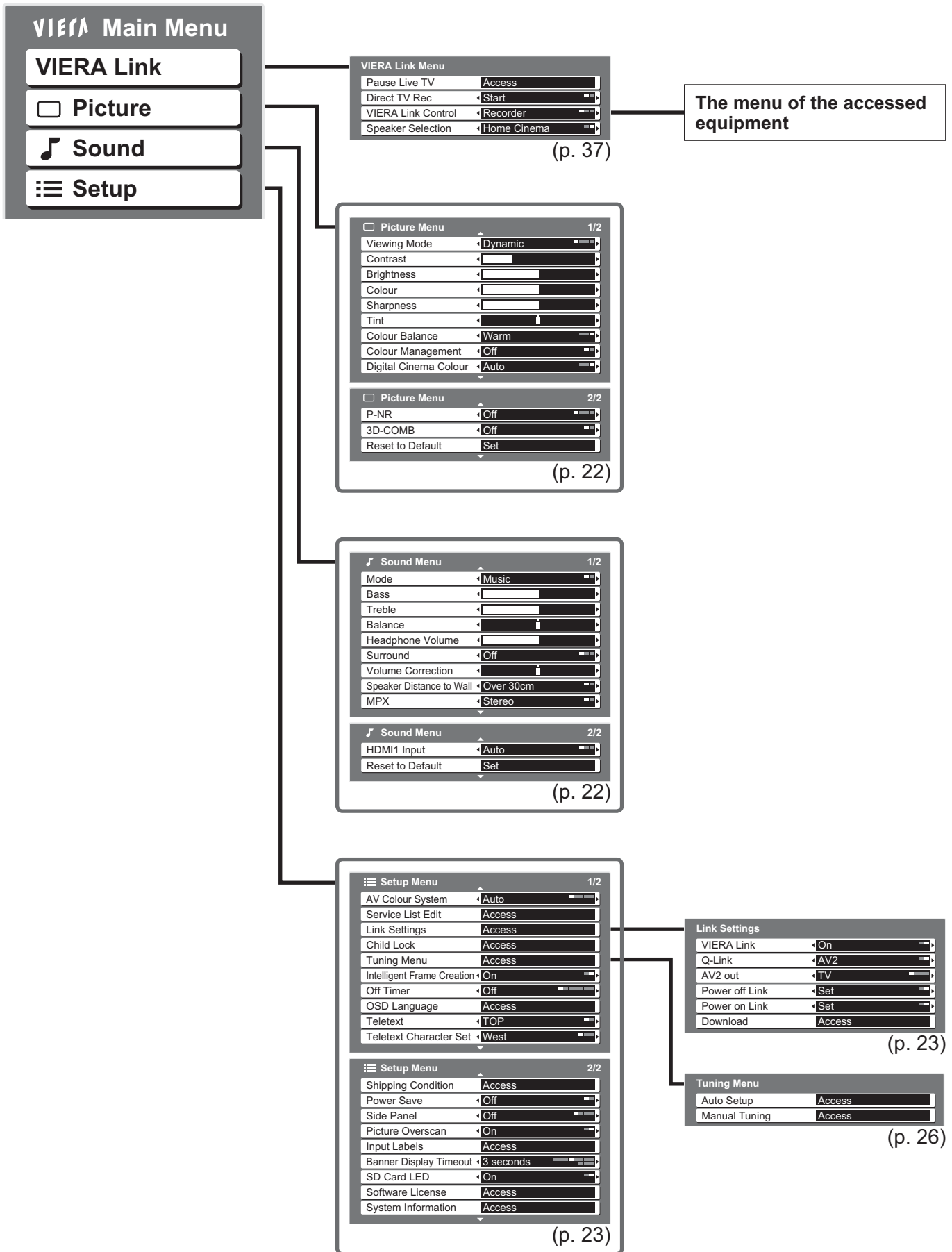

● How to Use Menu Functions (picture, sound quality, etc.)

Advanced

● Only available items can be selected.

# How to Use Menu Functions

## ■ Menu list

Menu	Item	Adjustments / Configurations (alternatives)
VIERA Link	Pause Live TV	Controls the connected equipment with VIERA Link function, and enables various convenient recording, playback, etc. (p. 37 - 39) ● You can also access VIERA Link Menu directly using the VIERA Link button on the remote control.
	Direct TV Rec	
	VIERA Link Control	
	Speaker Selection	
Picture	Viewing Mode	Basic picture mode ( <b>Dynamic / Normal / Cinema / Eco</b> ) Dynamic : Provides enhanced picture contrast and sharpness when viewing in a bright room Normal : Recommended for viewing under normal ambient room lighting conditions Cinema : For watching movies in a darkened room producing a cinema-like picture Eco : Adjusts picture settings automatically dependent on ambient lighting conditions ● Set for each input signal
	Contrast, Brightness, Colour, Sharpness	Increases or decreases the levels of these options according to your personal preference
	Tint	With an NTSC signal source connected to the TV, the picture hue can be adjusted to suit your taste ● For NTSC signal reception only
	Colour Balance	Allows you to set the overall colour tone of the picture ( <b>Cool / Normal / Warm</b> )
	Colour Management	Automatically adjusts colours to vivid ones ( <b>Off / On</b> ) ● Not valid on PC signal
	Digital Cinema Colour	Displays the vivid images with the expanded colour gamut ( <b>Off / On / Auto</b> ) This is effective when watching HD moving pictures ● HDMI input mode or Movie View Mode (p. 33) only
	P-NR	Picture Noise Reduction Automatically reduces unwanted picture noise and flicker noise in the contoured parts of a picture ( <b>Off / Min / Mid / Max</b> ) ● Not valid on PC signal
	3D-COMB	Occasionally, whilst viewing still or slow moving pictures, colour patterning may be seen Set to "On" to display sharper and more accurate colours ( <b>Off / On</b> ) ● For PAL or NTSC signal reception only ● Not valid on RGB, S-Video, Component, PC, HDMI and SD Card
	Reset to Default	Press the OK button to reset the present Picture Mode to the default settings
Sound	Mode	Basic sound mode ( <b>Music / Speech</b> )
	Bass	Increases or decreases level to enhance or minimise lower, deeper sound output
	Treble	Increases or decreases level to enhance or minimise sharper, higher sound output
	Balance	Adjusts volume level of right and left speakers
	Headphone Volume	Adjusts the volume of the headphones
	Surround	Surround sound settings ( <b>Off / Simulated Surround / SRS TruSurround XT</b> ) Simulated Surround: Provides a dynamic enhancer to simulate improved spatial effects SRS TruSurround XT: SRS TruSurround XT <sup>®</sup> creates a high quality surround sound effect using just two speakers from the source which can output surround encoded signals ● Switching is also possible by the Surround button on the remote control (p. 9).
	Volume Correction	Adjusts volume of individual programme or input mode
	Speaker Distance to Wall	Adjusts the low frequency sound ( <b>Over 30cm / Up to 30cm</b> ) ● If the back space between the TV and wall is over 30 cm, "Over 30cm" is recommended. ● If the back space between the TV and wall is within 30 cm, "Up to 30cm" is recommended.
	MPX	Select stereo / monaural ( <b>Mono / Stereo</b> ) ● Normally: Stereo ● Stereo signal cannot be received: Mono ● M1 / M2: Available while mono signal is transmitted
	HDMI1 / 4 Input	Select to fit the input signal ( <b>Auto / Digital / Analogue</b> ) (p. 42) Auto : Automatic detection of digital or analogue sound source Digital : HDMI cable connection Analogue : HDMI-DVI adapter cable connection ● HDMI input mode only ● HDMI2 / 3 terminals are for digital signal only ● No setting for HDMI2 / 3 available
Reset to Default	Press the OK button to reset the present Sound Mode to the default settings	

## Menu list

Menu	Item	Adjustments / Configurations (alternatives)	
Setup	<b>AV Colour System</b>	Selects optional colour system based on video signals in AV mode ( <b>Auto / PAL / SECAM / M.NTSC / NTSC</b> )	
	<b>Service List Edit</b>	Skips the unwanted programmes or edits programmes (p. 25)	
	Link Settings	<b>VIERA Link</b>	Sets to use VIERA Link functions ( <b>Off / On</b> ) (p. 36)
		<b>Q-Link</b>	Selects which AV terminal is to be used for data communication between this TV and a compatible recorder ( <b>AV1 / AV2</b> ) (p. 35) ● Select the connected terminal to the recorder even it is not compatible with Q-Link.
		<b>AV1 / AV2 out</b>	Chooses the signal to be transmitted from the TV to Q-Link ( <b>TV / AV1 / AV2 / AV3 / Monitor</b> ) ● Monitor: Image displayed on screen ● Component, PC and HDMI signals cannot be outputted.
		<b>Power off Link</b>	Sets to use Power off Link function ( <b>No / Set</b> ) (p. 35 and p. 36)
		<b>Power on Link</b>	Sets to use Power on Link function ( <b>No / Set</b> ) (p. 35 and p. 36)
		<b>Download</b>	Downloads programme, language, country / region settings to a Q-Link or VIERA Link compatible equipment connected to the TV
	Tuning Menu	<b>Child Lock</b>	Locks a programme / AV input to prevent access to it (p. 28)
		<b>Auto Setup</b>	Automatically sets the programmes received in the area (p. 27)
		<b>Manual Tuning</b>	Sets the programmes manually (p. 27)
		<b>Intelligent Frame Creation</b>	Automatically compensates the picture frame rate to make the image smooth ( <b>Off / On</b> ) ● Not valid on PC signal
		<b>Off Timer</b>	Sets the time the TV automatically turns Off ( <b>Off / 15 / 30 / 45 / 60 / 75 / 90 minutes</b> )
		<b>OSD Language</b>	Changes language for on-screen displays
		<b>Teletext</b>	Teletext display mode ( <b>TOP (FLOF) / List</b> ) (p. 16)
		<b>Teletext Character Set</b>	Selects teletext language ( <b>West / East1 / East2</b> ) ● West: English, French, German, Greek, Italian, Spanish, Swedish, Turkish, etc. ● East1: Czech, English, Estonian, Lettish, Rumanian, Russian, Ukrainian, etc. ● East2: Czech, Hungarian, Lettish, Polish, Rumanian, etc.
		<b>Shipping Condition</b>	Resets all settings, for example, when moving house (p. 29)
		<b>Power Save</b>	Reduces brightness of picture to economise on power consumption ( <b>Off / On</b> )
		<b>Side Panel</b>	Increases the brightness of the side panel ( <b>Off / Low / Mid / High</b> ) ● The recommended setting is "High" to prevent panel "image retention".
		<b>Picture Overscan</b>	Selects the screen area displaying the image ( <b>Off / On</b> ) On : Enlarged the image to hide the edge of the image. Off : Displayed the image in the original size. ● Set to "On" if noise is generated on the edge of the screen. ● This function is available when aspect is set to Auto (16:9 signal only) or 16:9. ● This function can be memorized separately for SD (Standard definition) and HD (High definition) signals.
		<b>Input Labels</b>	Labels or skips each input terminal (p. 30)
		<b>Banner Display Timeout</b>	Sets how long the information banner (p. 14) stays on screen ● 0 (No display) to 10 sec. in 1-sec. increments
		<b>SD Card LED</b>	Lights blue LED while SD Card is inserted ( <b>Off / On</b> ) (p. 33)
		<b>Software License</b>	Displays the software licence information
		<b>System Information</b>	Displays the system information of this TV

● A different menu will be displayed while PC or SD Card is used. (p. 31 and p. 33)

● Only available items can be selected.

● How to Use Menu Functions (picture, sound quality, etc.)

Advanced

# Editing Programmes

You can skip unwanted programmes or edit programmes.

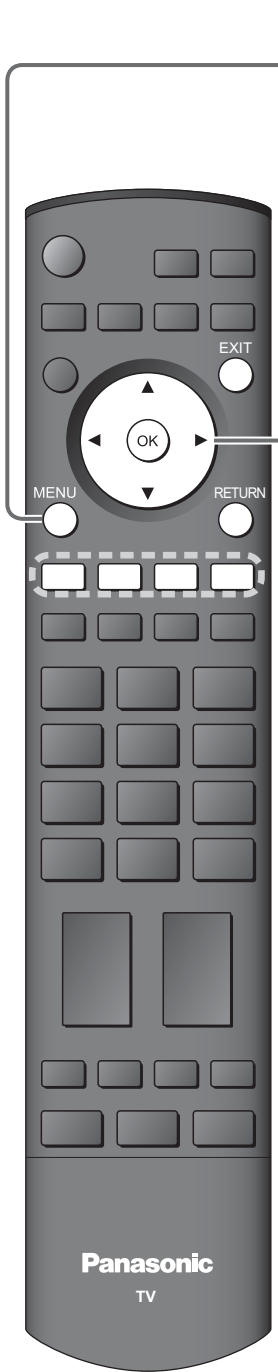

**1** **Display the menu**

MENU

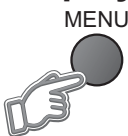

**2** **Select "Setup"**

VIERA Main Menu

VIERA Link
Picture
Sound
Setup

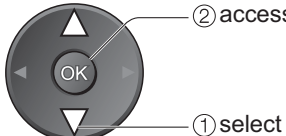

**3** **Select "Service List Edit"**

Setup Menu 1/2

Service List Edit	Access
Link Settings	
Child Lock	
Tuning Menu	
Intelligent Frame Creation	On
Off Timer	Off
OSD Language	
Teletext	TOP
Teletext Character Set	West

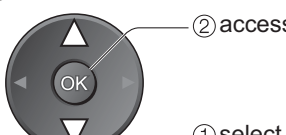

**4** **Set**

■ To return to TV

EXIT



Skip unwanted programmes

Edit programmes (Change name, Move)

Service List Edit

You can hide unwanted services. The deleted services cannot be displayed except in this function. Use this function to skip unwanted programmes.

### Select a service and add / delete

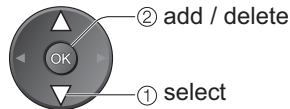
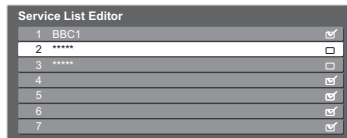

- :add
- :delete (skip)

- To retune each programme (Manual Tuning) → (p. 27)

You can change the programme name and programme position.

- If a VCR is connected only with the RF cable, edit "VCR".

### ① Select the programme to edit



Programme position  
Name



### ② Edit

#### ■ To change the name displayed when selecting programmes

Select "Rename"

Set characters

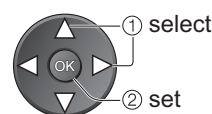

(maximum: five characters)

Store  
RETURN

#### ■ To move the programme position

Select new position

Select new position



Store

# Tuning Programmes

You can retune all the TV programmes when moving house or search for new services which may have recently started broadcasting.

**1 Display the menu**

MENU

**2 Select "Setup"**

VIERA Main Menu
VIERA Link
Picture
Sound
Setup

**3 Select "Tuning Menu"**

Setup Menu	1/2
Service List Edit	
Link Settings	
Child Lock	
Tuning Menu	Access
Intelligent Frame Creation	On
Off Timer	Off
OSD Language	
Teletext	TOP
Teletext Character Set	West

**4 Select a function**

Tuning Menu	
Auto Setup	Access
Manual Tuning	Access

**5 Set**

■ To return to TV

EXIT

Set all programmes automatically

**Auto Setup**

Automatically retune all programmes received in the area.  
 ● If a Child Lock PIN number (p. 28) has been set, it must be entered.

**Start Auto Setup**

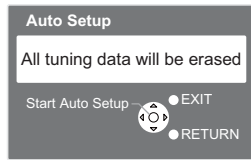

**Settings are made automatically**

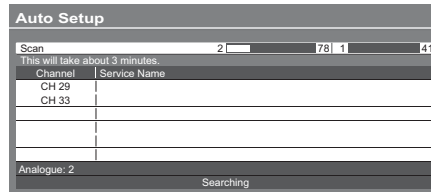

- All the previous tuning settings are erased.
- The programme, language, country / region settings are downloaded to a Q-Link or VIERA Link compatible equipment connected to the TV.
- When the operation is completed, the programme at programme position "1" will be displayed.
- If tuning has not been done completely → "Manual Tuning"

■ **For Auto Setup, using the buttons on the front of the TV (p. 9)**

① Press repeatedly until "Auto Setup" appears



F

② Access "Auto Setup"



TV

③ Start "Auto Setup"



TV

● To return to TV → F

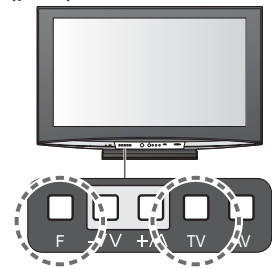

Set programme manually

**Manual Tuning**

■ **Fine Tuning**

Use to make small adjustments to the tuning of an individual programme (affected by weather conditions, etc.)

■ **Manual Tuning**

Set programme manually after Auto Setup.

- Set Sound System and Colour System, and then perform this function. Normally set Colour System "Auto".
- If a VCR is connected only with the RF cable, select programme position "0".

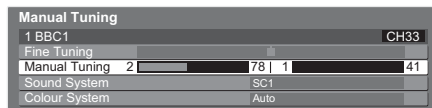

SC1: PAL B, G, H / SECAM B, G  
 SC2: PAL I  
 SC3: PAL D, K / SECAM D, K  
 F: SECAM L / L'

Select the programme position



Select the programme



Search and store



# Control Programme Audience

You can lock specific programmes / AV input terminals and control who watches them. (When the locked programme / input is selected, a message appears; by entering the PIN number, you can watch it.)

**1 Display the menu**  
MENU

**2 Select "Setup"**  
VIERA Main Menu  
VIERA Link  
Picture  
Sound  
Setup

**3 Select "Child Lock"**  
Setup Menu 1/2  
Service List Edit  
Link Settings  
Child Lock Access  
Tuning Menu  
Intelligent Frame Creation On  
Off Timer Off  
OSD Language  
Teletext TOP  
Teletext Character Set West

**4 Set**

■ To return to TV  
EXIT

## ① Enter the PIN number (4 digits)

Child Lock-PIN Entry  
Please enter new PIN  
PIN \* \* \* \*

1 2 3  
4 5 6  
7 8 9  
0 VCR

- Enter the PIN number twice at first setting.
- Make a note of the PIN number in case you forget it.

## ② Select "Child Lock List"

Child Lock  
Change PIN  
Child Lock List Access

② access  
① select

## ③ Select the programme / input to be locked

Child Lock List - Services and AV

Name	Type	Lock
VCR	TV	
1 BBC1	TV	🔒
2 ****	TV	
3 ****	TV	
4	TV	
5	TV	
AV1	AV	
AV2/S	AV	

② set  
① select

Appears when the programme / input is locked

- To cancel  
➔ Select the locked programme / input  
➔ OK
- To lock all ➔ yellow
- To cancel all locks ➔ blue

## ■ To change the PIN number

Select "Change PIN" in ② and enter a new PIN number twice.

### Note

- Setting "Shipping Condition" (p. 29) erases the PIN number and all settings.

## Control programme audience

### Child Lock

# Restore Settings

Resets the TV to its original condition, i.e. no programmes tuned in. All settings (programmes, picture, sound quality, etc.) are reset.

**1 Display the menu**  
 MENU

**2 Select "Setup"**  
 VIERA Main Menu  
 VIERA Link  
 Picture  
 Sound  
**Setup**

**3 Select "Shipping Condition"**  
 Setup Menu 2/2  
 Shipping Condition Access  
 Power Save Off  
 Side Panel Off  
 Picture Overscan On  
 Input Labels  
 Banner Display Timeout 3 seconds  
 SD Card LED On  
 Software License  
 System Information

**4 Set**

■ To return to TV  
 EXIT

**Restore Settings**

**Shipping Condition**

① **Check the message and initialise**

Shipping Condition

All tuning data will be erased  
 Are you sure?  
 Are you sure?

Confirm

● EXIT  
 ● RETURN

② **Follow the on-screen instructions**

- "Auto Setup" will automatically start when Mains power On / Off switch is next turned On. (p. 12)

■ **To retune TV programmes only, e.g. after moving house**

- ➔ "Auto Setup" (p. 27)

# Input Labels

For easier identification and selection of the input mode, you can label each input terminals or skip terminal that is not connected to any equipment.

● To select the input mode → p. 18

**1 Display the menu**

MENU

**2 Select "Setup"**

VIERA Main Menu

- VIERA Link
- Picture
- Sound
- Setup

**3 Select "Input Labels"**

Setup Menu 2/2

- Shipping Condition
- Power Save Off
- Side Panel Off
- Picture Overscan On
- Input Labels Access
- Banner Display Timeout 3 seconds
- SD Card LED On
- Software License
- System Information

**4 Select a input terminal and set**

Input Labels

AV1	DVD
AV2/S	AV2/S
AV3/S	AV3/S
COMPONENT	COMPONENT
PC	PC
HDMI1	HDMI1
HDMI2	HDMI2
HDMI3	HDMI3
HDMI4	HDMI4

**■ To return to TV**



The labels you set will be displayed in "Input Selection" menu (p. 18) or banner.

● If "Skip" is selected, you cannot select the mode.

**■ User input**

You can name each input terminals freely.

Select "User input"

Set characters

Store

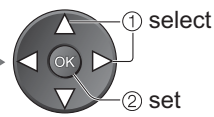
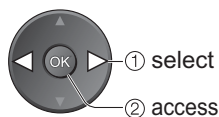

(maximum: ten characters)

# Displaying PC Screen on TV

The screen of the PC connected to the TV can be displayed on the TV.  
You can also listen to PC sound with the audio cable connected.

● To connect PC → p. 40

**1 Select the external input**



**2 Select "PC"**



**Input Selection**

- AV1
- AV2/S
- AV3/S
- COMPONENT
- PC**
- HDMI1
- HDMI2
- HDMI3
- HDMI4
- TV

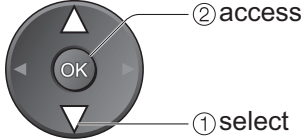

● Corresponding signals → p. 44  
● If "H-freq." or "V-freq." is shown in red, the signals may not be supported.

■ To return to TV



■ PC menu setting (changed as desired)

● To make settings → "How to Use Menu Functions" ① to ④ (p. 20)

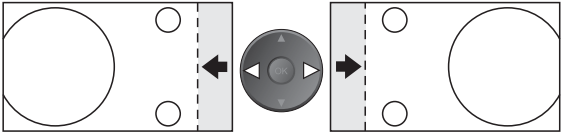
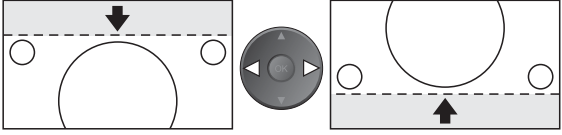
Menu	Item	Adjustments / Configurations (options)
Picture	W/B High R	White balance of bright red area
	W/B High B	White balance of bright blue area
	W/B Low R	White balance of dark red area
	W/B Low B	White balance of dark blue area
	Gamma	(S Curve / 2.0 / 2.2 / 2.5)
	Reset to Default	Press the OK button to reset to the default Picture settings
Setup	Input Resolution	Switches to a wide view ● VGA (640 × 480 pixels), WVGA (852 × 480 pixels), XGA (1,024 × 768 pixels), WXGA (1,366 × 768 pixels) ● Options change depending on signals
	Clock	Set to the minimum level if noise occurs
	H-pos	Adjusts horizontal position 
	V-pos	Adjusts vertical position 
	Clock Phase	Eliminates flicker and distortion ● Adjust after Clock adjustment ● Set to the minimum level if noise occurs
	Sync	Chooses another synchronous signal if the image is distorted ( <b>H &amp; V / On G</b> ) ● H & V : by the horizontal and vertical signals from your PC On G : by the green signal from your PC (if available)
	Reset to Default	Press the OK button to reset to the default Setup settings

● Other items → p. 22 and p. 23

# Viewing from SD Card

**Photo View:** Still images recorded by digital cameras will be displayed.

**Movie View:** Moving pictures recorded by digital video cameras will be played back.

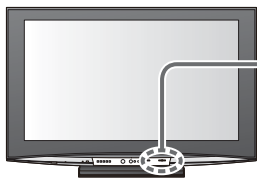

**1** Insert the SD Card

**2** Select "Photo View" or "Movie View"

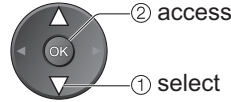
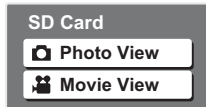

**3** Select the file to be viewed



## Photo View

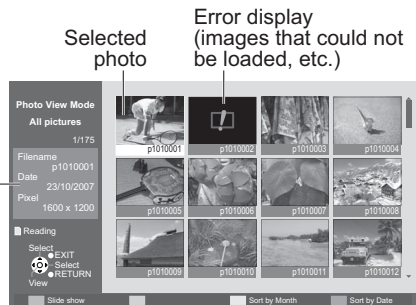

Selected photo information is displayed (Thumbnail)

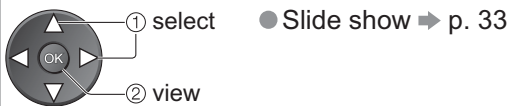

**To sort by date or month recorded**  
(Sort by Month / Sort by Date)

Display the thumbnail grouped by the same date or the same month

(Sort by Month)

(Sort by Date)

● The group of the photos without record of the date is shown as "Unknown".

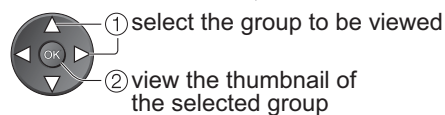

## View

Displayed one at a time

● To display / hide the operation guide

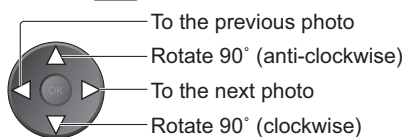

● To return to thumbnail



## Movie View

File format:

Only AVCHD or MPEG2 are supported. Selected movie

● For details → p. 43

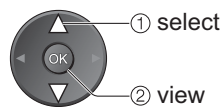
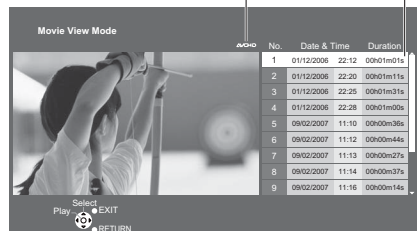

## View

Playback will start

● To display the operation guide



● To hide the operation guide →

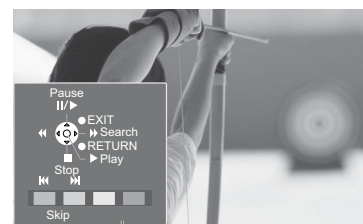

Operation guide

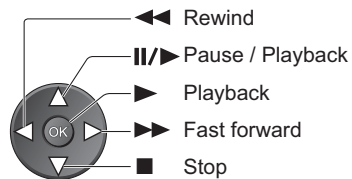

● To the previous movie →

● To the next movie →

● To return to list → (stop)

● To display information banner →

● To change aspect ratio (only for the 4:3 movie content) →

# (Photos and Movies)

## SD Card

- For details on SD Cards → p. 43

■ **To insert**

Label surface → Push until a click is heard

■ **To remove**

Press the centre of the card

**Note**

- Blue LED lights while SD Card is inserted if set "SD Card LED" to "On" in Setup Menu (p. 23).

Blue LED

- During the operation, no signals are output from any of the AV terminals. But the sound in Movie View can be output from AUDIO OUT and DIGITAL AUDIO OUT terminals.
- "Date" shows the date on which the recording was made by the digital camera or digital video camera. The file without record of the date is shown "\*\*\*/\*\*/\*\*\*\*".

## Slide show (Photo View)

■ **Start Slide show** (operate in step ③)

- ① Select the photo for the first view
- ② Start Slide show
- To pause →
- To return to Single view →

**Note**

● Slide show is done within the same group if started from the view of the group.

■ **Slide show settings** (operate in step ③)

- ① Display the menu
- ② Select "Viewing Setup"
  - "Picture Menu" → p. 22
- ③ Select the items and set
  - Interval: 5 seconds
  - Repeat: Off

Menu	Item	Adjustments / Configurations (alternatives)
Viewing Setup	Interval	Select slide show interval (5 / 10 / 15 / 30 / 60 / 90 / 120 seconds)
	Repeat	Slide show repeat (Off / On)

## Audio Settings (Movie View)

You can enjoy the multi-channel sound via an amplifier connected to DIGITAL AUDIO OUT terminal.

■ **To confirm or change the current sound status** (while viewing movies)

- ① Display the Option menu
- ② Change the sound (if the movie has multiple audio signals)
- It may take several seconds to change the sound.

■ **Audio output settings** (operate in step ③)

- ① Display the menu
- ② Select "Sound"
  - Other items → p. 22 and p. 23
- ③ Select "SPDIF Selection" and set
  - Mode: Music
  - SPDIF Selection: Auto

Menu	Item	Adjustments / Configurations (alternatives)
Sound	SPDIF Selection	SPDIF : A standard audio transfer file format Selects the initial setting for digital audio output signal from DIGITAL AUDIO OUT terminal (Auto / PCM) Auto: Dolby Digital is output as Dolby Digital Bitstream. MPEG is output as PCM. PCM: Digital output signal is fixed to PCM.

# Link Functions (Q-Link VIERA Link)

Q-Link connects the TV and DVD Recorder / VCR, and enables easy recording, playback, etc. (p. 35)  
 VIERA Link (HDAVI Control™) connects the TV and the equipment with VIERA Link function, and enables easy control, convenient recording, playback, etc. (p. 36 - 39)  
 You can use Q-Link and VIERA Link functions together.

## Summary of Q-Link and VIERA Link functions

Features	Connection	Q-Link (SCART connection)	VIERA Link (HDMI connection only)	VIERA Link (SCART and HDMI connection)
Preset download		○	○**	○
Easy playback		○	○	○
Power on link		○	○	○
Power off link		○	○	○
Speaker control		—	○	○
Control the menu of the connected equipment by VIERA remote control		—	○*	○*
Direct TV Recording		○	—	○**
Pause Live TV programme		—	—	○**

\* : Available with the equipment which has "HDAVI Control 2" or "HDAVI Control 3" function.

\*\* : Available with the equipment which has "HDAVI Control 3" function.

## Connections

Read the manual of the equipment, too.

### Q-Link

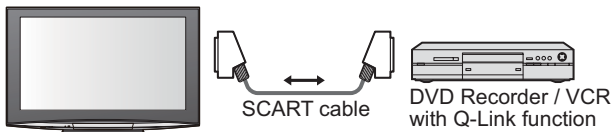

- Connect the DVD Recorder / VCR supporting Q-Link to the TV's AV1 or AV2 terminal via a fully wired SCART cable.

### VIERA Link

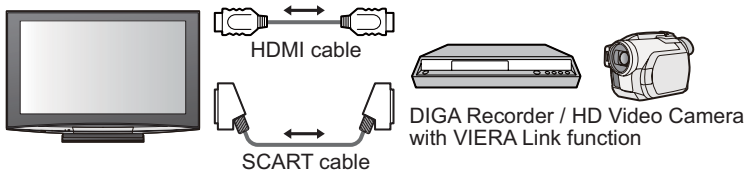

- Connect the equipment supporting VIERA Link to the TV's AV1, AV2, HDMI1, HDMI2, HDMI3 or HDMI4 terminals via fully wired SCART and HDMI cables together.
- Some functions are available only with HDMI cable connection. But use both HDMI and SCART cables to support many features normally.

- SCART cable  
Use fully wired SCART cable.
- HDMI cable  
Use fully wired HDMI compliant cable. Non-HDMI-compliant cables cannot be utilized.  
Recommended Panasonic's HDMI cable part number:  
 • RP-CDHG10 (1.0 m)  
 • RP-CDHG15 (1.5 m)  
 • RP-CDHG20 (2.0 m)  
 • RP-CDHG30 (3.0 m)  
 • RP-CDHG50 (5.0 m)

### For Speaker control (Home Cinema)

- To use Amplifier

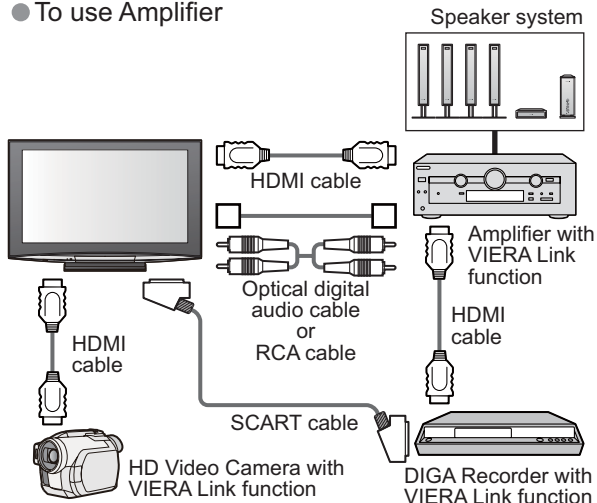

- To use Player theatre

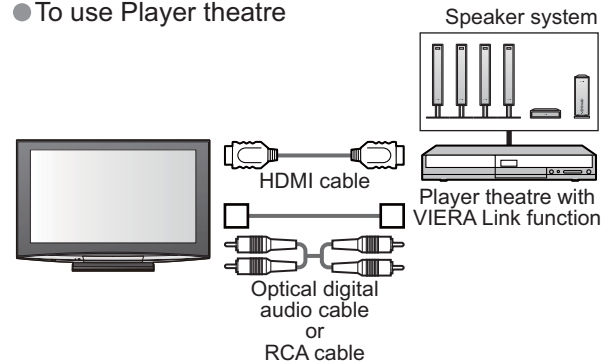

## Q-Link

### ■ Preparations

- Connect the DVD Recorder / VCR with the following logos: "Q-Link", "NEXTVIEWLINK", "DATA LOGIC", "Easy Link", "Megalogic" or "SMARTLINK"
- Q-Link connection → p. 34
- Set up the DVD Recorder / VCR. Read the manual of the equipment.
- Q-Link terminal setup in Setup Menu → "Q-Link" (p. 23), "AV1 / AV2 out" (p. 23)
- Download preset - programme, language, country / region setting (Preset download) → "Download" (p. 23) or "Auto Setup" (p. 27) or "Auto Setup" - when first using the TV (p. 12)

### ■ Features available

Some recorders are not applicable. Read the manual of the recorder.

Recording the current programme in DVD Recorder / VCR immediately.

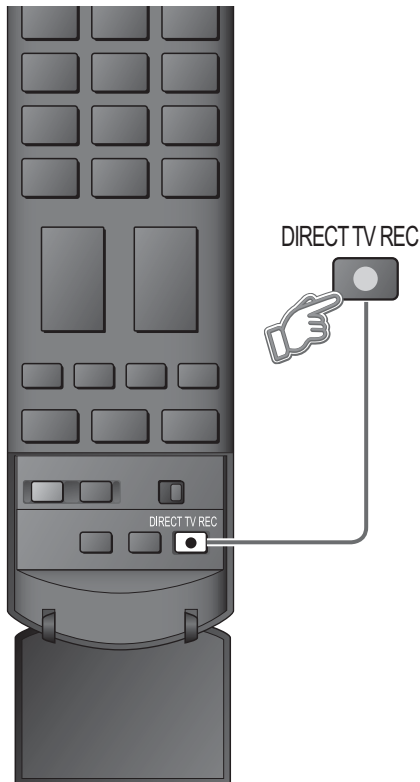

- Available conditions:

Current mode	Using tuner	How to record
TV	TV	TV monitor out
	Recorder	Recorder's tuner
AV (watching recorder's tuner)	Recorder	Recorder's tuner
AV (watching recorder's external input)	—	Recorder's external input
AV (watching TV's external input)	—	TV monitor out

- When Direct TV Recording is performed, the recorder is automatically turned on if it is in Standby mode.
- Changing programme or turning off the TV is available while the recorder is recording from its own tuner.
- Changing programme is not available while the recorder is recording from the TV tuner.
- Turning off the TV will stop the recording if the recording from an AV source connected to the TV.

Direct TV Recording - What you see is What you record

Information / Message

Recording information or if recording is not possible, a message is displayed.

Power on link and Easy playback

**Set Power on Link "Set" in Setup Menu to use this function**

→ "Power on Link" (p. 23)

When DVD Recorder / VCR starts playback or direct navigator / function menu for the equipment are activated, the TV is turned on and input mode is switched automatically so that you can view the content. (Only when TV is in Standby mode.)

Power off link

**Set Power off Link "Set" in Setup Menu to use this function**

→ "Power off Link" (p. 23)

When TV is set to Standby mode, the recorder is also automatically set to Standby. (Only when the videocassette or DVD is not active.)

- "DATA LOGIC" (a trademark of Metz Corporation)
- "Easy Link" (a trademark of Philips Corporation)

- "Megalogic" (a trademark of Grundig Corporation)
- "SMARTLINK" (a trademark of Sony Corporation)

# Link Functions (Q-Link VIERA Link)

## VIERA Link “HDAVI Control™”\*

\*Enjoy additional HDMI Inter-Operability with Panasonic products which have “HDAVI Control” function. This TV supports “HDAVI Control 3” function.

Connections to the equipment (DIGA Recorder, HD Video Camera, Player theatre, Amplifier, etc.) with HDMI and SCART cables allow you to interface them automatically.

These features are limited to models incorporating “HDAVI Control” and “VIERA Link”.

- Some functions are not available depending on the equipment’s version of HDAVI Control. Please confirm the connected equipment’s version of HDAVI Control.
- VIERA Link “HDAVI Control”, based on the control functions provided by HDMI which is an industry standard known as HDMI CEC (Consumer Electronics Control), is a unique function that we have developed and added. As such, its operation with other manufacturers’ equipment that supports HDMI CEC cannot be guaranteed.

Please refer to individual manuals for other manufacturers’ equipment supporting VIERA Link function. About applicable Panasonic equipment, consult your local Panasonic dealer.

### ■ Preparations

- Connect the equipment supporting VIERA Link.
  - VIERA Link connection ➔ p. 34
  - Set up the connected equipment. Read the manual of the equipment.
  - For optimal recording, the settings of the recorder might be required. For details, read the manual of the recorder.
  - Download preset - programme, language, country / region setting (Preset download)
    - ➔ “Download” (p. 23) or “Auto Setup” (p. 27) or “Auto Setup” - when first using the TV (p. 12)
  - Set VIERA Link On in Setup Menu ➔ “VIERA Link” (p. 23)
  - Set up the TV
    - ➔ **After connection, turn the equipment on and then switch the TV on. Select the input mode to HDMI1, HDMI2, HDMI3 or HDMI4 (p. 18), and make sure that an image is displayed correctly.**
- This setup should be done each time when the following conditions occur:
- for the first time
  - when adding or reconnecting equipment
  - when changing setup

### ■ Features available

<b>Easy playback</b>	Automatic Input switching - When the connected equipment is operated, input mode is switched automatically. When it is stopped operating, input mode is returned.
<b>Power on link</b>	<p><b>Set Power on Link “Set” in Setup Menu to use this function</b></p> <p>➔ “Power on Link” (p. 23)</p> <p>When the connected equipment starts playback or direct navigator / function menu for the equipment are activated, the TV is automatically turned on. (Only when TV is in Standby mode.)</p>
<b>Power off link</b>	<p><b>Set Power off Link “Set” in Setup Menu to use this function</b></p> <p>➔ “Power off Link” (p. 23)</p> <p>When TV is set to Standby mode, the connected equipment is also automatically set to Standby.</p> <ul style="list-style-type: none"> <li>● This function will work even if the TV enters standby mode automatically by Off Timer function or auto power standby function.</li> </ul>

■ Features available (Using VIERA Link Menu)

Pause Live TV programme  
(HDAVI Control 3 and Recorder with HDD)

Pause Live TV

You can pause the live TV programme and resume later.

- This function is available with DIGA Recorder which has HDD and "HDAVI Control 3" function.
- Connect DIGA Recorder with both HDMI and SCART cables to use this function.
- If you cannot operate, check the settings and the equipment → "Preparations" (p. 36)

Access and pause the live TV programme



① Display "VIERA Link Menu"



② Select "Pause Live TV" and pause

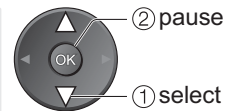
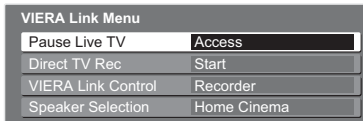

- Live TV programme is recorded on HDD from where it was paused.

■ To resume (stop pause)

Select "Pause Live TV" and access

- About the operations after resuming, read the manual of the equipment.

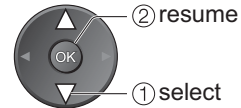

■ To return to Live TV

(cancel pause or resumed playback)

→ TV (change the input mode)

- If you cancel pause or resumed playback, the recorded programme will be deleted from HDD.

Recording the current programme in DIGA Recorder immediately.

- This function is available with DIGA Recorder which has "HDAVI Control 3" function.
- Connect DIGA Recorder with both HDMI and SCART cables to use this function.
- If you cannot operate, check the settings and the equipment → "Preparations" (p. 36)
- Changing programme or turning off the TV is available while the recorder is recording from its own tuner.
- Changing programme is not available while the recorder is recording from the TV tuner.
- Turning off the TV will stop the recording if the recording from an AV source connected to the TV.

Direct TV Recording -  
What you see is What you record  
(HDAVI Control 3)

Direct TV Rec



① Display "VIERA Link Menu"



② Select "Direct TV Rec" and start recording

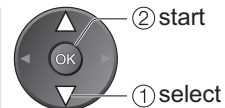
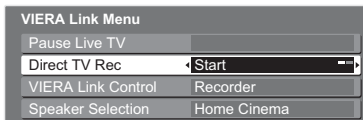

- You can also start recording directly → DIRECT TV REC

■ To stop recording

Select "Stop" in "Direct TV Rec" and access

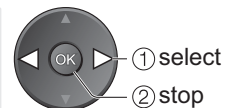
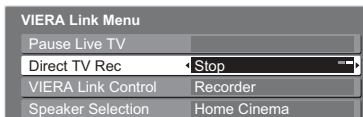

# Link Functions (Q-Link VIERA Link)

## ■ Features available (Using VIERA Link Menu)

You can control some functions of the connected equipment with this TV remote control (point the remote control at the TV's signal receiver).

- This function is available with the equipment which has "HDAVI Control 2" or "HDAVI Control 3" function.
- If you cannot operate, check the settings and the equipment → "Preparations" (p. 36)

### Access and operate the menu of the equipment

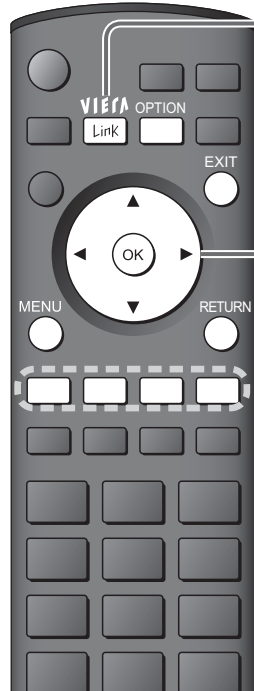

① Display "VIERA Link Menu"



② Select "VIERA Link Control"

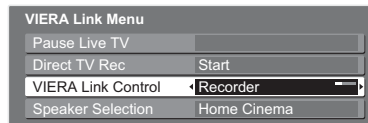

③ Select the equipment you want to access

- "Home Cinema" means Player theatre, Recorder theatre and Amplifier.

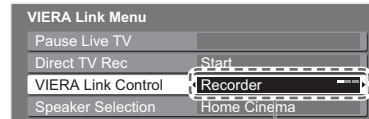

Recorder / Player / Home Cinema / Video Camera

The type of the connected equipment is displayed.

Select the type of the equipment and access.

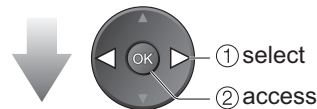

The menu of the accessed equipment (Input mode will be changed automatically)

④ Operate the menu of the equipment

- Available VIERA remote control buttons (depending on the connected equipment):

	Move the cursor / select the menu
	Move the cursor / access / adjust
	Store / set / access
	Return to the previous menu
	Exit the menu
	Display the operation guide for the equipment / The same functions with the OPTION button of the equipment
	Access when the key words are displayed on colour bar

- About the operations for the equipment, read the manual of the equipment.

Control the menu of the connected equipment by VIERA remote control

(HDAVI Control 2)  
(HDAVI Control 3)

VIERA Link Control

### ■ If you access the invalid equipment

When the equipment with "HDAVI Control" function is connected

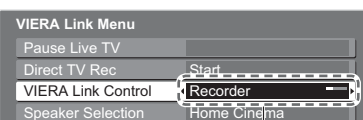

Recorder / Player / Home Cinema / Video Camera

The type of the connected equipment is displayed. But you cannot access it. Use its own remote control to operate the equipment.

When the equipment of other types or manufacturers is connected

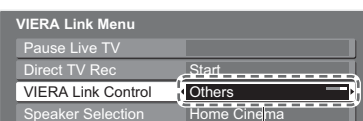

Others

"Others" is displayed. You cannot access it. Use its own remote control to operate the equipment.

■ Features available (Using VIERA Link Menu)

You can control the theatre speaker with this TV remote control (point the remote control at the TV's signal receiver).

- This function is available with the Amplifier or Player theatre which has "HDAVI Control" function.
- If you cannot operate, check the settings and the equipment → "Preparations" (p. 36)

**Access and control the speaker volume**

Speaker control

Speaker Selection

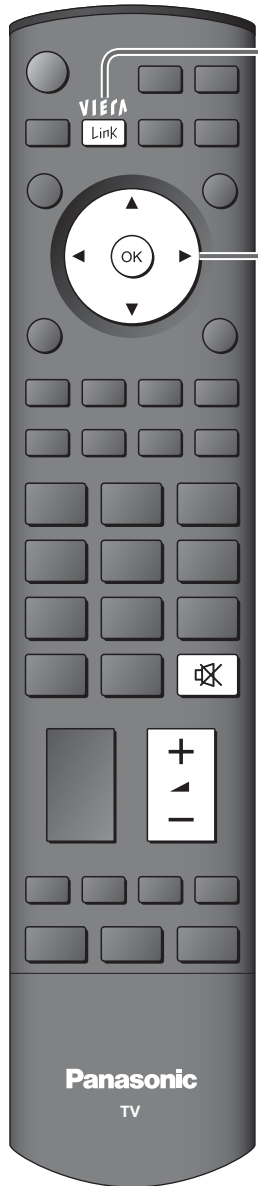

① Display "VIERA Link Menu"



② Select "Speaker Selection"

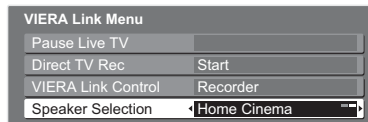

③ Set to "Home Cinema" or "TV"



■ Home Cinema

Amplifier or Player theatre will be automatically turned on if it is in Standby mode and the sound is from theatre speakers connected to the equipment.

- Volume up / down →
- Mute →
- The sound of TV speakers is mute.
- When the equipment is turned off, TV speakers will be active.

■ TV

TV speakers are active.

**Note**

- This function may not work properly depending on the connected equipment.
- Image or sound may not be available for the first few seconds when the playback starts.
- Image or sound may not be available for the first few seconds when Input mode is switched.
- Volume function will be displayed when adjusting the volume of the equipment.
- Easy playback is also available by using the remote control for Amplifier or Player theatre. Read the manual of the equipment.
- About HDMI cable for connecting Panasonic HD Video Camera, read the manual of the equipment.
- If more than one equipment of the same type are connected to the TV by HDMI cables, for example two DIGA Recorders to HDMI1 and HDMI2, VIERA Link will only be available for the lower terminal number, in this case HDMI1.
- "HDAVI Control 3" is the newest standard (current as of December, 2007) for HDAVI Control compatible equipment. This standard is compatible with conventional HDAVI equipment.
- To confirm this TV's version of HDAVI Control → "System Information" (p. 23)

# External Equipment

These diagrams show our recommendations for how to connect the TV to your various equipment. For other connections, consult the instructions for each piece of equipment, the table below, and the specifications (p. 47).

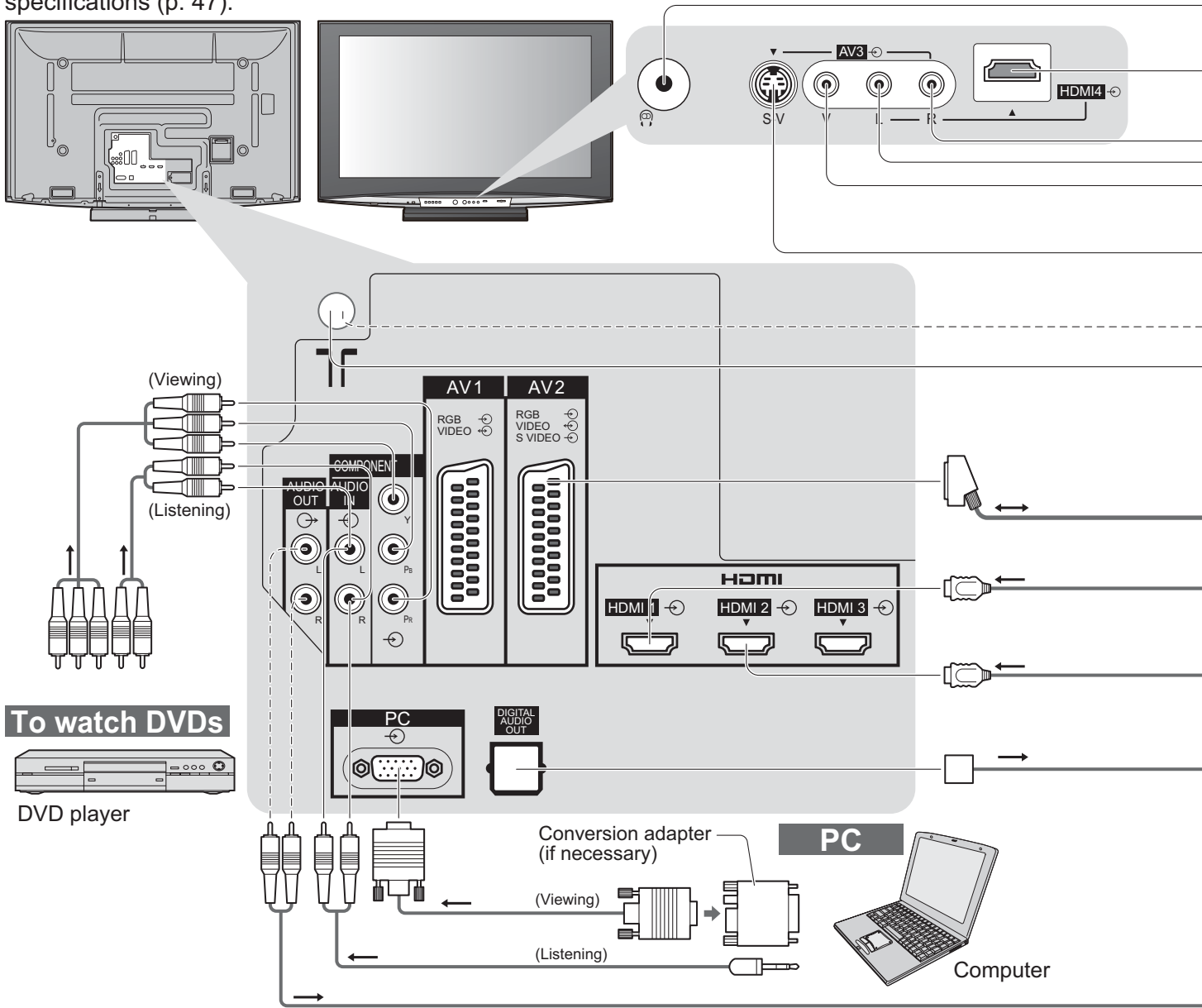

## Types of connectable equipment to each terminal

Terminal	AV1	AV2	AV3 (Front of TV)
Recording / Playback (equipment)			
To record / playback videocassettes / DVDs (VCR / DVD recorder)	○	○	
To watch DVDs (DVD player)	○	○	○
To watch camcorder images (Video camera)	○	○	○
To watch satellite broadcasts (Set top box)	○	○	○
To play games (Game equipment)	○	○	○
To use amplifier with speaker system			
Q-Link	○	○	
VIERA Link	○ (with HDMI)	○ (with HDMI)	
Direct TV Recording	○	○	

○: Recommended Connection

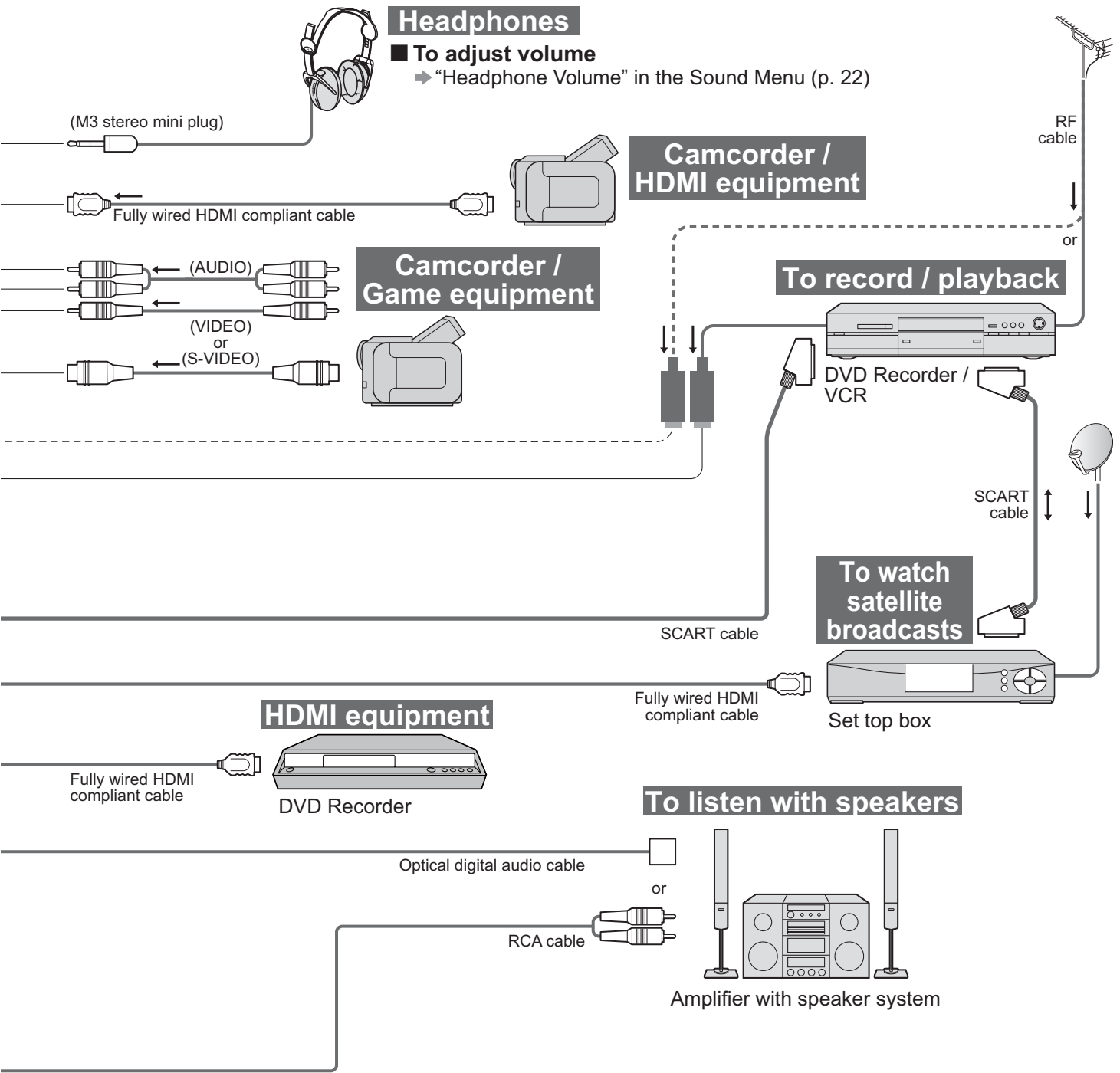

COMPONENT	AUDIO OUT	DIGITAL AUDIO OUT	HDMI			
			1	2	3	4
			<input type="checkbox"/>	<input type="checkbox"/>	<input type="checkbox"/>	<input type="checkbox"/>
<input type="checkbox"/>			<input type="checkbox"/>	<input type="checkbox"/>	<input type="checkbox"/>	<input type="checkbox"/>
	<input type="checkbox"/>	<input type="checkbox"/>				
			<input type="checkbox"/>	<input type="checkbox"/>	<input type="checkbox"/>	<input type="checkbox"/>
			<input type="checkbox"/>	<input type="checkbox"/>	<input type="checkbox"/>	<input type="checkbox"/>

# Technical Information

## Auto Aspect

The optimum size and aspect can be chosen, and you can enjoy finer images. (p. 15)

### ■ Auto

Auto aspect determines the best aspect ratio to use to fill your screen. It does this using a four step process to determine if the picture being viewed is a widescreen picture.

If Auto aspect detects a widescreen signal it switches into the appropriate 16:9 or 14:9 widescreen mode. If Auto aspect does not detect a widescreen signal then this advanced TV enhances the picture for optimum viewing pleasure.

The text shown on the screen indicates how Auto aspect determined which ratio to use:

“WIDE” appears in the top left of the screen if a widescreen identification signal (WSS) is found or a signal found through a SCART or HDMI terminal. Auto aspect switches to the appropriate 16:9 or 14:9 widescreen ratio. This function will also work in any aspect mode. “Auto” appears in the top left of the screen if black stripes above and below the picture are detected. Auto aspect chooses the best ratio and expands the picture to fill the screen.

This process can take several minutes, depending on the darkness of the picture.

Signal name	Aspect Control Signal										
	Widescreen signal (WSS)					Control signal through SCART (pin 8) or HDMI terminal					
	TV	AV1	AV2	AV3	COMPONENT	AV1	AV2	HDMI1	HDMI2	HDMI3	HDMI4
PAL	○	○	○	○		○	○				
PAL 525/60	—	—	—	—		○	○				
M.NTSC	—	—	—	—		○	○				
NTSC (AV input only)	—	—	—	—		○	○				
SD	525(480)/60i				—			○	○	○	○
	525(480)/60p				—			○	○	○	○
	625(576)/50i				○			○	○	○	○
	625(576)/50p				○			○	○	○	○
HD	750(720)/50p				—			○	○	○	○
	750(720)/60p				—			○	○	○	○
	1125(1080)/50i				—			○	○	○	○
	1125(1080)/60i				—			○	○	○	○
	1125(1080)/50p				—			○	○	○	○
	1125(1080)/60p				—			○	○	○	○
	1125(1080)/60p				—			○	○	○	○
	1125(1080)/24p				—			○	○	○	○

### Note

- The ratio varies depending on the programme, etc. If the ratio is greater than the standard “16:9”, black bands may appear at the top and bottom of the screen.
- If the screen size looks unusual when a widescreen-recorded programme is played back on a VCR, adjust the tracking of the VCR. (See the VCR manual.)

## HDMI connection

HDMI (high-definition multimedia interface) allows you to enjoy high-definition digital images and high-quality sound by connecting the TV and the equipment.

HDMI-compatible equipment (\*1) with an HDMI or DVI output terminal, such as a set top box or a DVD player, can be connected to the HDMI terminal using an HDMI compliant (fully wired) cable.

About connections, see “External Equipment” (p. 40).

### Note

- HDMI is the world’s first complete digital consumer AV interface complying with a non-compression standard.
- If the external equipment has only a DVI output, connect to the HDMI1 / 4 terminal via a DVI to HDMI adapter cable (\*2).
- When the DVI to HDMI adapter cable is used, connect the audio cable to the audio input terminal (HDMI1: use COMPONENT-AUDIO terminals / HDMI4: use AV3 audio terminals).
- Audio settings can be made on the “HDMI1 / 4 Input” menu screen. (p. 22)
- Applicable audio signal sampling frequencies (2ch L.PCM): 48 kHz, 44.1 kHz, 32 kHz
- HDMI2 and HDMI3 terminals are for digital audio signal only.
- Use with a PC is not assumed.
- If the connected equipment has an aspect adjustment function, set the aspect ratio to “16:9”.
- These HDMI connectors are “type A”.
- These HDMI connectors are compatible with HDCP (High-Bandwidth Digital Content Protection) copyright protection.
- An equipment having no digital output terminal may be connected to the input terminal of either “COMPONENT”, “S-VIDEO”, or “VIDEO” to receive analogue signals.
- The HDMI input terminal can be used with only the following image signals: 480i, 480p, 576i, 576p, 720p, 1080i and 1080p. Match the output setting of the digital equipment.
- For details of the applicable HDMI signals, see p. 44.
- This TV incorporates HDMI™ (Version 1.3 with Deep Colour, x.v.Color™) technology.

(\*1): The HDMI logo is displayed on HDMI-compliant equipment.

(\*2): Enquire at your local digital equipment retailer shop.

## SD Card

### ■ Cautions in handling SD Card

- Do not remove the card while the TV is accessing data (this can damage card or TV).
- Do not touch the pins on the back of the card.
- Do not subject the card to a high pressure or impact.
- Insert the card in the correct direction (otherwise, card may be damaged).
- Electrical interference, static electricity, or erroneous operation may damage the data or card.
- Back up the recorded data at regular intervals in case of deteriorated or damaged data or erratic operation of the TV. (Panasonic is not liable for any deterioration or damage of recorded data.)

### ■ Data format for Card browsing

Photo : Still images recorded with digital still cameras compatible with JPEG files of DCF\* and EXIF standards  
 Data format - Baseline JPEG (Sub-sampling 4:4:4, 4:2:2 or 4:2:0)  
 Max. number of files - 9,999  
 Image resolution - 160 × 120 to 10,000,000

Movie : SD-Video Standard Ver. 1.2 [MPEG-2 (PS format)] and AVCHD Standard compatible files with an audio format that is either MPEG-1/Layer-2 format or Dolby Digital format  
 (A modified data with a PC may not be displayed correctly.)

- Compliant card type (maximum capacity): SDHC Card (32 GB), SD Card (2 GB), Multi Media Card (128 MB), miniSD Card (1 GB) (requiring miniSD adapter)
- If miniSD Card is used, insert / remove it together with the adapter.
- Check the latest information on the card type at the following website. (English only)  
<http://panasonic.co.jp/pavc/global/cs/>

\*DCF (Design rule for camera file system): Unified standard established by Japan Electronics and Information Technology Industries Association (JEITA).

### Note

- Format the card with the recording equipment.
- The picture may not appear correctly on this TV depending on the recording equipment used.
- Display may take some time when there are many files and folders.
- This function cannot display Motion JPEG and still image not DCF formatted (i.e. TIFF, BMP).
- A data modified with a PC may not be displayed.
- Images imported from a PC must be compatible with EXIF (Exchangeable Image File) 2.0, 2.1, and 2.2.
- Partly degraded files might be displayed at a reduced resolution.
- All ".JPG" extension datas in the card will be read in Photo View Mode.
- The folder and file names may be different depending on the digital camera used.
- Do not use two-byte characters or other special codes.
- The card may become unusable with this TV if the file or folder names are changed.

### ■ On screen messages

Message	Meaning / Action
Cannot read file	<ul style="list-style-type: none"> <li>● The file is broken or unreadable.</li> <li>● The TV does not support the format. (For the applicable formats and data, see above.)</li> </ul>
Confirm SD card	<ul style="list-style-type: none"> <li>● The inserted SD card has a problem.</li> </ul>
Is SD Card in?	<ul style="list-style-type: none"> <li>● Insert a SD Card.</li> </ul>
No valid file to play	<ul style="list-style-type: none"> <li>● The card has no data.</li> </ul>
Over 9999 pictures found	<ul style="list-style-type: none"> <li>● Maximum valid number of photos is 9,999.</li> </ul>
This operation is not possible	<ul style="list-style-type: none"> <li>● Your operation is not available.</li> </ul>

## SCART, S-VIDEO and HDMI terminal information

### ■ AV1 SCART terminal (RGB, VIDEO, Q-Link)

Suitable inputs for AV1 include RGB (Red / Green / Blue).

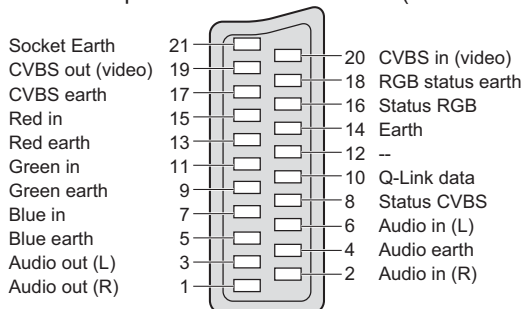

### ■ AV2 SCART terminal (RGB, VIDEO, S-VIDEO, Q-Link)

AV2 - Pins 15 and 20 are dependent on AV2 S-VHS / VIDEO switching.

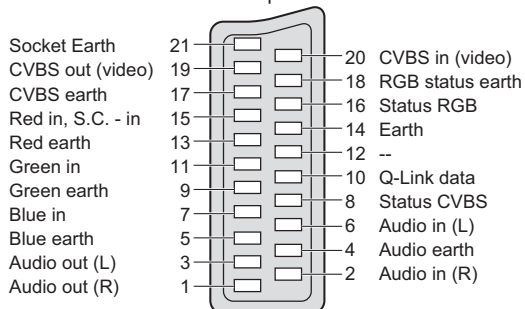

### ■ AV3 S-VIDEO 4 pin terminal

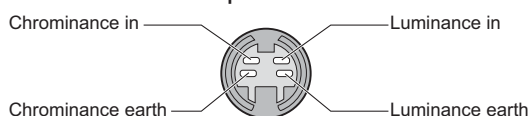

### ■ HDMI terminal

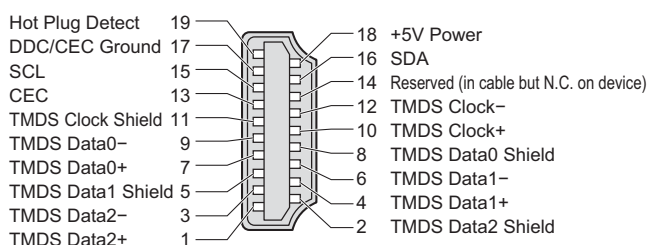

# Technical Information

## PC connection

A PC may be connected to this TV so that the PC screen is displayed and sound is heard from the TV.

- PC signals that can be inputted: Horizontal scanning frequency 31 to 69 kHz; vertical scanning frequency 59 to 86 Hz (more than 1,024 signal lines could result in incorrect display of the image).
- A PC adapter is not necessary for the DOS/V-compliant D-sub 15-pin connector.

### Note

- Some PC models cannot be connected to this TV.
- When using PC, set the colour display quality of PC to the highest position.
- For details of the applicable PC signals, see below.
- Max. display resolution

Aspect	4:3	1,440 × 1,080 pixels
	16:9	1,920 × 1,080 pixels

- D-sub 15-pin connector signal

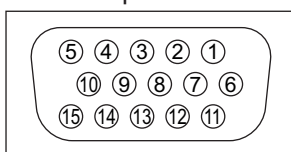

Pin No.	Signal Name	Pin No.	Signal Name	Pin No.	Signal Name
①	R	⑥	GND (Ground)	⑪	NC (not connected)
②	G	⑦	GND (Ground)	⑫	NC (not connected)
③	B	⑧	GND (Ground)	⑬	HD
④	NC (not connected)	⑨	NC (not connected)	⑭	VD
⑤	GND (Ground)	⑩	GND (Ground)	⑮	NC (not connected)

## Input signal that can be displayed

### COMPONENT (Y, P<sub>B</sub>, P<sub>R</sub>), HDMI

\* Mark: Applicable input signal

Signal name	COMPONENT	HDMI
525 (480) / 60i	*	*
525 (480) / 60p	*	*
625 (576) / 50i	*	*
625 (576) / 50p	*	*
750 (720) / 60p	*	*
750 (720) / 50p	*	*
1,125 (1,080) / 60i	*	*
1,125 (1,080) / 50i	*	*
1,125 (1,080) / 60p		*
1,125 (1,080) / 50p		*
1,125 (1,080) / 24p		*

### PC (D-sub 15P)

Signal name	Horizontal frequency (kHz)	Vertical frequency (Hz)
640 × 400 @70 Hz	31.47	70.07
640 × 480 @60 Hz	31.47	59.94
640 × 480 @75 Hz	37.50	75.00
800 × 600 @60 Hz	37.88	60.32
800 × 600 @75 Hz	46.88	75.00
800 × 600 @85 Hz	53.67	85.06
852 × 480 @60 Hz	31.44	59.89
1,024 × 768 @60 Hz	48.36	60.00
1,024 × 768 @70 Hz	56.48	70.07
1,024 × 768 @75 Hz	60.02	75.03
1,024 × 768 @85 Hz	68.68	85.00
1,280 × 1,024 @60 Hz	63.98	60.02
1,366 × 768 @60 Hz	48.39	60.04
Macintosh13" (640 × 480)	35.00	66.67
Macintosh16" (832 × 624)	49.73	74.55
Macintosh21" (1,152 × 870)	68.68	75.06

### Note

- Signals other than above may not be displayed properly.
- The above signals are reformatted for optimal viewing on your display.
- Applicable input signal for PC is basically compatible to VESA standard timing.
- PC signal is magnified or compressed for display, so that it may not be possible to show fine detail with sufficient clarity.

# FAQs

Before requesting service or assistance, please follow these simple guides to resolve the problem. If the problem still persists, please contact your local Panasonic dealer for assistance.

## White spots or shadow images (noise)

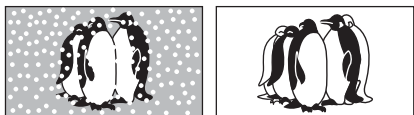

- Check the position, direction, and connection of the aerial.

## Neither image nor sound is produced

- Is the TV in "AV mode"?
- Is the mains lead plugged into the socket outlet?
- Is the TV turned On?
- Check Picture Menu (p. 22) and volume.
- Check all required SCART cables and connections are firmly in place.

## Auto aspect

- Auto aspect is designed to provide you with the best aspect ratio to use to fill your screen. For user control please see p. 42.

## S-Video / black and white picture

- Using AV button please confirm your selection is S-Video i.e. AV2/S (p. 18).

## On Screen messages - i.e. EC/AV1

- You can simply clear these →  Press again to redisplay.

## An error message appears

- Follow the message's instructions.
- If the problem persists, contact the authorized Service Centre.



## Q-Link function does not work

- Please confirm SCART cable and connection. Also please set "AV1 / AV2 out" in the Setup Menu (p. 23).

## "VIERA Link" function does not work and an error message appears

- Confirm the connection.
- Turn the connected equipment on and then switch the TV on. (p. 36)

## Recording does not start immediately

- Check the settings of the recorder. For details, read the manual of the recorder.

## Permanently lit spots on screen

- Due to production process involved in this technology this may result in some pixels which are permanently lit or unlit. This is not a malfunction.

## Contrast is reduced

- Contrast is lowered in the following conditions without any user operation for a few minutes:
  - no signal in AV mode
  - selected locked programme
  - selected invalid programme
  - displayed menu
  - Thumbnail, list or still picture in SD Card mode

# FAQs

	Problem	Actions
Screen	Chaotic image, noisy	<ul style="list-style-type: none"> <li>● Set "P-NR" in the Picture Menu (to remove noise). (p. 22)</li> <li>● Check nearby electrical products (car, motorcycle, fluorescent lamp).</li> </ul>
	No image can be displayed	<ul style="list-style-type: none"> <li>● Is "Colour" or "Contrast" in the Picture Menu set to the minimum? (p. 22)</li> <li>● Check Colour System. (p. 27)</li> </ul>
	Blurry or distorted image (no sound or low volume)	<ul style="list-style-type: none"> <li>● Reset programme. (p. 27)</li> </ul>
	Unusual image is displayed	<ul style="list-style-type: none"> <li>● Turn off the TV with Mains power On / Off switch, then turn it On again.</li> </ul>
Sound	No sound is produced	<ul style="list-style-type: none"> <li>● Is "Sound mute" active? (p. 9)</li> <li>● Is the volume set to the minimum?</li> </ul>
	Sound level is low or sound is distorted	<ul style="list-style-type: none"> <li>● Sound signal reception may be deteriorated.</li> <li>● Set "MPX" (p. 22) in the Sound Menu to "Mono".</li> </ul>
	Whirling sound is heard	<ul style="list-style-type: none"> <li>● The sound is from built-in cooling fan (not a sign of faulty operation).</li> </ul>
HDMI	Sound is unusual	<ul style="list-style-type: none"> <li>● Set the sound setting of the connected equipment to "2ch L.PCM".</li> <li>● Check the "HDMI1 / 4 Input" setting in the Sound Menu. (p. 22)</li> <li>● If digital sound connection has a problem, select analogue sound connection. (p. 42)</li> </ul>
	Pictures from external equipment are unusual when the equipment is connected via HDMI	<ul style="list-style-type: none"> <li>● Is the HDMI cable connected properly? (p. 40)</li> <li>● Turn Off the TV and equipment, then turn them On again.</li> <li>● Check an input signal from the equipment. (p. 44)</li> <li>● Use an equipment compliant with EIA/CEA-861/861B.</li> </ul>
Other	TV goes into "Standby mode"	<ul style="list-style-type: none"> <li>● Off Timer function is activated.</li> <li>● The TV enters "Standby mode" about 30 mins. after broadcasting ends.</li> </ul>
	The remote control does not work	<ul style="list-style-type: none"> <li>● Are the batteries installed correctly? (p. 6)</li> <li>● Has the TV been switched On?</li> </ul>



## Information on Disposal for Users of Waste Electrical & Electronic Equipment (private households)



This symbol on the products and/or accompanying documents means that used electrical and electronic products should not be mixed with general household waste.

For proper treatment, recovery and recycling, please take these products to designated collection points, where they will be accepted on a free of charge basis. Alternatively, in some countries you may be able to return your products to your local retailer upon the purchase of an equivalent new product.

Disposing of this product correctly will help to save valuable resources and prevent any potential negative effects on human health and the environment which could otherwise arise from inappropriate waste handling. Please contact your local authority for further details of your nearest designated collection point. Penalties may be applicable for incorrect disposal of this waste, in accordance with national legislation.

### For business users in the European Union

If you wish to discard electrical and electronic equipment, please contact your dealer or supplier for further information.

### Information on Disposal in other Countries outside the European Union

This symbol is only valid in the European Union.

If you wish to discard this product, please contact your local authorities or dealer and ask for the correct method of disposal.

# Licence

- VGA is a trademark of International Business Machines Corporation.
- Macintosh is a registered trademark of Apple Inc., USA.
- S-VGA is a registered trademark of the Video Electronics Standard Association.  
Even if no special notation has been made of company or product trademarks, these trademarks have been fully respected.
- SDHC Logo is a trademark.
- HDMI, the HDMI Logo and High-Definition Multimedia Interface are trademarks or registered trademarks of HDMI Licensing LLC.
- HDAVI Control™ is a trademark of Matsushita Electric Industrial Co., Ltd.
- "AVCHD" and the "AVCHD" logo are trademarks of Matsushita Electric Industrial Co., Ltd. and Sony Corporation.
- Manufactured under license from Dolby Laboratories.  
Dolby and the double-D symbol are trademarks of Dolby Laboratories.
- TruSurround XT, SRS and (●) symbol are trademarks of SRS Labs, Inc.  
TruSurround XT technology is incorporated under license from SRS Labs, Inc.

## Customer's Record

The model number and serial number of this product may be found on its rear panel. You should note this serial number in the space provided below and retain this book, plus your purchase receipt, as a permanent record of your purchase to aid in identification in the event of theft or loss, and for Warranty Service purposes.

Model Number

Serial Number

## Matsushita Electric Industrial Co., Ltd.

Web Site : <http://www.panasonic-europe.com>

© 2008 Matsushita Electric Industrial Co., Ltd. All Rights Reserved.