

Panasonic

High-Power CD Player/RDS Receiver

CQ-RDP212/RDP202N Operating Instructions

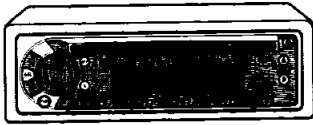

**Bedienungsanleitung
Manuel d'instructions
Gebruiksaanwijzing
Bruksanvisning
Manuale di istruzioni
Manual de Instrucciones**

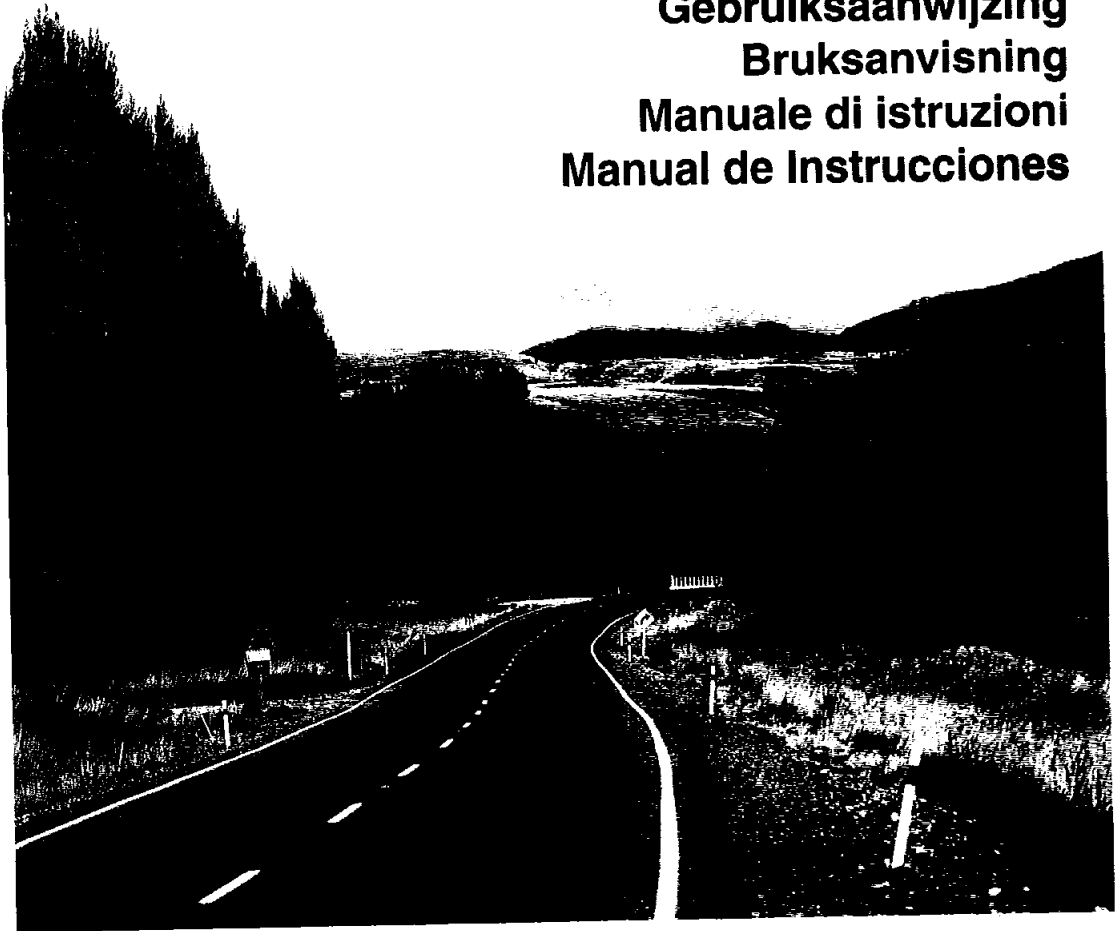

- Please read these instructions carefully before using this product and save this manual for future use.
- Bitte lesen Sie diese Bedienungsanleitung vor der Verwendung dieses Produktes aufmerksam durch und bewahren Sie sie danach für spätere Nachschlagzwecke sorgfältig auf.
- Prière de lire ces instructions attentivement avant d'utiliser le produit et garder ce manuel pour l'utilisation ultérieure.
- Leest u deze instructie alstublieft zorgvuldig door voor u dit product in gebruik neemt en bewaar deze handleiding voor later gebruik.
- Läs igenom denna bruksanvisning noga innan produkten tas i bruk. Spara bruksanvisningen för framtida behov.
- Si prega di leggere attentamente queste istruzioni prima di usare questo prodotto e di conservare questo manuale per usi futuri.
- Lea con atención estas instrucciones antes de utilizar el producto y guarde este manual para poderlo consultar en el futuro.

Label Indications and Their Locations
Warnetiketten und deren Anbringungsort
Indications portées les étiquettes et emplacement
Aanduiding van de labels en hun plaats
Varningsskyltarna, och deras placering
Indicazioni delle etichette e le loro posizioni
Indicaciones de las etiquetas y su ubicación

VORSICHT!
 UNSICHTBARE LASERSTRAHLUNG!
 WENN ABDECKUNG GEÖFFNET IST,
 NICHT DEM LASERSTRAHL AUSSETZEN.

- APPAREIL À LASER DE CLASSE 1
- KLASS 1 LASER APPARAT
- LUOKAN 1 LASERPLAITE

**CLASS 1
 LASER PRODUCT**

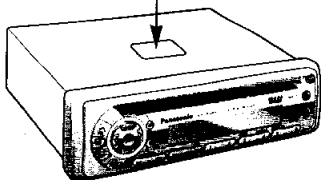

- Caution Mark
- Warnzeichen
- Marque d'avertissement
- Waarschuwingstekon
- Varningsmärke
- Marca di precauzione
- Marka de advertencia

DANGER! Invisible laser radiation when open.
 Avoid direct exposure to beam.

ADVARSEL! Usynligt laserlys udstråles ved åbning. Undgå direkte bestråling.

VARO! Avattaessa ja suojalukitus ohitettaessa olet alltiina näkymättömälle lasersäteilylle. Älä kasto säteeseen.

WARNING! Osynlig laserstråling når denna del är öppnad och spårren är urkopplad. Betrakta ej strålen.

ADVERSEL! Usynlig laserstråling når deksel åpnes og sikkerhedslås brytes. Unngå eksponering for strålen.

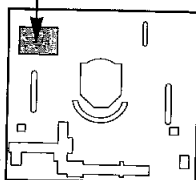

- Deck Ass'y (Upper Side)
- Geräteansicht (Oberseite)
- Assemblage de la table lecture (Côté supérieur)
- Dekkbevestig (Bovenkant)
- Däcksenhät (Topp)
- Gruppo della piastra (Lato superiore)
- Conjunto de la platina (Lado superior)

Contents

	Page
Precautions (ISO Connector)	4
Precautions	6
Laser Products	6
Power and Sound Controls	7
Radio Basics	8

Inhaltsverzeichnis

	Seite
Vorsichtsmaßnahmen (ISO-Stecker)	4
Vorsichtsmaßnahmen	24
Laserprodukte	24
Stromversorgung und Klangregler	25
Rundfunkempfang	26

Table des matières

	Page
Mesures de précaution (connecteur ISO)	4
Mesures de précaution	42
Appareils à laser	42
Interrupteur d'alimentation et commandes de réglage de la sonorité	43

Inhoudsopgave

	Bladzijde
Voorzorgsmaatregelen (ISO aansluiting)	4
Voorzorgen	60
Laserproducten	60
Stroomvoorziening en geluidsregeling	61
Basisbediening radio	62

Innehåll

	Sida
Observera (ISO-kontakt)	4
Observera	78
Om laserprodukter	78
Ström- och ljudreglage	79
Grundläggande manövrering av radion	80

Contenuto

	Pag.
Precauzioni (Connettore ISO)	4
Precauzioni	96
Prodotti laser	96
Comandi di alimentazione e del suono	97
Funzionamento della radio	98

Indice

	Pag.
Precauciones (conector ISO)	4
Precauciones	114
Productos láser	114
Alimentación y controles del sonido	115
Operación básica de la radio	116

RDS (Radio Data System)	10	Speaker Connections	22
CD Player	14	Fuse	22
Installation	16	Maintenance	22
Anti-Theft System	19	Specifications	23
Electrical Connections	20		

Radio-Daten-System (RDS)-Empfang	28	Anschluß der Lautsprecher	40
CD-Spieler	32	Sicherung	40
Einbau	34	Pflege	40
Diebstahlschutz	37	Technische Daten	41
Elektrischer Anschluß	38		

Utilisation de base du récepteur radio	44	Branchements électriques	56
Réception radio RDS (Radio Data System)	46	Branchement des haut-parleurs	58
Utilisation du lecteur de disque compact	50	Fusible	58
Installation	52	Entretien	58
Système antivol	55	Données techniques	59

RDS (Radio Data System)	64	Aansluitingen luidsprekers	76
CD-speler	68	Zekering	76
Installatie	70	Onderhoud	76
Anti-diefstal systeem	73	Technische gegevens	77
Elektrische aansluitingen	74		

RDS-mottagning (datastyrd radiomottagning) ..	82	Anslutning av högtalare	94
CD-spelare	86	Säkring	94
Montering	88	Underhåll	94
Stölskyddsanordning	91	Tekniska data	95
Elektriska anslutningar	92		

Ricezione RDS (Radio Data System)	100	Collegamenti degli altoparlanti	112
Lettore CD	104	Fusibile	112
Installazione	106	Manutenzione	112
Sistema antifurto	109	Dati tecnici	113
Collegamenti elettrici	110		

Recepción RDS (sistema de datos radiofónicos)	118	Conexiones eléctricas	128
Reproductor de CD	122	Conexiones de los altavoces	130
Instalación	124	Fusible	130
Sistema antirrobo	127	Mantenimiento	130
		Especificaciones	131

Precautions (ISO Connector)

- The pin arrangement of the power connector conforms to ISO standard.
- The pin arrangement of ISO connectors in some cars may differ from the ISO standard.
- Please check that the pin arrangement of the connector in your car conforms to ISO standard.
- For car types A and B, change the wiring of the red and yellow leads as shown at right.
- After connection, insulate the portions marked (*) with insulating tape.

Note : For cars other than types A and B, please consult your local car shop.

Vorsichtsmaßnahmen (ISO-Stecker)

- Die Stiftanordnung des Versorgungssteckers entspricht dem ISO-Standard.
- Die Stiftanordnung der ISO-Stecker im manchen Fahrzeugen kann von dem ISO-Standard abweichen.
- Bitte stellen Sie sicher, daß die Stiftanordnung des Steckers in Ihrem Fahrzeug dem ISO-Standard entspricht.
- Im Falle der Anordnung für Auto A oder B die Anschlüsse der rot/gelben Kabel am Übertragungs-Steckverbinderblock (*).
- Nach der Verkabelung sollte unbedingt der durch * gekennzeichnete Teil mit Hilfe von Isolierbändern o.ä. isoliert werden.

Hinweis: Für andere als die Fahrzeugtypen A und B wenden Sie sich bitte an Ihre örtliche Werkstatt.

Mesures de précaution (connecteur ISO)

- La disposition des broches du connecteur d'alimentation est conforme aux normes ISO.
- La disposition des broches des connecteurs ISO de certaines voitures risque d'être différente par rapport aux normes ISO.
- Vérifier si la disposition des broches du connecteur de votre voiture est conforme aux normes ISO.
- En ce qui concerne les véhicules des types A et B, modifier le câblage des fils rouge et jaune comme indiqué ci-contre.
- Une fois le branchement réalisé, isoler les sections identifiées par le signe (*) avec de l'adhésif isolant.

Remarque : En ce qui concerne les véhicules des types A et B, veuillez vous renseigner auprès de votre concessionnaire automobile habituel.

Voorzorgsmaatregelen (ISO aansluiting)

- De pennen van de stroomaansluiting voldoen aan de vereisten van de ISO standaard.
- De pennen van ISO aansluitingen in sommige auto's kunnen verschillen van de ISO standaard.
- Controleer of de pennen van de aansluiting in uw auto voldoen aan de ISO standaard.
- Voor auto's van de types A en B dienen de rode en gele draden gewijzigd te worden zoals rechts staat aangegeven.
- Na het aansluiten moeten de plekken die zijn aangegeven met (*) afgeplakt worden met isolatieband.

Opmerking: voor auto's van andere types dan A en B dient u uw plaatselijke garage te raadplegen.

Observera (ISO-kontakt)

- Stiftens placering i strömkontakten överensstämmer med ISO-standard.
- I vissa bilar kan stiftens placering i ISO-kontakter skilja sig från ISO-standard.
- Kontrollera att stiftens placering i kontakten på din bil överensstämmer med ISO-standard.
- För biltyp A och B: ändra ledningsdragningen av de röda och gula kablarna så som visas till höger.
- Delar märkta med (*) måste efter slutförda anslutningar isoleras med isoleringstejp.

Obs: Kontakta din lokala bilhandlare i fråga om bilar av annan typ än A och B.

Precauzioni (Connettore ISO)

- La disposizione dei pin del connettore di alimentazione è conforme allo standard ISO.
- La disposizione dei pin dei connettori ISO in alcune automobili potrebbe differire dallo standard ISO.
- Accertarsi che la disposizione dei pin del connettore dell'automobile sia conforme allo standard INSTALLATO.
- Per le macchine del tipo A e B, cambiare i collegamenti dei cavi rosso e giallo come mostrato a destra.
- Dopo il collegamento, isolare le parti contrassegnate collegare (*) usando del nastro isolante.

Nota: Per le macchine diverse dal tipo A e B, rivolgersi a una autorivendita locale.

Precauciones (conector ISO)

- La disposición de las patillas del conector de alimentación satisface las normas ISO.
- La disposición de las patillas de los conectores ISO de algunos vehículos puede ser distinta de las normas ISO.
- Compruebe que la disposición de las patillas del conector de su vehículo satisfaga las normas ISO.
- Para los tipos A y B de vehículos, cambie las conexiones de los cables rojo y amarillo como se muestra a la derecha.
- Después de la conexión, aisle las partes marcadas con (*) usando cinta aislante.

Nota: Para los vehículos que no sean de los tipos A y B, consulte a su taller mecánico local.



Standard ISO

- IGN or ACC switched 12V supply
- Zündschalter (ACC/IGN)
- Sélecteur ACC/IGN
- ACC/IGN schakelaar
- tändningsomkopplare
- Interruttore ACC/IGN
- Llave ACC/IGN
- +12 V Battery (Permanent supply)
- +12 V-Batterie
- Batterie +12 V
- +12 V accu
- +12 V batteri
- Batterie +12 V
- +12 V Batería

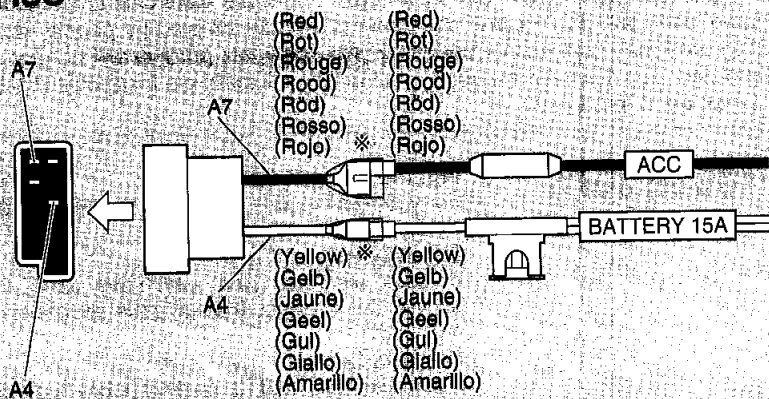

Car Type A

- +12 V Battery (Permanent supply)
- +12 V-Batterie
- Batterie +12 V
- +12 V accu
- +12 V batteri
- Batterie +12 V
- +12 V Batería
- IGN or ACC switched 12V supply
- Zündschalter (ACC/IGN)
- Sélecteur ACC/IGN
- ACC/IGN schakelaar
- tändningsomkopplare
- Interruttore ACC/IGN
- Llave ACC/IGN

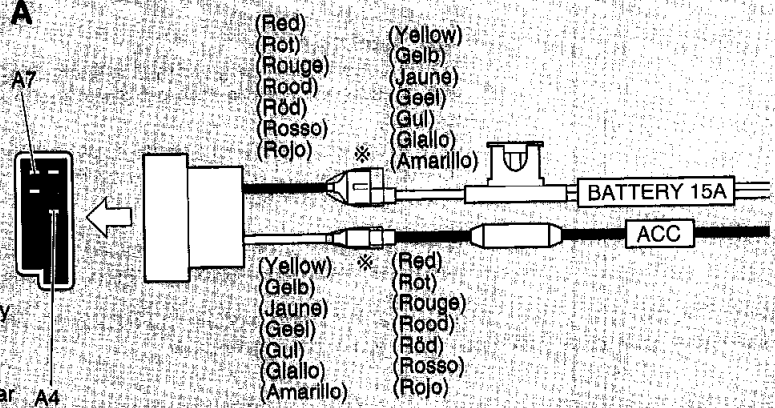

Car Type B

- +12 V Battery (Permanent supply)
- +12 V-Batterie
- Batterie +12 V
- +12 V accu
- +12 V batteri
- Batterie +12 V
- +12 V Batería
- No connection
- Kein Anschluß
- Non connecté
- Niet aangesloten
- ingen aansluiting
- Non collegato
- Sin conexión

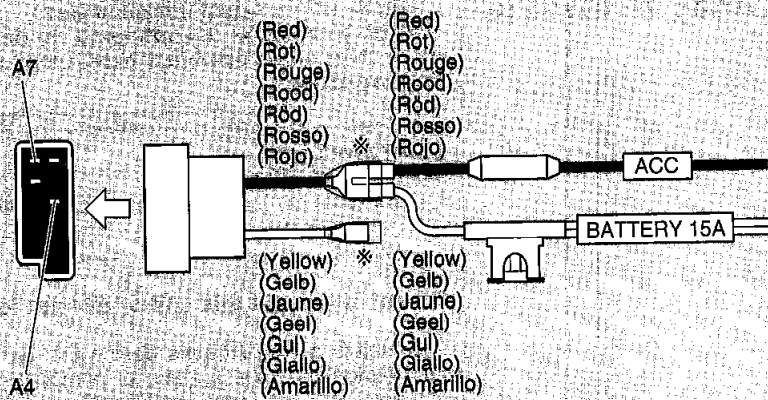

Panasonic welcomes you to their constantly growing family of electronic products owners. We endeavor to give you the advantages of precise electronic and mechanical engineering, manufactured with carefully selected components, and assembled by people who are proud of the reputation their work has built for our company. We know this product will bring you many hours of enjoyment, and after you discover the quality, value and reliability we have built into it, you too will be proud to be a member of our family.

Precautions

Volume Level

For your driving safety, keep the volume level low enough to be aware of road and traffic conditions.

Car Washing

To avoid electrical shorts which may cause fire, or other damage, do not expose this Product (including the speakers and CDs) to water or excessive moisture.

Car Ventilation

If your car is parked for several hours in direct sunlight, the temperature inside the car may become very high. It is advisable to drive the car and give the interior a chance to cool down before switching the unit on.

Power Supply

This Product is designed to be used in a car having a 12-Volt negative ground battery system.

Disc Mechanism

Do not insert coins or any small objects. Keep screwdrivers and other metallic objects away from the disc mechanism and disc.

Service

This Product is made of precision parts. Do not attempt to disassemble or adjust any parts. For repair, please consult your nearest authorized Panasonic Service Center.

Note: The preset memory is cleared to return to the original factory setting when the power connector or battery is disconnected.

Note: This operating instruction manual is for two models CQ-RDP212N and CQ-RDP202N. The differences among these models' are mentioned below.

Features \ Model	CQ-RDP212N	CQ-RDP202N
Illumination Colors	Amber	Green

Laser Products

Caution: This product utilizes a laser. Use of controls or adjustments or performance of procedures other than those specified herein may result in hazardous radiation exposure.

Laser products:
Wave Length 780 nm
Laser Power No hazardous radiation is emitted with safety protection.

Do not take apart this unit or attempt to make any changes yourself.

This unit is a very intricate device that uses a laser pickup to retrieve information from the surface of compact discs. The laser is carefully shielded so that its rays remain inside the cabinet. Therefore, never try to disassemble the player or alter any of its parts since you may be exposed to laser rays and dangerous voltages.

Power and Sound Controls

Power

Turn the key in the ignition until the accessory indicator lights.

Power on : Press **[PWR]**.

Power off : Press **[PWR]** again and hold.

The panel removal alarm sounds. (➔ Page 19).



Note : When the power is switched on for the first time, a demonstration message appears on the display. **To cancel this display, press [D] (DISP/CT).**

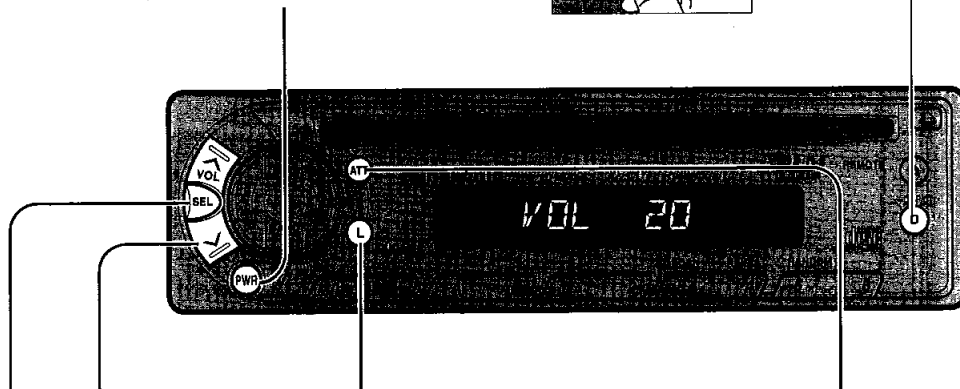

Volume

[^VOL] : Up

[vVOL] : Down

Press and hold for rapid adjustment.



Volume Level (0 to 40)

Anti-Volume-Blast Circuit

When the power is switched off and on again, the volume slowly rises to the previous level.

Loudness

Press **[L]** (LOUD) to enhance bass and treble tones at low or medium volume.

Press **[L]** (LOUD) again to cancel.



Attenuator

Press **[ATT]** to decrease volume to about 1/10 of the previous level.

Press **[ATT]** again to cancel.



Audio Mode (Bass/Treble/Balance/Fader)

➊ Press **[SEL]** to select the audio mode. Modes change as follows:

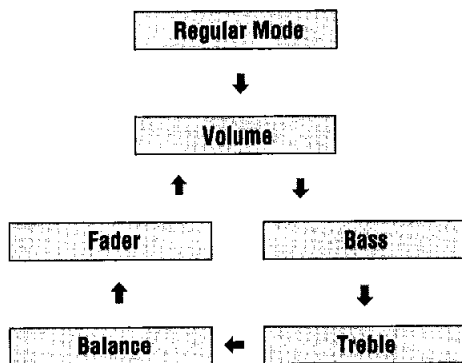

➋ Press **[^VOL]** or **[vVOL]** to change each level.

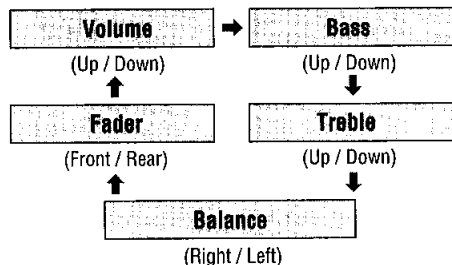

Note: If no operation takes place for more than 5 seconds in audio mode (2 seconds in Volume mode), the display return to Regular Mode.

Radio Basics

1 Mode Selection

Press [MODE] to change to the radio mode.

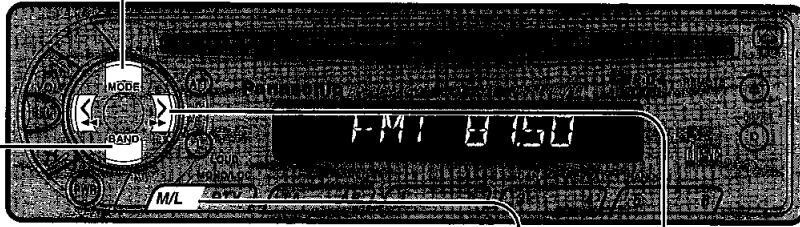
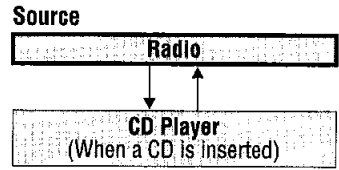

2 Band

Press [BAND] to change the bands.

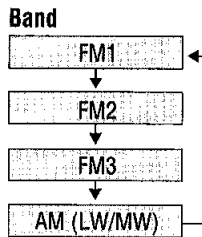

3 Manual Tuning

[>]: Higher frequency.
[<]: Lower frequency.

Seek Tuning

Press and hold [>] or [<] for more than 0.5 seconds, then release. Seeking will start.

4 Mono/Local Selection

MONO : Monaural reception. Select MONO to reduce noise when receiving a stereo broadcast.

LOCAL : Tunes in strong stations only.

FM broadcasts

Press and hold [M/L] (MONO/LOC) to change the mode. Release when at the desired point.

AM broadcast

Press [M/L] (MONO/LOC) to switch LOCAL mode on and off.

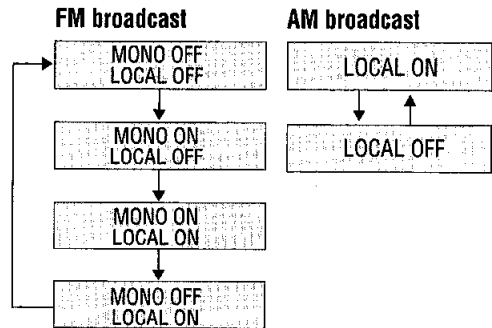

Preset Station Setting

Up to 6 stations each can be saved in the FM1, FM2, FM3 and AM (LW/MW) preset station memories.

Caution: To ensure safety, never attempt to preset stations while you are driving.

1 Band

Select a band.
(→ Page 8)



Band

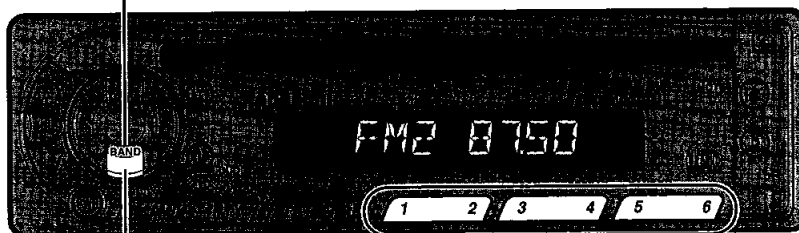

2 Auto Station Preset

Press and hold **[BAND]** (AUTO•P) for more than 2 seconds (Auto Preset Memory).

- The 6 strongest available stations will be automatically saved in the memory under preset buttons **[1]** to **[6]**.
- Once set, the preset stations are sequentially scanned for 5 seconds each.

Manual Station Preset

- (1) Use manual or seek tuning to find a station.
(→ Page 8)
- (2) Press and hold one of the preset buttons **[1]** to **[6]** until the display blinks once.



Band

Preset Number

3 Tuning in a Preset Station

Press the corresponding preset button **[1]** to **[6]** to tune in a preset station.

Note: You can change the memory presetting by repeating the above procedure.

RDS (Radio Data System)

RDS Basics

The following functions are available when receiving RDS stations.

PS Display

(Program Service Name)

The name of station is displayed instead of the frequency.

CT Service

(Clock Time)

When receiving an RDS station, the CT (Clock Time) service automatically adjusts the time and date. "NO CT" is displayed in areas where CT service is not available. (→ Page 13 for Clock Set)

AF

(Alternative Frequency)

When reception is poor, an RDS station broadcasting the same program is tuned in automatically.

AF Mode

Press [AF] to select one of the following AF modes:

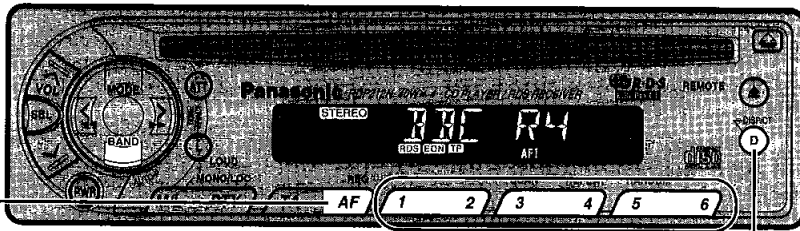
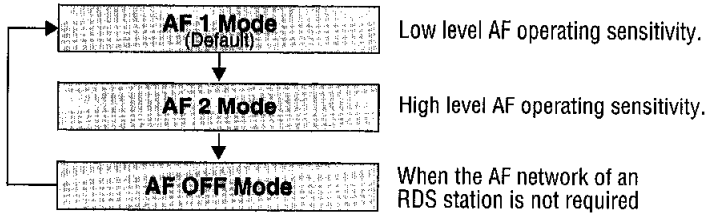

REG (Region) Mode

Changes the selection range of AF, Best Station Research and PI Seek.

Press and hold [AF] (REG) when AF mode is on.



The frequency is changed only for programs within the region.



The frequency is changed also for programs outside the region.

Auto Preset Memory

Auto preset memory works only for RDS stations when AF mode is on.

Best Station Research

Best Station Research is automatically activated to store the station with the best reception for each preset button.

PI (Program Identification) Seek

If Best Station Research does not work properly and reception is poor when tuning in a preset station, press the **same preset button again**. PI Seek will search an AF station with good reception.

Display Change

Press [D] (DISP/CT) to change the display as follows.

PS (Program Service Name)(Default)



Frequency



CT (Clock Time)



3 seconds

Traffic Announcements

Some RDS FM stations periodically provide traffic information.

TP
(Traffic Program)
Broadcasting of traffic information

TA
(Traffic Announcements)
Radio announcements on traffic conditions

TA Mode

Press [TA] to switch TA mode on and off.

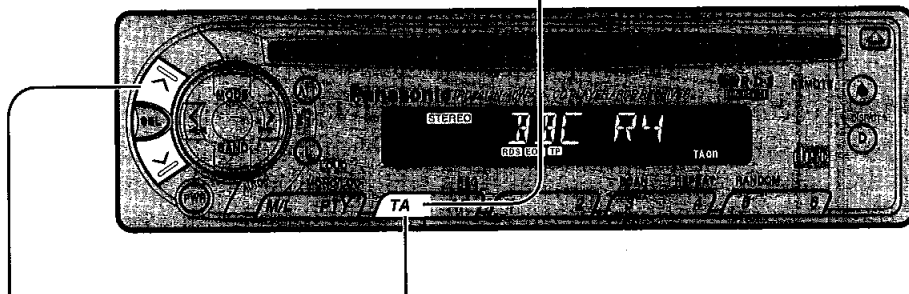
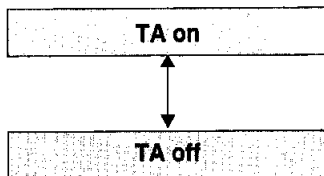

TA Volume Set (Volume Level : 0 to 40)

Press [∧VOL] or [∨VOL] while receiving traffic announcements. The TA volume differs from the regular volume (by up to 5 levels).

TA in CD Mode

When TA is on, CD playback will be interrupted by FM traffic announcements.



Information ↑↓ End



Muting in TA Mode

To listen only to Traffic Announcements while muting, press and hold [TA] for more than 2 seconds.

To cancel the muting TA on mode (muting in TA mode → TA mode), take either following two.

- Press [TA] again.
- Press [∧VOL] several times.

Note : To switch to TA off, press [TA] again and hold for more than 2 seconds.

TP Auto Search

When reception of a TP station is poor, TP Auto Search will automatically search for a TP station with better reception.

Seek and Preset Station

TP Seek Tuning

Seek tunes only TP stations.

(⇒ Page 8)

Auto TP Station Preset

The 6 strongest TP stations are saved in memory.

(⇒ Page 9)

Tuning in a TP Preset Station

(⇒ Page 9)

RDS (Radio Data System) (continued)

PTY Reception (Program Type)

RDS FM stations provide a program type identification signal.
Example: news, rock, classical music, etc.

PTY Mode

Press [PTY] to switch PTY display mode on or off.

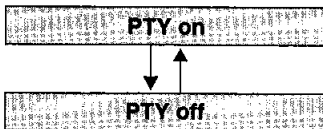

When there is no corresponding program type, "NO PTY" is display

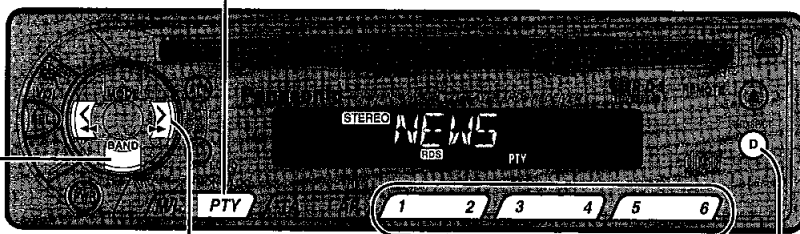

PTY Selection

1 Press [>] to change the program type as follows. ([<]: opposite direction)

- | | | | | | | | |
|----------|---|----------|---|----------|---|----------|---|
| SPEECH | → | MUSIC | → | NEWS | → | AFFAIRS | → |
| INFO | → | SPORT | → | EDUCATE | → | DRAMA | → |
| CULTURES | → | SCIENCE | → | VARIED | → | POP M | → |
| ROCK M | → | M.O.R.M | → | LIGHT M | → | CLASSICS | → |
| OTHER M | → | WEATHER | → | FINANCE | → | CHILDREN | → |
| SOCIAL A | → | RELIGION | → | PHONE IN | → | TRAVEL | → |
| LEISURE | → | JAZZ | → | COUNTRY | → | NATIONAL | → |
| OLDIES | → | FOLK M | → | DOCUMENT | → | SPEECH | |

2 Select the desired program and press [BAND]. Seek will start to tune in to a station broadcasting the selected program type.

PTY display in Swedish

Press [D] (DISP/CT) to switch the PTY display language as follows.



PTY Search

1 Select a program type by pressing the preset button. The preset program type appears on the display for 5 seconds.

Example: Press preset button [1].



2 Press the same preset button again (or press [BAND]) to tune in the desired program type station.

Example: Press preset button [1] again.



PTY Preset Change

1 Select a program type by using PTY Selection or pressing PTY Preset buttons.



2 Press and hold one of the buttons [1] to [6].
Example: Press and hold preset button [2].



PTY Preset

Program types are stored in memory under preset buttons [1] to [6] shown in the table below. To tune in the desired program type, press any of preset buttons [1] to [6].

Preset No.	Program Type	Display	
1	News	NEWS	NEWS
2	Speech	SPEECH	AFFAIRS / INFO EDUCATE / DRAMA CULTURES / SCIENCE VARIED / WEATHER FINANCE / CHILDREN SOCIAL A / RELIGION PHONE IN / TRAVEL LEISURE / DOCUMENT
3	Sport	SPORT	SPORT
4	Pop. Music	POP	POP.M
5	Classic Music	CLASSICS	CLASSICS
6	Other Music	MUSIC	ROCK M / M.O.R.M LIGHT M / OTHER M JAZZ / COUNTRY NATIONAL / OLDIES FOLK M

EON (Enhanced Other Networks)

When EON data is received, the EON indicator lights and the TA and AF functions are expanded as follows.

TA : Traffic information from the current and other network stations can be received.

AF : The frequency list of preset RDS stations is updated by EON data.

EON enables the radio to make fuller use of RDS information. It constantly updates the AF list of preset stations, including that currently tuned in to. For example, if you preset a station far from home, you will later be able to receive the same station at an alternative frequency, or any other station serving the same program. EON also keeps track of locally available TP stations for quick reception.

Emergency Announcement Reception

When an emergency announcement is broadcast, the unit is automatically switched to receiving that broadcast. If this happens in CD mode or in Muting in TA mode, "ALARM" blinks on the display.

Clock Set

When RDS CT service is not available, set the clock as follows.

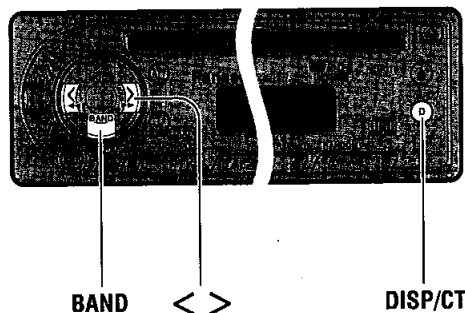

AM Band

- Press [BAND] to change to AM band.

AM 1305 (AM band)

- Press [D] (DISP/CT)

NO CT (Clock Display)

Hours

- Press and hold [D] (DISP/CT)

ET 10:00 (hour blinks)

- Press [>] or [<]

ET 10:00 (hour set)

Minutes

- Press [D] (DISP/CT)

ET 10:00 (minute blinks)

- Press [>] or [<]

ET 10:35 (minute set)

- Press [D] (DISP/CT)

ET 10:35 (end)

Note : Hold [>] or [<] to change numbers rapidly.

CD Player

Disc Insert and Playback

Insert a disc.

Play back will start automatically.

Stop and Disc Eject.

Press [▲] to stop CD play and eject the disc.

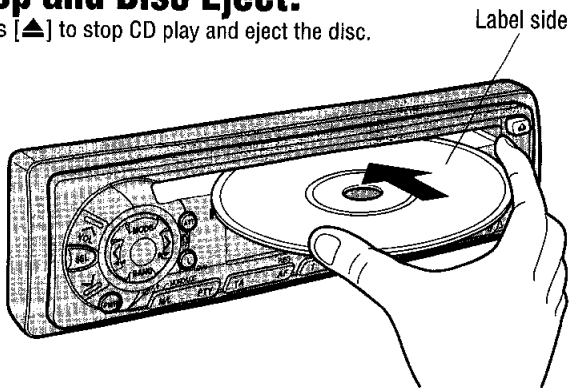

Caution: Only 12cm CD is available for this unit.

ONLY USE DISCS CARRYING THE LABEL SHOWN ON THE RIGHT



How to hold the CD

- Do not touch the underside of the disc.
- Do not make scratches on the disc.
- Do not bend disc.
- When not in use, keep CD in the case.

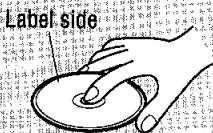

Do not use irregularly shaped CDs

Heart-Shaped



Octagon



Do not leave discs in the following places:

- Direct sunlight
- Dirty, dusty and damp area
- Near car heaters
- Seats and dashboards

Disc Cleaning

Use a dry, soft cloth to wipe from the center outward.



Caution on New Discs

A new disc may have rough edges on its inner and outer perimeter. These may cause malfunction.

Remove the rough edges using a pencil, etc.

Rough edge

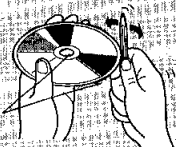

Listening to a CD

Mode Selection

Press [SOURCE] to change to the CD mode.

Source

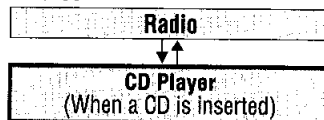

Track Selection

- [▶▶TRACK]: Advance to the next track.
- [◀◀TRACK]: Back to beginning of the current track.
- Back to previous track. (Press twice)

Track Search

Press and hold

- [▶▶TRACK]: Fast forward
- [◀◀TRACK]: Fast backward
- Release to resume the regular CD play.

Random Play

Scan Play

Repeat Play

Note : The CD changer functions are designed for an optional CD changer unit.

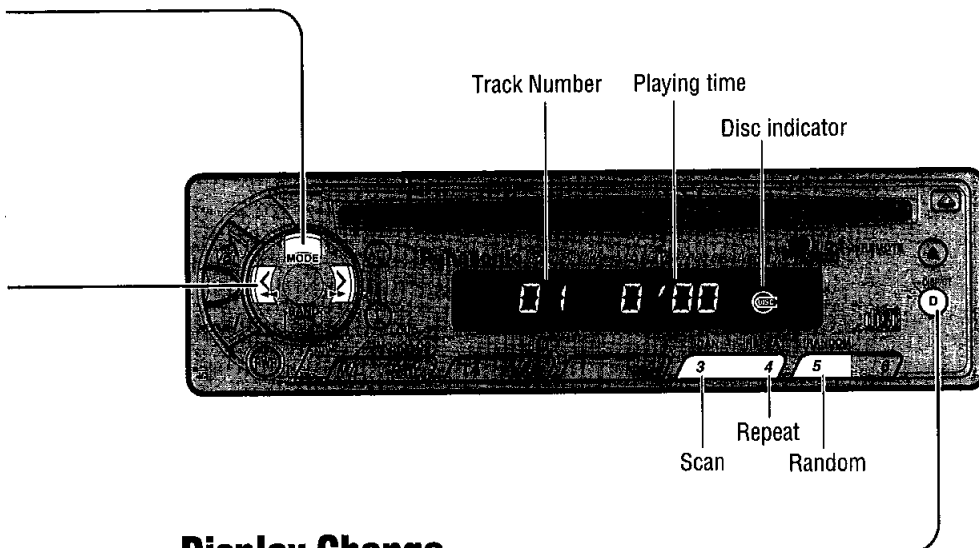







Display Change

Press **[D]** (DISP/CT) to switch to the clock display.
Press again to cancel.



Error Display Messages for CD Player

<ul style="list-style-type: none"> • Press [5] (RANDOM). All tracks are played in random order. • Press again to cancel. 	
<ul style="list-style-type: none"> • Press [3] (SCAN). The first 10 seconds of each track on the disc are played in sequence. • Press again to cancel. 	
<ul style="list-style-type: none"> • Press [4] (REPEAT). The current track is repeated. • Press again to cancel. 	

	<p>CD is dirty or inverted. The disc will be ejected automatically.</p>
	<p>CD is scratched. The disc will be ejected automatically.</p>
	<p>CD stops operating for some reason. Please eject the CD. If the error message E3 is still displayed, please turn off the car engine (ACC off) and remove the fuse from the battery lead (yellow) for 1 minute or more. Then reinstall the fuse.</p>

Installation

Preparation

- Before installation, check the radio operation with antenna and speakers.
- Disconnect the cable from the negative (-) battery terminal (see caution below).
- Unit should be installed in a horizontal position with the front end up at a convenient angle, but not more than 30°.

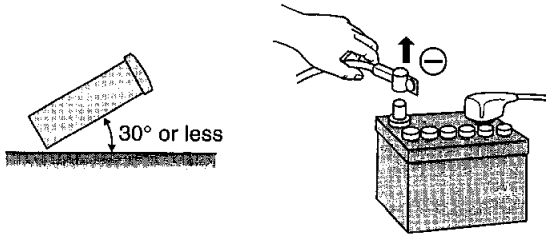

Caution - Do not disconnect the battery terminals of a car with trip or navigational computer since all user settings stored in memory will be lost. Instead take extra care with installing the unit to prevent shorts.

Dashboard Installation

Installation Opening

The unit can be installed in any dashboard having an opening as shown at right. The dashboard should be 4.5 mm - 6 mm thick in order to be able to support the unit.

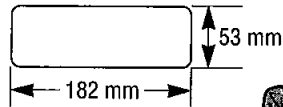

Installation Precautions

This product should be installed by a professional installer, if possible.

In case of difficulty, please consult your nearest authorized Panasonic Service Center.

1. This system is to be used only in a 12-volt, DC battery system (car) with negative ground.
2. Follow the electrical connections carefully (➔ Page 20). Failure to do so may result in damage to the unit.
3. Connect the power lead after all other connections are made.
4. Be sure to connect the battery lead (yellow) to the positive terminal (+) of the battery or fuse block (BAT) terminal.
5. Insulate all exposed wires to prevent short circuiting.
6. Secure all loose wires after installing the unit.
7. Please carefully read the operating and installation instructions of the respective equipment before connecting it to this unit.





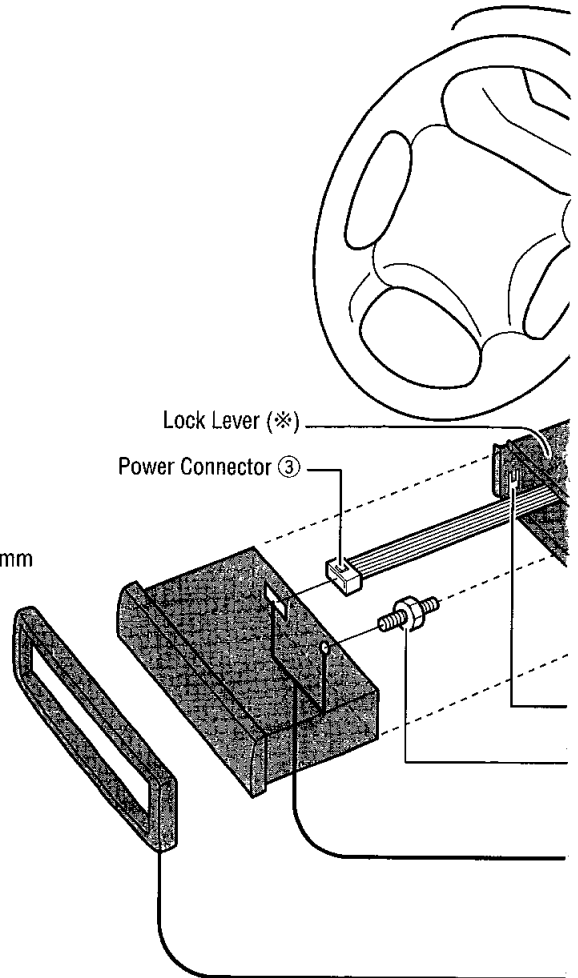

• We strongly recommend that you wear gloves for installation work to protect yourself from injuries.

First complete the electrical connections, and then check them for correctness. (➔ Page 20).



When bending the mounting tab of the mounting collar with a screwdriver, be careful not to injure your hands and fingers.

Supplied Hardware

No.	Item	Diagram	Q'ty
①	Mounting Collar		1
②	Mounting Bolt (5 mmø)		1
③	Power Connector		1
④	Removable Face Plate Case		1
⑤	Trim Plate		1
⑥	ISO Antenna Adaptor		1

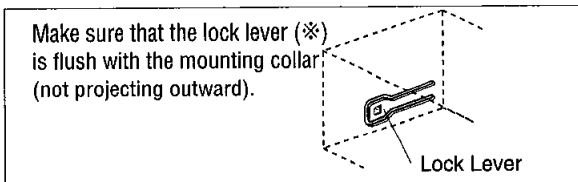
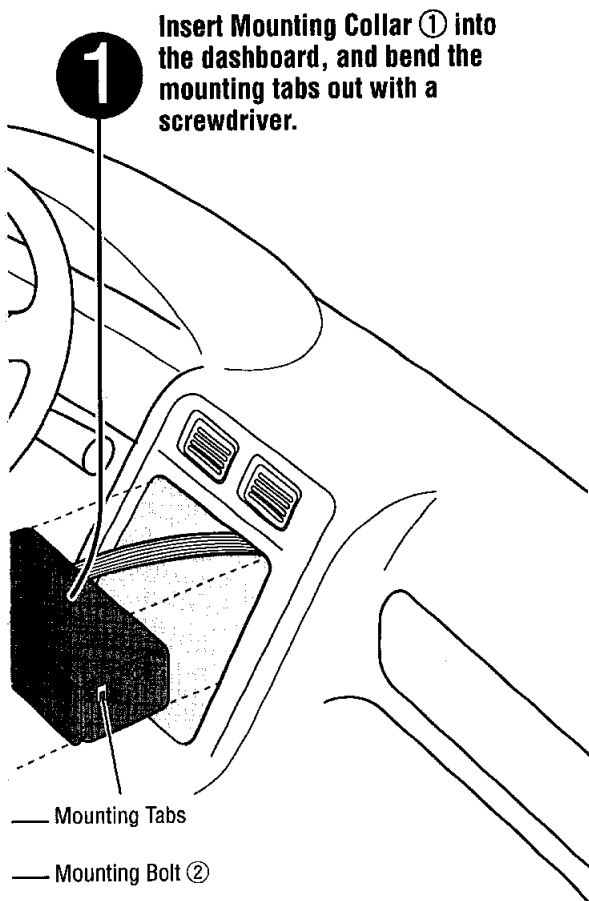

(a) Using the Rear Support Strap (Option)

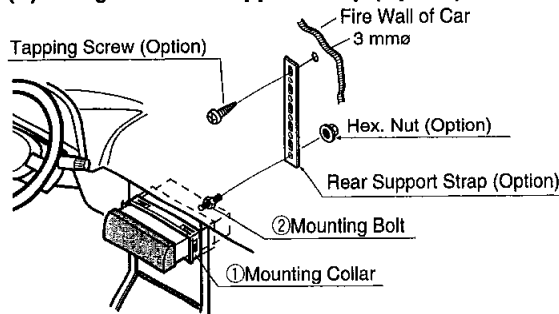

(b) Using the Rubber Cushion (Option)

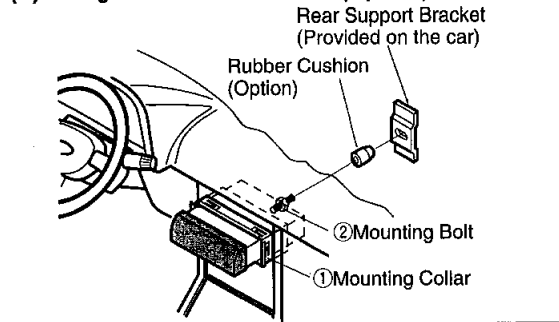

2 Secure the rear of the unit. After fixing Mounting Bolt ② and Power Connector ③, fix the rear of the unit to the car body by either method (a) or (b) shown at right.

3 Insert Trim Plate ⑤.

4 After installation reconnect the negative (-) battery terminal.

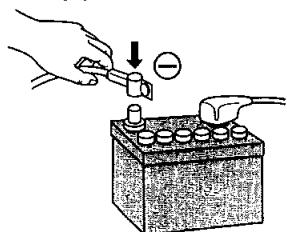

Installation (continued)

To Remove the Unit

1 Remove the removable face plate.

(a) Press the release button [↑].

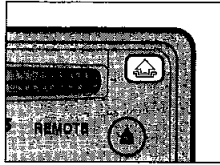

(b) Pull on the right side of the unit.

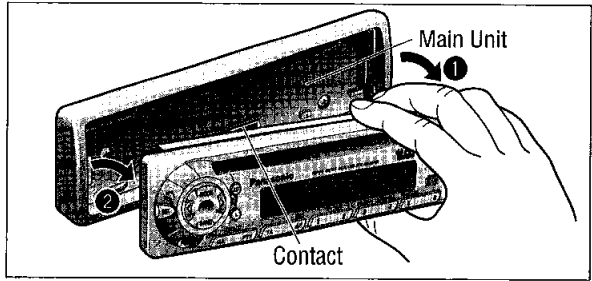

2 Remove the trim plate ⑤ with a screwdriver.

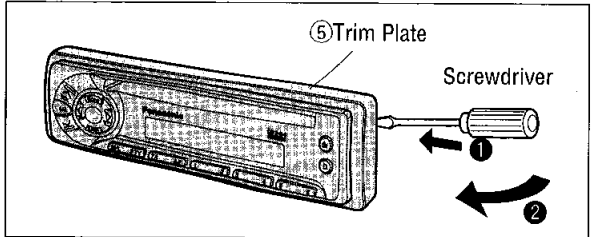

3 Pull out the unit while pushing down the lock lever with a screwdriver.

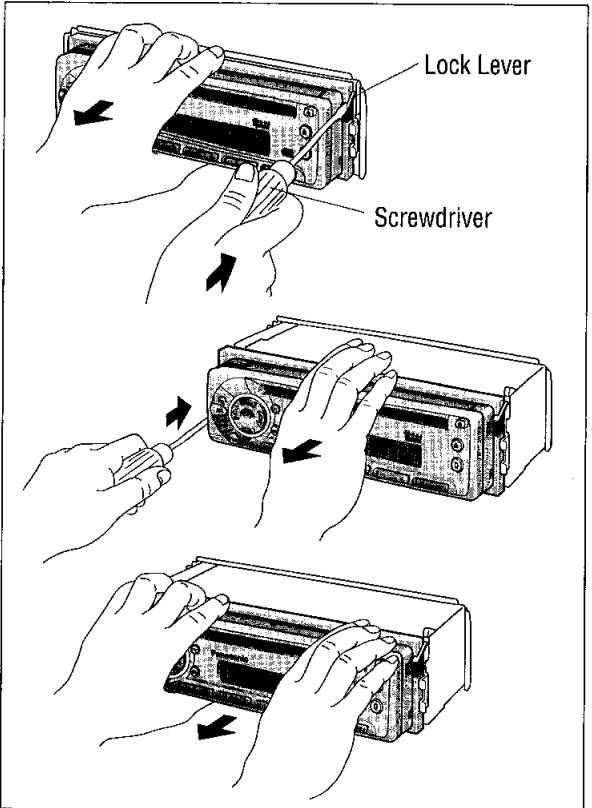

4 Remove the unit pulling with both hands.

Cautions:

- Do not touch the contacts on the face plate or on the main unit, since this may result in poor electrical contacts.
- If dirt or other foreign substances get on the contacts, wipe them off with clean and dry cloth.

Anti-Theft System

This unit is equipped with a removable face plate. Removing this face plate makes the radio totally inoperable. The security indicator will blink.

Place Removable Face Plate into Case

- ① Switch off the power of the unit.
- ② Remove the removable face plate. (→ Page 18.)
- ③ Gently press the bottom of the case and open the cover. Place the face plate into the case and take it with you when you leave the car.

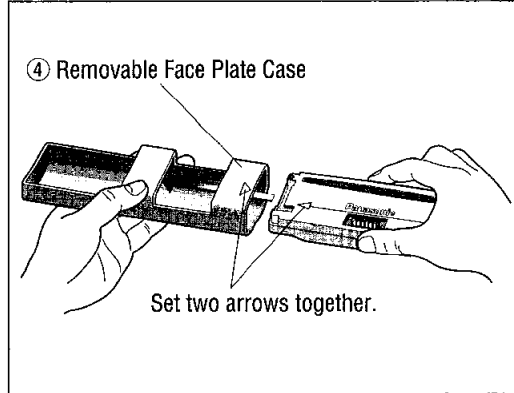

Cautions:

- This face plate is not water-proof. Do not expose it to water or excessive moisture.
- Do not remove the face plate while driving your car.
- Do not place the face plate on the dashboard or nearby areas where the temperature rises to high levels.

Install Removable Face Plate

- ① Slide the left side of the removable face plate in place.
- ② Press the right end of removable face plate until "click" is heard.

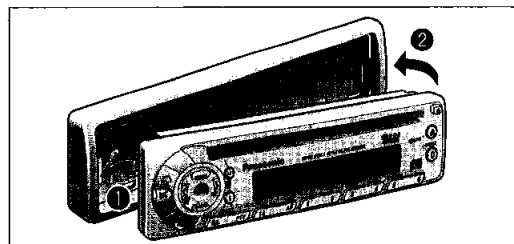

Security Indicator

The security indicator blinks when the removable face plate is removed from the unit.

- Press and hold [SEL]. "LED ON" is displayed. The security indicator turns on.
- Press and hold [SEL] again to cancel.

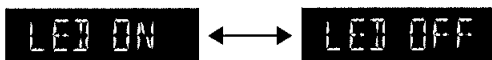

Security Indicator

Display	Security Indicator	Panel Removal Alarm
LED ON	Blinks	ON
LED OFF	OFF	OFF

Panel Removal Alarm

This alarm sounds to warn you not to forget to remove the panel before leaving your car. This function is activated when the security indicator is on.

Electrical Connections

Cable Wiring Diagram

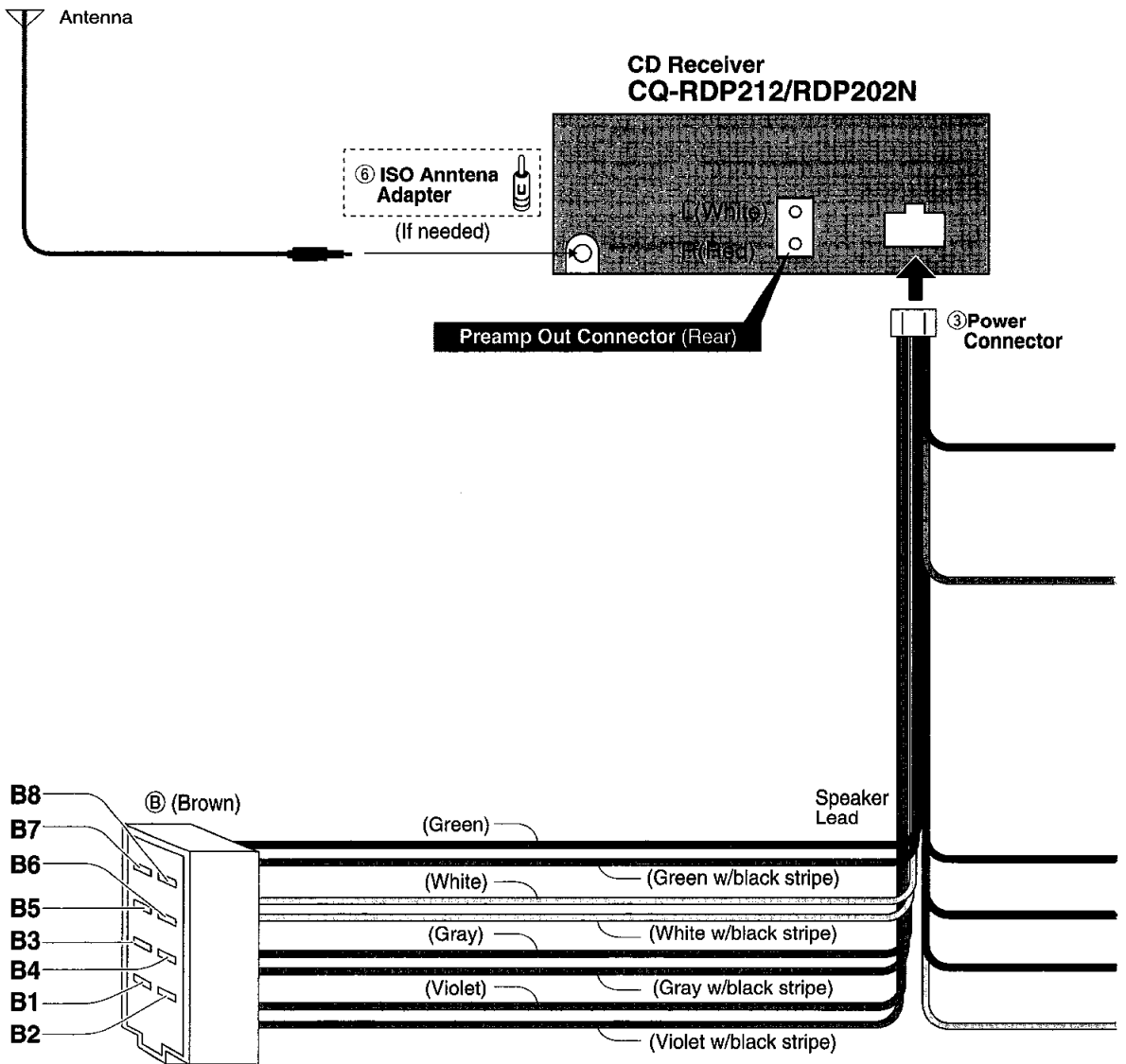

Loudspeakers (connector B : B1-B8)

	Left +	Left -	Right +	Right -
Front	B5 (White)	B6 (White w/black stripe)	B3 (Gray)	B4 (Gray w/black stripe)
Rear	B7 (Green)	B8 (Green w/black stripe)	B1 (Violet)	B2 (Violet w/black stripe)

Cautions:

- Check the connectors provided on your car (see note on page 4 and 5) before connecting the system.
- This unit is designed for use in a car having a 12-volt negative ground battery system.
- To prevent damage to the unit, be sure to follow the connection diagram below.
- Strip about 5 mm of the lead ends for connection (only non-ISO connector cords).
- Do not insert the power connector into the unit until the wiring is completed.
- Be sure to insulate any exposed wires to prevent short circuiting with the car chassis. Bundle all cables, and prevent cable terminals from touching any metal parts.

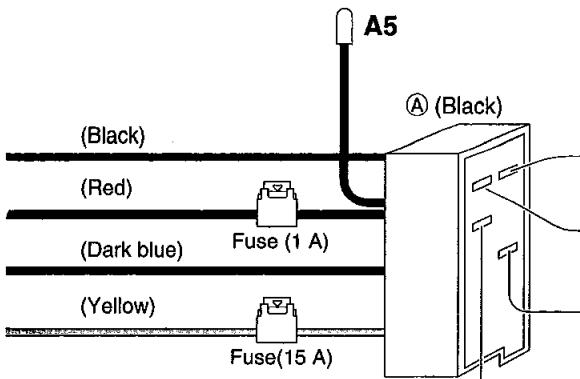
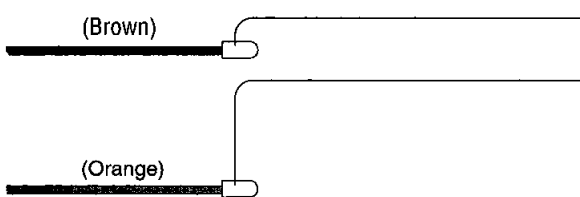

C1 : (Brown)
Not used

C2 : (Orange)
Telephone Mute Lead (*)
Connect to the car telephone mute lead.
Note: The telephone mute lead is only for connection to the radio mute lead. Output other than telephone will not be muted

Navi Mute Lead ()**
To the Navi Mute lead of the Panasonic car navigation system.

* Telephone Mute
The sound from the speakers cannot be heard while the telephone conversation is in progress.

**Navi Mute
The sound from the speakers cannot be heard while the navigation guide is on.

A8 : Ground Lead (Black)
To a clean, bare metallic part of the car chassis

A7 : Power Lead (ACC or IGN) (Red)
To ACC power, +12VDC

A5 : (Dark blue)
Motor Antenna Relay Control Lead
(To Motor Antenna) (Max. 500mA)
This lead is not intended for use with a switch actuated power antenna.

Amp-Relay Control Power Lead
This lead is for connection to a Panasonic power amplifier.

A4 : Battery Lead (Yellow)
To the car battery, continuous + 12V DC

Speaker Connections

Caution: Please follow the instructions given below. Failure to do so will cause damage to the unit and speakers.

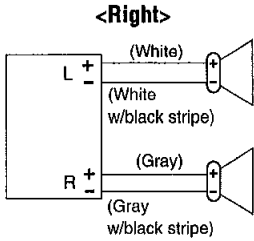

- Use ungrounded speaker only.
- The maximum speaker output should be 40 W or more. (If used with the optional power amplifier, the speaker output should be higher than the maximum amplifier output.)
- The speaker impedance should be 4 – 8 Ω.
- This unit uses the BTCL circuit, so each speaker should be connected separately using parallel vinyl insulated cords.
- The speaker cords and the power amplifier unit should be kept away (about 30 cm apart) from the antenna and antenna extension cord.

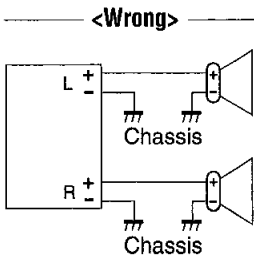

- Never connect the speaker cord to the body of the car.

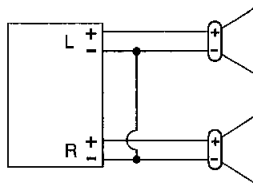

- Do not use a 3-wire type speaker system having a common earth lead.

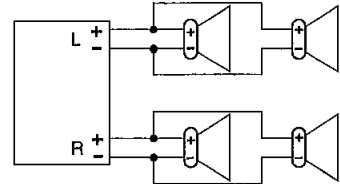

- Do not connect more than one speaker to one set of speaker leads.

Fuse

Use fuses of the same specified rating (15 A). Using different substitutes or fuses with higher ratings, or connecting the unit directly without a fuse, could cause fire or damage to the unit. If the replacement fuse fails, contact your nearest authorized Panasonic Service Center.

Maintenance

Your product is designed and manufactured to ensure the minimum of maintenance. Use a soft cloth for routine exterior cleaning. Never use benzine, thinner, or other solvents.

Specifications

General		FM Stereo Radio	
Power Supply	: DC 12 V (11 V - 16 V), Test Voltage 14.4 V, Negative Ground	Frequency Range	: 87.5 - 108 MHz
Tone Controls	: Bass; ±12 dB at 100 Hz Treble; ±12 dB at 10 kHz	Usable Sensitivity	: 6 dB/μV(S/N 30 dB)
Current Consumption	: Less than 2.5 A (CD mode, 0.5 W 4-Speaker)	Stereo Separation	: 35 dB (at 1 kHz)
Maximum Power Output	: 40 W x 4 (at 4 Ω)	MW Radio	
Power Output	: 20 W x 4 (DIN45 324, at 4 Ω)	Frequency Range	: 531 - 1,602 kHz
Speaker Impedance	: 4 - 8 Ω	Usable Sensitivity	: 28 dB/μV (S/N 20 dB)
Pre-Amp Output Voltage	: 2 V (CD mode)	LW Radio	
Pre-Amp Output Impedance	: 600 Ω	Frequency Range	: 153 - 279 kHz
Dimensions (Main Unit)	: 178(W) x 50(H) x 150(D) mm	Usable Sensitivity	: 32 dB/μV (S/N 20 dB)
Weight (Main Unit)	: 1.5 kg	CD Player	
		Sampling Frequency	: 8 times oversampling
		DA Converter	: 1 bit DAC System
		Error Correction System	: Panasonic Super Decoding Algorithm
		Pick-Up Type	: 3-beam
		Light Source	: Semiconductor laser
		Wavelength	: 780 nm
		Frequency Responce	: 20 Hz - 20 kHz (±1 dB)
		Signal to Noise Ratio	: 96 dB
		Total Harmonic Distortion	: 0.01 % (1 kHz)
		Wow and Flutter	: Below measurable limits
		Channel Separation	: 75 dB

Note: Specifications and design are subject to modification without notice due to improvements.