



# Panasonic®

## Operating Instructions Plasma Television

Model No. **TH-58PZ800B**  
**TH-65PZ800B**

# VIERA

VIERA  
Link



DVB®

AVCHD™

GUIDEplus™  
GEMSTAR



DOLBY  
DIGITAL

SRS  
TruSurround XT

SD  
HG

FULL  
HD  
1920x1080p

HD  
ready  
1080p

HDMI™  
HIGH-DEFINITION MULTIMEDIA INTERFACE

Please read these instructions before operating your set and retain them for future reference.  
The images shown in this manual are for illustrative purposes only.

**U.K. Standard**

English



TQB0E0613

# Turn your living room into a home theatre!

Experience an amazing level of multi-media excitement

## ■ Receives digital terrestrial broadcasts using an integrated DVB (Digital Video Broadcasting) tuner

Display DVB programmes with TV Guide (p. 20) / Timer Programming (p. 40) / Register and instantly call up favourite programmes with Profile Edit (p. 32)

## ■ Sharp pictures with HDMI connection

Enjoy high-definition digital picture and high-quality sound by using an HDMI cable (p. 52)

● This TV incorporates HDMI™ (Version 1.3 with Deep Colour, x.v.Color™) technology.

## ■ Links up and controls the connected equipment with “Q-Link” and “VIERA Link”

Easy recording and playback, create home theatre without complicated settings, etc. (p. 44)

## ■ Supports Audio Description signal (p. 15 and p. 26)

This function can add an additional audio track to describe events on-screen and aids understanding and enjoyment, particularly for visually-impaired viewers.

## ■ Provides high quality surround sound

SRS TruSurround XT creates a high quality surround sound effect. (p. 26)

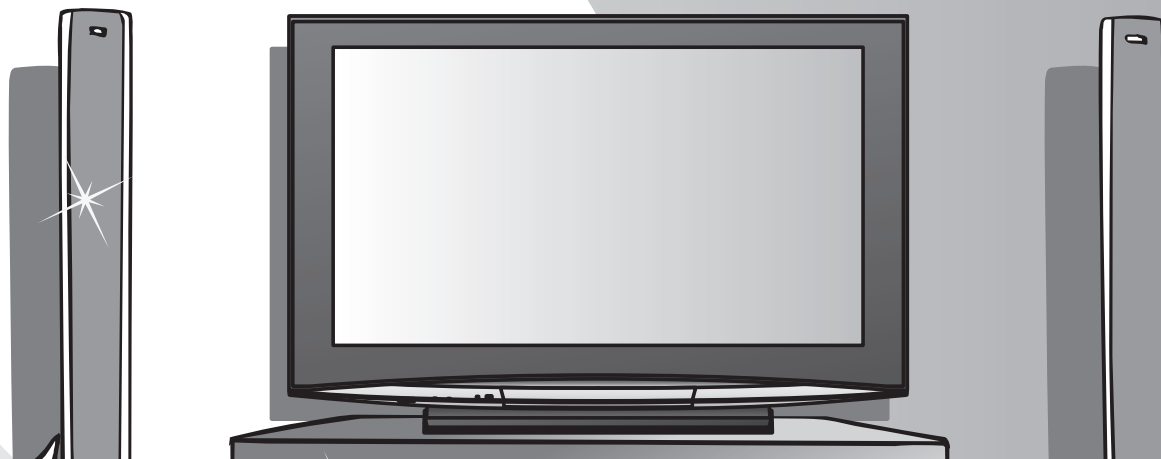

## Digital Switchover

Starting in late 2007 and ending in 2012, TV services in the UK will go completely digital, TV region by TV region.

If you have any questions, please call Digital UK on **08456 50 50 50** or visit **[www.digitaluk.co.uk](http://www.digitaluk.co.uk)**

Digital Switchover will cover a period of several weeks. When it starts you will lose all Analogue TV programmes and some Digital TV programmes will be missing. You will need to retune your TV each time this happens to recover your digital programmes.

● To retune your TV → “Auto Setup” in “Tuning Menu” (p. 35)

Cable or Satellite users should still retune the TV to continue to receive Freeview services via their aerial. (Your Analogue programme for viewing Cable or Satellite services will change to a new position.)

● Due to the digital reception technologies involved, quality of the digital signals may be relatively low in some cases, despite good reception of analogue programmes.



Trade Mark of the DVB Digital Video Broadcasting Project (1991 to 1996)  
TH-58PZ800B Declaration of Conformity No. 5266, 9 January 2008  
TH-65PZ800B Declaration of Conformity No. 5267, 9 January 2008

# Contents

## Be Sure to Read

- Safety Precautions (Warning / Caution) ..... 4
- Notes ..... 5
- Maintenance ..... 5

## Quick Start Guide

- Accessories / Options ..... 6
- Identifying Controls ..... 9
- Basic Connection ..... 10
- Auto Setup ..... 12

## Enjoy your TV!

### Basic Features

- Watching TV ..... 14
- Viewing Teletext ..... 17
- Using TV Guide ..... 20
- Watching VCR, DVD and Satellites ..... 22
- How to Use Menu Functions (picture, sound quality, etc.) ..... 24

### Advanced Features

- DVB Settings (DVB) (pay-TV, software update) ..... 30
- Editing Programmes ..... 32
- Tuning Programmes ..... 34
- Shipping Condition ..... 36
- Owner ID ..... 37
- Input Labels ..... 38
- Displaying PC Screen on TV ..... 39
- Recording Controls ..... 40
- Viewing from SD Card (Photos and Movies) ..... 42
- Link Functions (Q-Link / VIERA Link) ..... 44
- External Equipment ..... 50

### FAQs, etc.

- Technical Information ..... 52
- FAQs ..... 55
- On screen messages ..... 57
- Glossary ..... 58
- Index ..... 58
- Licence ..... 59
- Specifications ..... 59



### FULL HD

This TV uses a high definition panel to produce high definition pictures close to their original resolution.



### Intelligent Frame Creation

This increases the frame count and allows natural frame-to-frame transitions, for flicker-less motion images with high resolution.



### 100Hz Double Scan

100Hz Double Scan is a function of this TV that reduces large area flicker.

### 30,000:1 Native Contrast (1,000,000:1 Dynamic Contrast)



A wide contrast ratio will deliver pictures with a deep black level and a brighter white level for greater image depth.



### Digital Cinema Colour\*

VIERA's wide colour gamut covers 120 % of the conventional HDTV colour standard. The result is a level of colour expression that approaches Digital Cinema.

\*VIERA emulates the colour of digital cinema projectors currently in theatres.

### x.v.Colour

## x.v.Colour

"x.v.Colour" is a promotion name given to the products that have the capability to realize a wide colour space based on the xvYCC specifications. "x.v.Colour" is a trademark.



### 0.001 msec Panel Response Time

Extremely fast response time to minimise picture lag.



### 24p Real Cinema

The 24p source data of movies is converted into a video signal with 6 frames/0.1 second. This produces smoother movie playback.



### V-AUDIO Surround

Utilises Panasonic's advanced Digital Amplification technology and SRS TruSurround XT.

### Lead-free display



All VIERA plasma display panels are lead-free. This reduces the impact on the environment when recycling or disposing of them in the future.



### Up to 100,000 hours Plasma Panel Lifetime

The Plasma display panel used in the 2008 VIERA TV range is rated for up to 100,000 hours.\*

\*This measurement is based on the time taken for the brightness of the panel to reduce to half of its maximum level. The time taken to reach this level may vary depending on the image content and the environment where the TV is used. Image retention and malfunctions are not taken into account.

# Safety Precautions

## Warning & Caution

### Handling the mains plug and lead

- Ensure that the mains plug is easily accessible at all times. The On / Off switch on this model does not fully disconnect the TV from the mains supply. Remove the mains plug from the wall socket when the TV is not used for a prolonged period of time.
- Ensure the earth pin on the mains plug is securely connected to prevent electrical shock.
  - An apparatus with CLASS I construction shall be connected to a mains socket outlet with a protective earthing connection.
- Do not use any mains lead other than that provided with this TV. (This may cause fire or electrical shock.)

### Do not expose to direct sunlight and other sources of heat

- Avoid exposing the TV to direct sunlight and other sources of heat. To prevent fire never place any type of candle or naked flame on top or near the TV.

### Do not place the TV on sloped or unstable surfaces

- The TV may fall off or tip over.



### Transport only in upright position

- Transporting the TV with its display panel facing upright or downward may cause damage to the internal circuitry.

### IMPORTANT: THE MOULDED MAINS PLUG

FOR YOUR SAFETY, PLEASE READ THE FOLLOWING TEXT CAREFULLY.

This TV is supplied with a moulded three pin mains plug for your safety and convenience. A 10 amp fuse is fitted in this mains plug. Shall the fuse need to be replaced, please ensure that the replacement fuse has a rating of 10 amps and that it is approved by ASTA or BSI to BS1362.

Check for the ASTA mark  or the BSI mark  on the body of the fuse.

If the mains plug contains a removable fuse cover, you must ensure that it is refitted when the fuse is replaced.

If you lose the fuse cover the mains plug must not be used until a replacement cover is obtained.

A replacement fuse cover may be purchased from your local Panasonic dealer.

Do not cut off the mains plug.

Do not use any other type of mains lead except the one supplied with this TV.

The supplied mains lead and moulded plug are designed to be used with this TV to avoid interference and for your safety.

If the socket outlet in your home is not suitable, get it changed by a qualified electrician.

If the plug or mains lead becomes damaged, purchase a replacement from an authorized dealer.

**WARNING: – THIS TV MUST BE EARTHED.**

How to replace the fuse.

Open the fuse compartment with a screwdriver and replace the fuse.

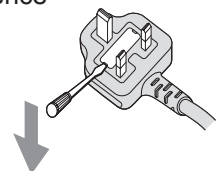

### Power source

- This TV is designed to operate on 220-240 V, 50 / 60 Hz AC.

### Do not remove the cover

- Do not remove the rear cover as live parts are accessible when it is removed. There are no user serviceable parts inside.

### Do not expose your ears to excessive volume from the headphones

- Irreversible damage can be caused.

AC 220-240 V  
50 / 60 Hz

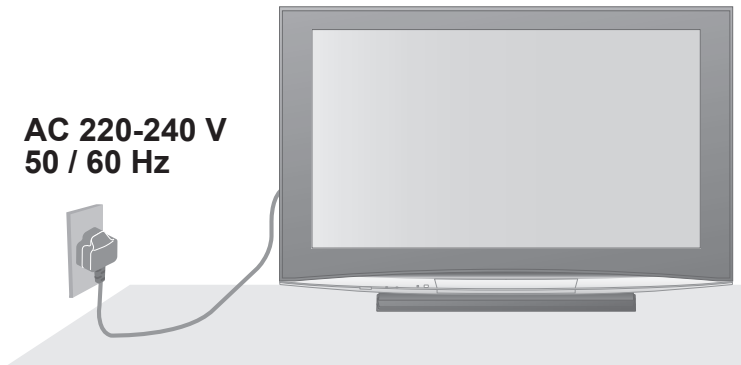

# Notes

## Do not expose to rain or excessive moisture

- To prevent damage which might result in electric shock or fire, do not expose this TV to rain or excessive moisture. This TV must not be exposed to dripping or splashing water and objects filled with liquid, such as vases, must not be placed on top of or above the TV.

## Do not block the rear ventilation openings

- Ventilation should not be impeded by covering the ventilation openings with items such as newspapers, tablecloths and curtains.

## Allow sufficient space around the TV for radiated heat

Minimum distance

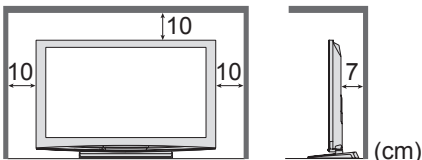

- When using the pedestal, keep the space between the bottom of the TV and the floor surface.
- In case of using Wall-hanging bracket, follow the manual of it.

## Use only the dedicated pedestals / mounting equipment

- Using an unapproved pedestal or other fixtures may make the TV unstable, risking injury. Be sure to ask your local Panasonic dealer to perform setup.
- Use approved pedestals / mounts (p. 6).

## Do not allow children to handle SD Card

- As with a small object, SD Card can be swallowed by young children. Please remove SD Card immediately after use.

## Do not display a still picture for a long time

This causes the image to remain on the plasma screen ("image retention").

This is not considered a malfunction and is not covered by the warranty.

Typical still images

- Programme number and other logos
- Image displayed in 4:3 mode
- Video game
- Computer image



To prevent image retention, contrast is lowered automatically after a few minutes if no signals are sent or no operations are performed. (p. 55)

## Auto power standby function

- If no signal is received and no operation is performed in Analogue TV mode for 30 minutes, the TV will automatically go to standby mode.

## Keep the TV away from these types of equipment

- Electronic equipment  
In particular, do not place video equipment near the TV (electromagnetic interference may distort images / sound).
- Equipment with an infrared sensor  
This TV also emits infrared rays (this may affect operation of other equipment).

# Maintenance

First, remove the mains plug from the socket outlet.

## Display panel

Regular care: Gently wipe the surface clean of dirt by using a soft cloth.  
Major contamination: Wipe the surface clean using a soft cloth dampened with clean water or diluted neutral detergent (1 part detergent to 100 parts water). Then, using a soft dry cloth, evenly wipe the surface clean until it is dry.

### Caution

- The surface of the display panel has been specially treated and may be easily damaged.  
Do not tap or scratch the surface with your fingernail or other hard object.
- Take care not to subject the surface to insect repellent, solvent, thinner, or other volatile substances (this may degrade surface quality).

## Cabinet, Pedestal

Regular care: Wipe the surface clean using a soft dry cloth.  
Major contamination: Dampen a soft cloth with clean water or water containing a small amount of neutral detergent. Then, wring the cloth and wipe the surface clean with it. Finally, wipe the surface clean with a dry cloth.

### Caution

- Take care not to subject the TV's surfaces to detergent. (A liquid inside the TV could lead to product failure.)
- Take care not to subject surfaces to insect repellent, solvent, thinner, or other volatile substances (this may deteriorate the surface by peeling the paint).
- Do not allow the cabinet and pedestal to make contact with a rubber or PVC substance for a long time.

## Mains plug

Wipe the mains plug with a dry cloth at regular intervals. (Moisture and dust may lead to fire or electrical shock.)

# Accessories / Options

## Standard accessories

- Remote Control
  - N2QAYB000238



Check that you have the accessories and items shown

- Batteries for the Remote Control (2)
  - R6 (UM3)



- Clamper (2)
  - TMME289
  - p. 8

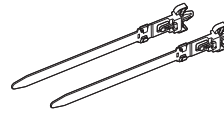

- Mains Lead
  - K2CT3DH00025
  - p. 11

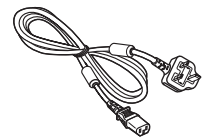

- Operating Instructions
- Pan European Guarantee Card
- 1 Year Guarantee Registration
- CRM (Customer Relationship Management)

- Cleaning cloth
  - TXFPE01RLTB

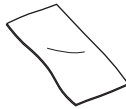

- Pedestal (TH-58PZ800B only)
  - TBLX0082
  - TXFBL01RBTU
  - p. 7

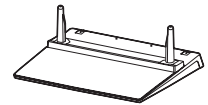

- This product contains possibly dangerous parts (such as plastic bags), that can be breathed in or swallowed by young children accidentally. Keep these parts out of reach of young children.

## Optional accessories

Some items may not be available locally.

### Pedestal

- TY-ST65R4-WL (TH-65PZ800B)

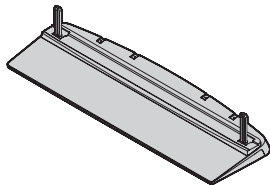

### Wall-hanging bracket (vertical)

- TY-WK42PV4W (TH-58PZ800B)
- TY-WK65PV7 (TH-65PZ800B)

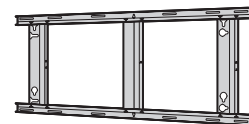
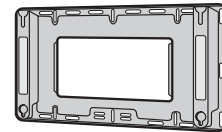

### Caution

- In order to maintain the unit's performance and safety, be absolutely sure to ask your dealer or a licenced contractor to secure the wall-hanging brackets.
- Carefully read the instructions accompanying the pedestal, and be absolutely sure to take steps to prevent the TV from tipping over.
- Handle the TV carefully during installation since subjecting it to impact or other forces may cause product damage.

## Installing / removing remote's batteries

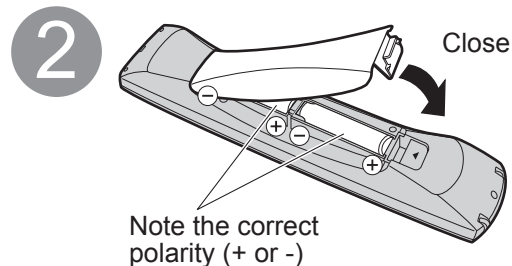
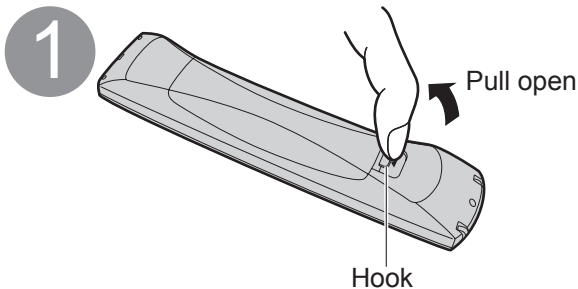

### Caution

- Incorrect installation may cause battery leakage and corrosion, resulting in damage to the remote control.
  - Do not mix old and new batteries.
  - Do not mix different battery types (such as alkaline and manganese batteries).
  - Do not use rechargeable (Ni-Cd) batteries.
  - Do not burn or breakup batteries.
- Batteries must not be exposed to excessive heat such as sunshine, fire or the like.

## Attaching the pedestal (TH-58PZ800B only)

### Warning

**Do not disassemble or modify the pedestal.**

- Otherwise the TV may fall over and become damaged, and personal injury may result.

### Caution

**Do not use any other TV and displays.**

- Otherwise the TV may fall over and become damaged, and personal injury may result.

**Do not use the pedestal if it becomes warped or physically damaged.**

- If you use the pedestal while it is physically damaged, personal injury may result. Contact your nearest Panasonic dealer immediately.

**During set-up, make sure that all screws are securely tightened.**

- If insufficient care is taken to ensure screws are properly tightened during assembly, the pedestal will not be strong enough to support the TV, and it might fall over and become damaged, and personal injury may result.

**Ensure that the TV does not fall over.**

- If the TV is knocked or children climb onto the pedestal with the TV installed, the TV may fall over and personal injury may result.

**Two or more people are required to install and remove the TV.**

- If two or more people are not present, the TV may be dropped, and personal injury may result.

Ⓐ Assembly screw (4)  
(silver)  
● XYN5+F18FN



M5 × 18

Ⓑ Assembly screw (4)  
(black)  
● THEL068N

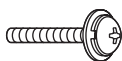

M5 × 35

Ⓒ Pole (2)  
● R: TBLA3632  
● L: TBLA3633

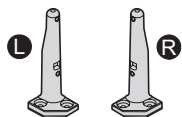

Ⓓ Base  
● TBLX0082

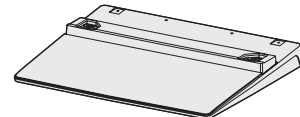

### Assembling the pedestal

Use the four assembly screws (A) to fasten the left and right poles to the base securely.

- Make sure that the screws are securely tightened.
- Forcing the assembly screws the wrong way will strip the threads.
- "L" or "R" mark is stamped on the bottom of the pole.

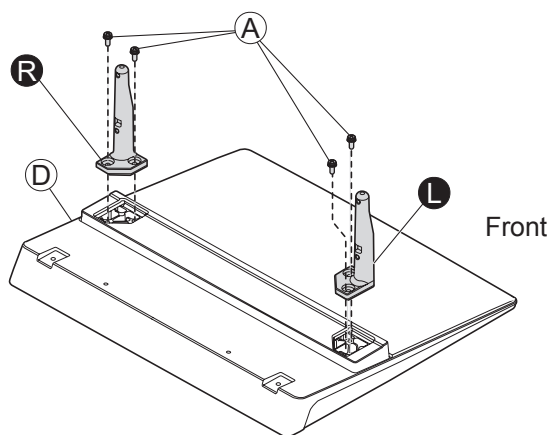

### Securing the TV

Use the assembly screws (B) to fasten securely.

- Make sure that the screws are securely tightened.
- Carry out the work on a horizontal and level surface.

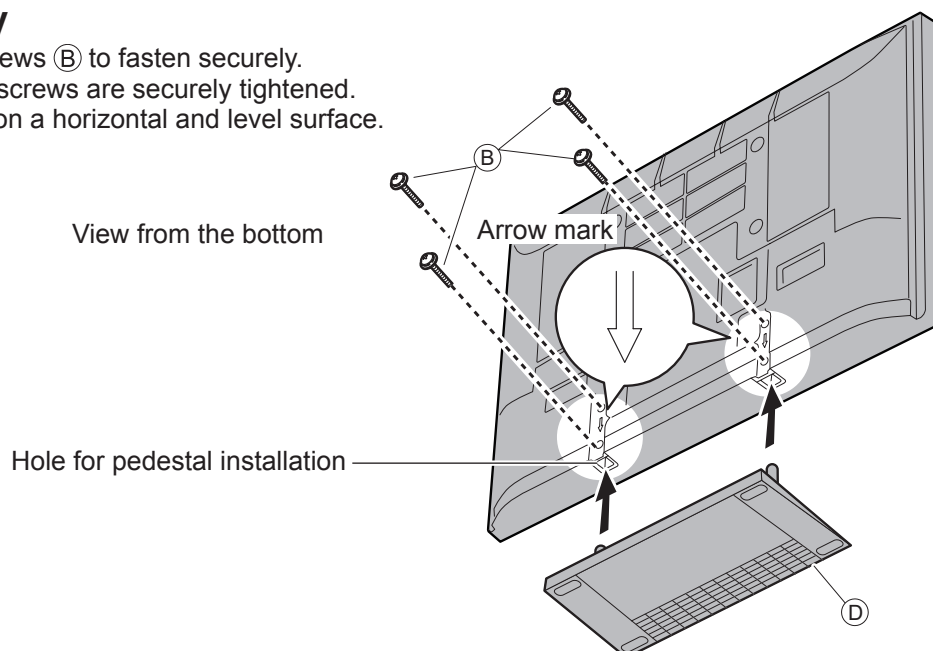

# Accessories / Options

## Using the clammer

Rear of the TV

● TH-58PZ800B

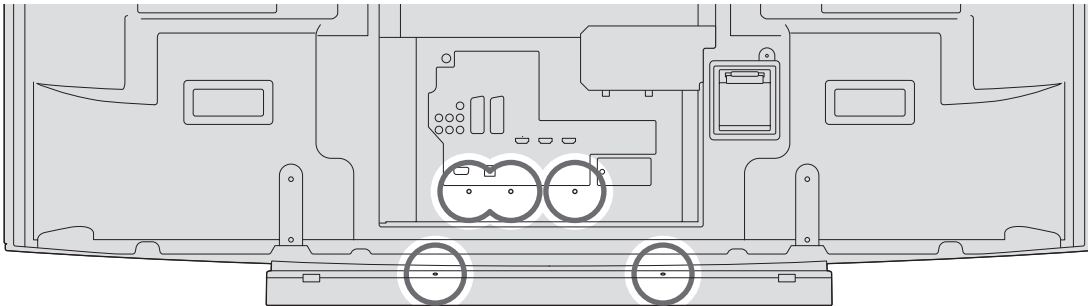

● TH-65PZ800B

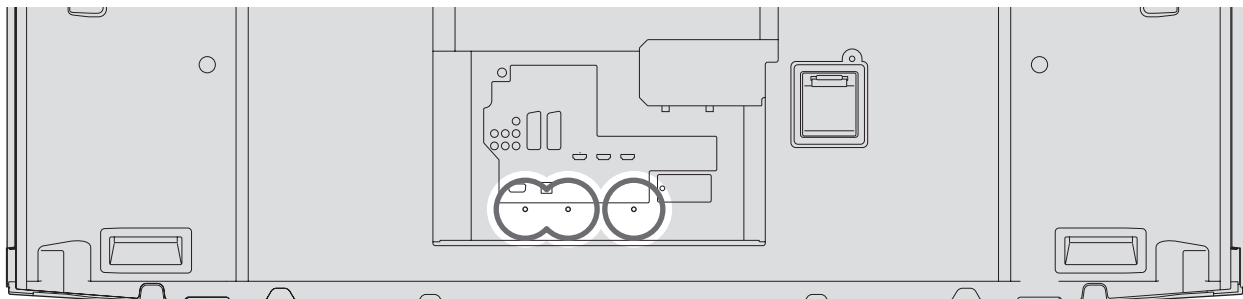

**■ Attach the clammer**

hole

Insert the clammer in a hole

**To remove from the TV:**

snaps

① Keep pushing both side snaps

**■ Bundle the cables**

hooks

② Set the tip in the hooks

**To loosen:**

knob

① Keep pushing the knob

- Do not bundle the RF cable and mains lead together (could cause distorted image).
- Fix cables with clammers as necessary.
- When using the optional accessory, follow the option's assembly manual to fix cables.

# Identifying Controls

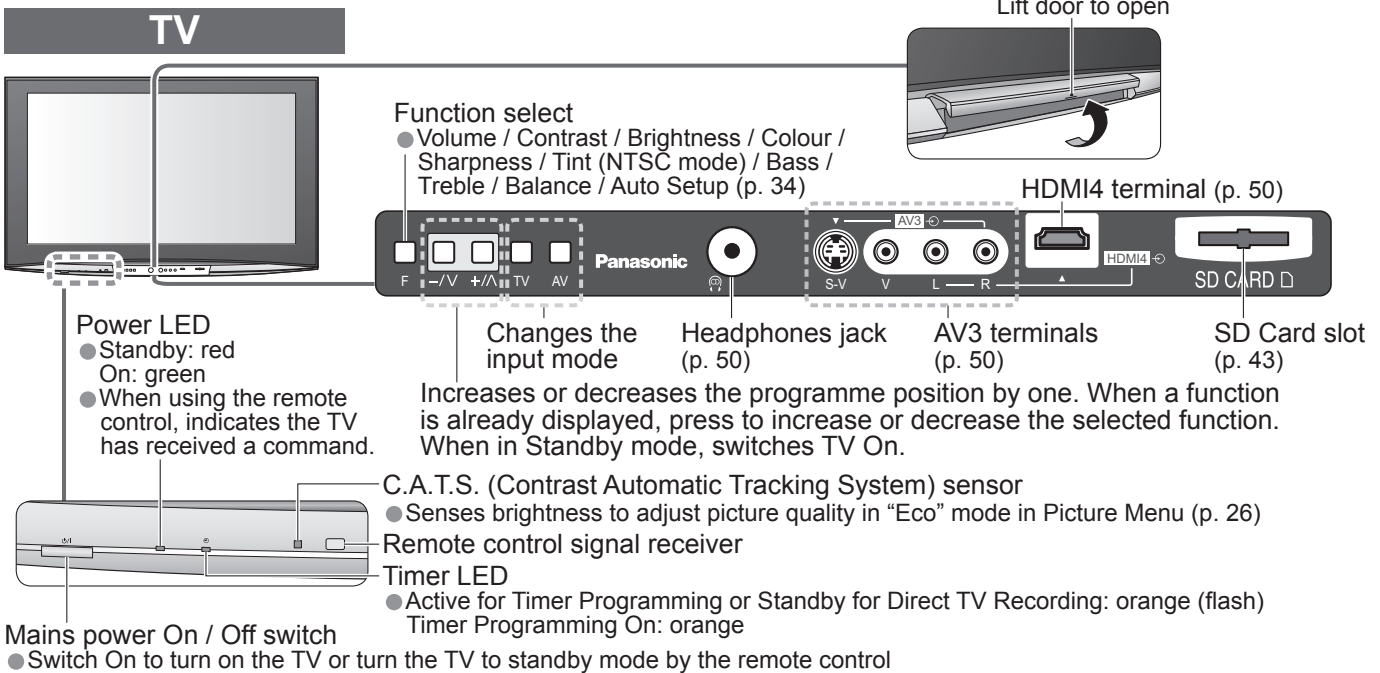

## Remote Control

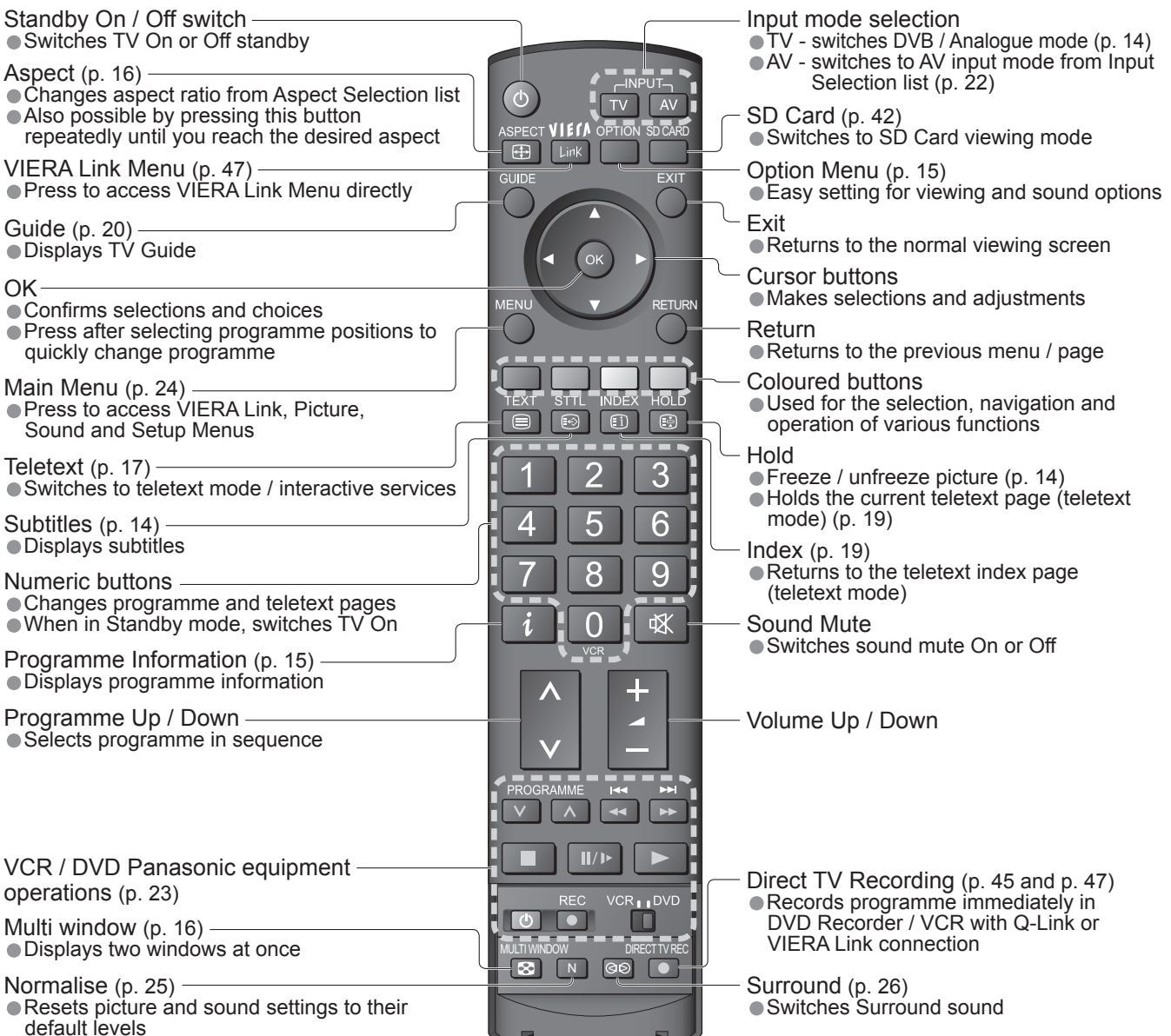

# Basic Connection

External equipment and cables shown are not supplied with this TV.  
Please ensure that the unit is disconnected from the mains socket before attaching or disconnecting any leads.  
When disconnecting the mains lead, be absolutely sure to disconnect the mains plug at the socket outlet first.

## Example 1 Connecting aerial

### TV only

Rear of the TV

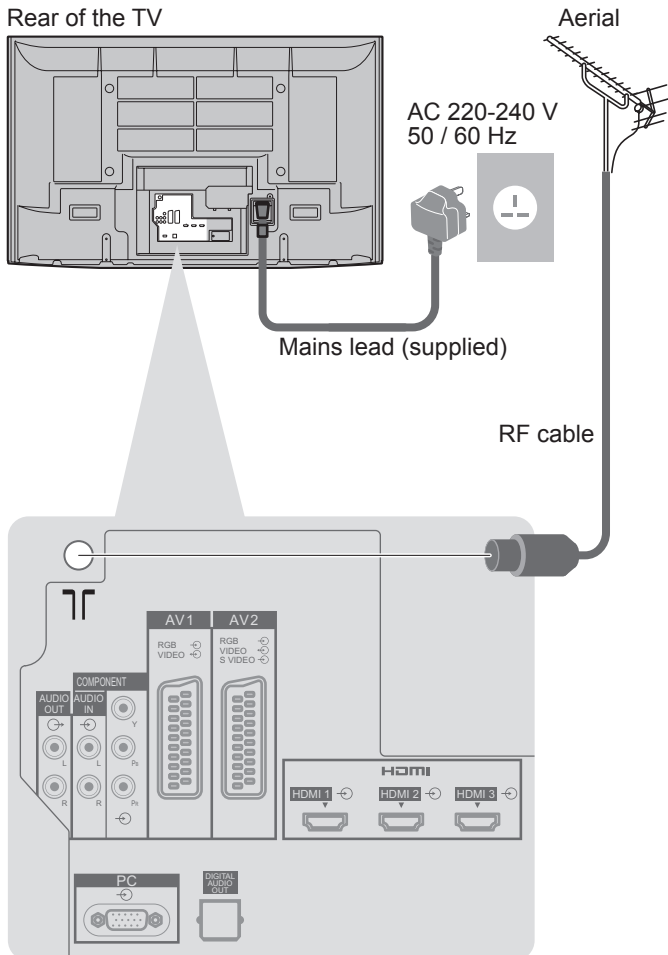

## Example 2 Connecting DVD Recorder / VCR

### TV, DVD Recorder or VCR

Rear of the TV

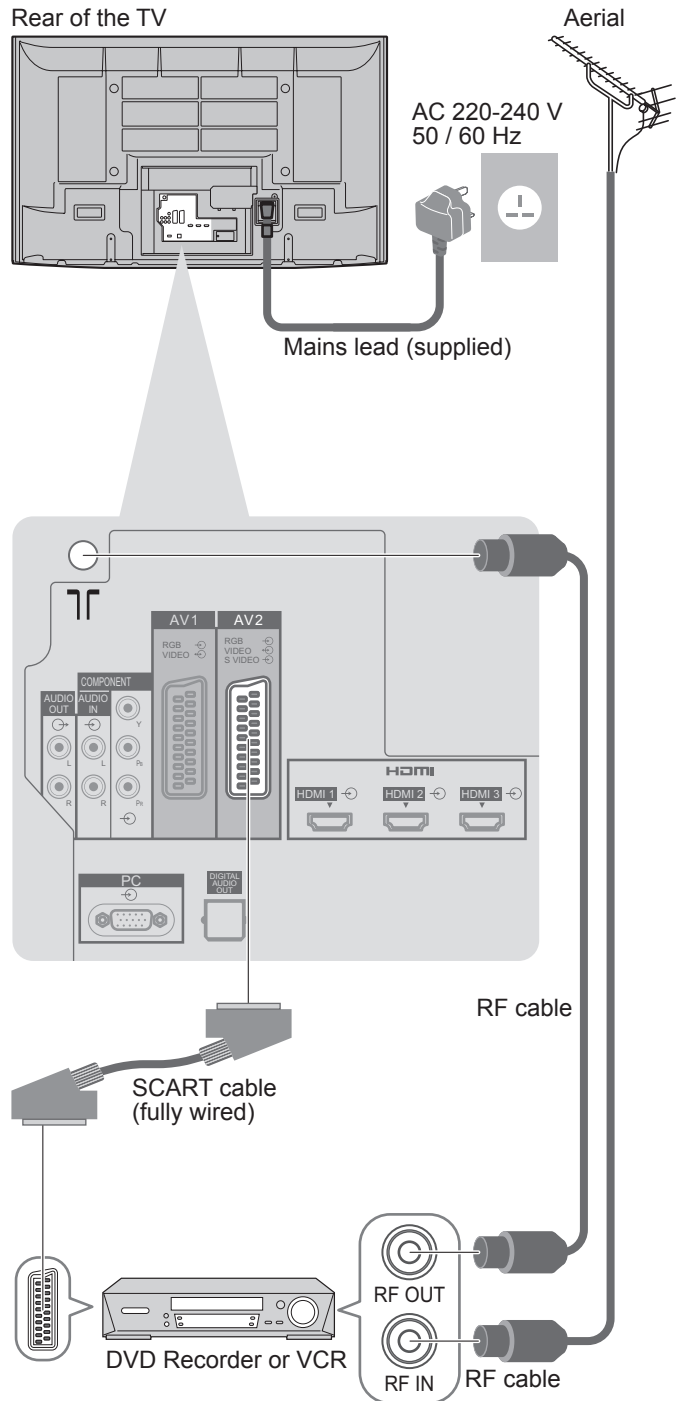

### Note

- Connect to AV2 for a DVD Recorder / VCR supporting Q-Link (p. 45).
- Connect to AV1 for a Satellite receiver.
- For HDMI-compatible equipment, possible to connect to HDMI terminals (HDMI1 / HDMI2 / HDMI3 / HDMI4) by using HDMI cable (p. 50).
- Q-Link connection → p. 44
- VIERA Link connection → p. 44
- Read the manual of the equipment too.

## Example 3 Connecting DVD Recorder / VCR and Satellite receiver

### TV, DVD Recorder / VCR and Satellite

Rear of the TV

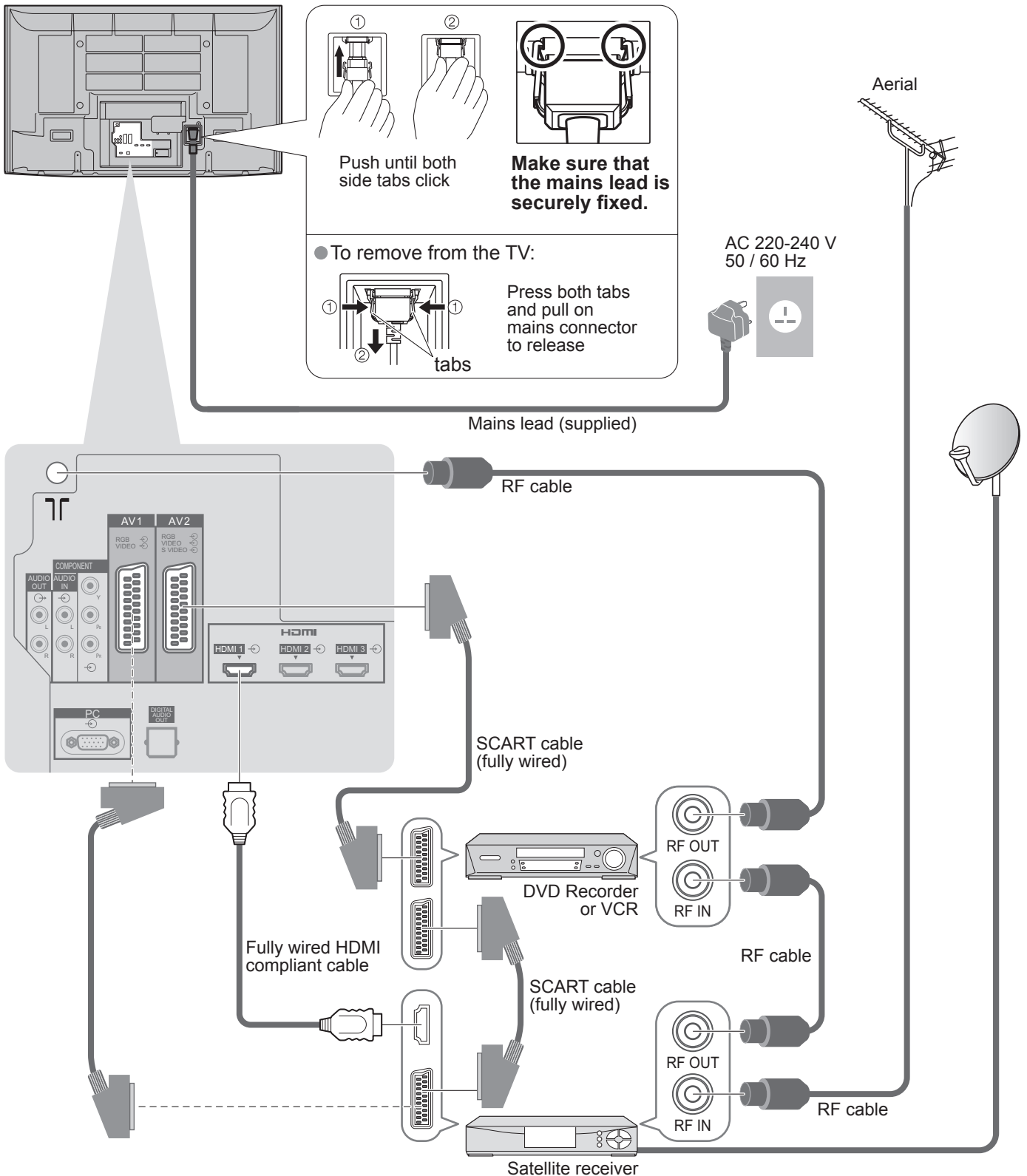

# Auto Setup

Search and store TV programmes automatically.  
These steps are not necessary if the setup has been completed by your local dealer.

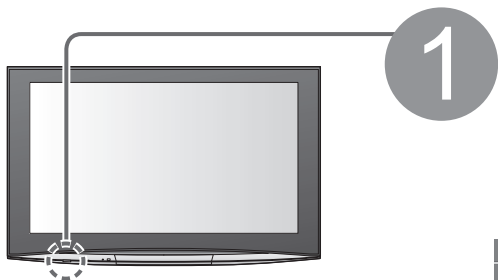

**1 Plug the TV into mains socket and switch On**  
(Takes a few seconds to be displayed)

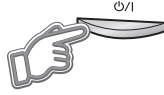

**Auto Setup - Digital and Analogue**

Digital Scan: 21 | 68  
Analogue Scan: 21 | 68

This will take about 8 minutes.

Channel	Service Name	Type	Quality
62	CBBC Channel	Free TV	10
62	BBC Radio Wales	Free TV	10
62	E4	Free TV	10
62	Cartoon Nwk	Free TV	10
29		Analogue	1-
33	BBC1	Analogue	1-

Free TV: 4   Pay TV: 0   Radio: 0   Data: 0   Analogue: 2

EXIT

- Auto Setup will start to search for TV programmes and store them in the numbered order as specified by the broadcasters.

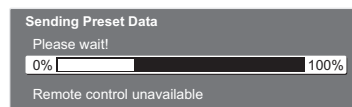
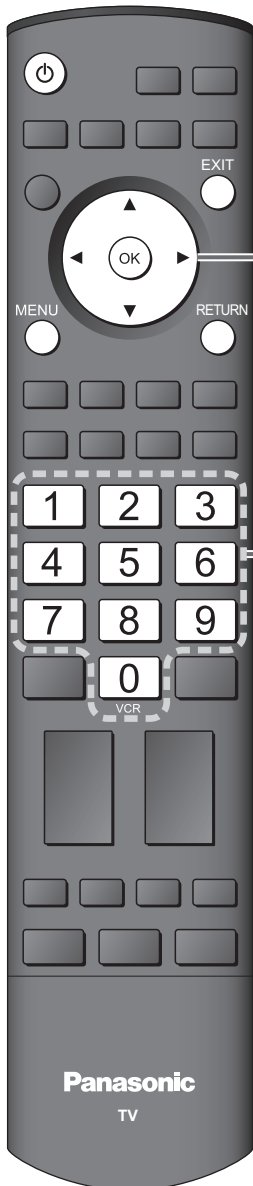

- If Q-Link, or similar technology (p. 45), compatible recorder with analogue tuner is connected, analogue programme information is automatically downloaded to the recorder. (Digital programme information is not downloaded.)

## ■ When inputting Owner ID

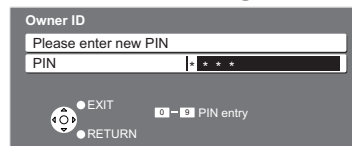

Following the on-screen operation guide, enter your own choice of PIN number, name, etc.

- For detailed procedures → "Owner ID" (p. 37)
- Make a note of the PIN number in case you forget it.

## ■ When inputting Owner ID later



- If you input the ID later → "Owner ID" (p. 37)

## 3 Select the picture setting



- "Home" and "Shop" are equal to "Normal" and "Dynamic" respectively - "Viewing Mode" in "Picture Menu" (p. 26)

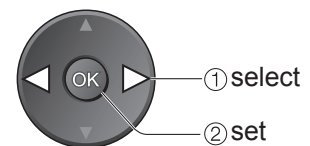

**Auto Setup is now complete and your TV is ready for viewing.**



- To check programme list at-a-glance → "Using TV Guide" (p. 20)
- To edit programmes → "Editing Programmes" (p. 32)

## Using the On Screen Displays

Many features available on this TV can be accessed via the On Screen Display menu.

### ■ How to use remote control

MENU



Open the main menu



Move the cursor / select the menu



Move the cursor / adjust levels / select from a range of options



Access the menu / store settings after adjustments have been made or options have been set

RETURN



Return to the previous menu



Exit the menu system and return to the normal viewing screen

### ■ ON SCREEN HELP Instructions box (example: Owner ID)

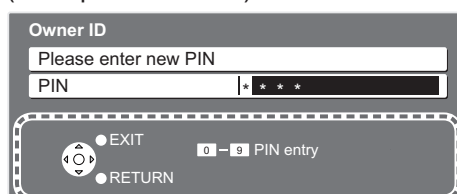

On-screen operation guide will help you.

#### Note

- If tuning has failed → “Auto Setup” (p. 35)
- If downloading has failed → “Q-Link Download” (p. 27)
- To initialize all settings → “Shipping Condition” (p. 36)
- If you turned the TV Off during Standby mode last time, the TV will be in Standby mode when you turn the TV On with Mains power On / Off switch.

# Watching TV

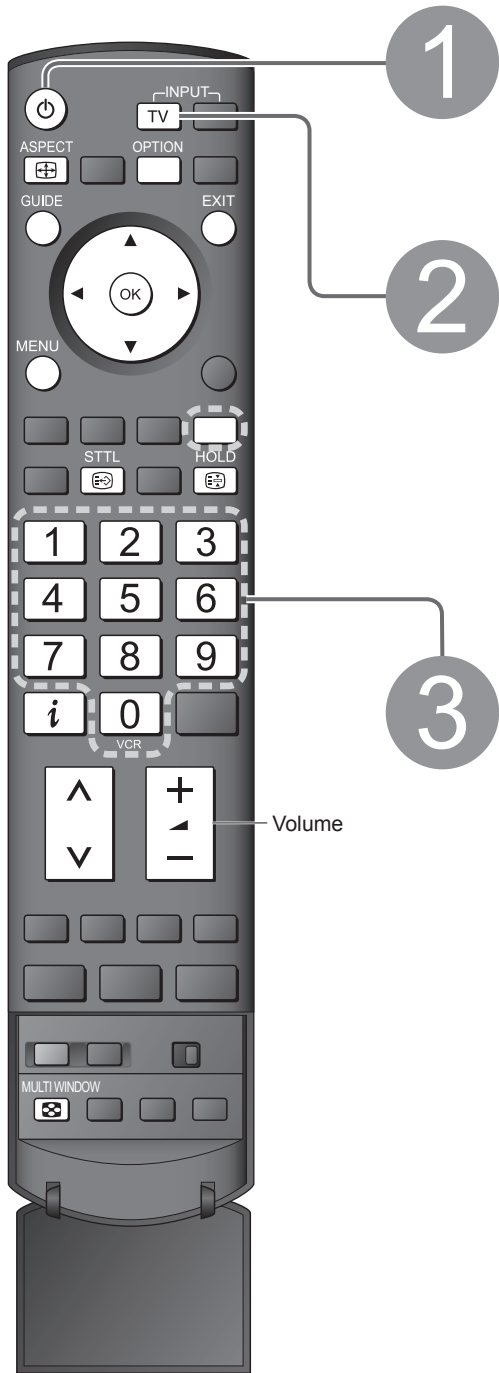

1

**Turn power on**  
(Press for about 1 second)



● Mains power On / Off switch should be On. (p. 9)

2

**Select DVB (Digital Video Broadcasting) or Analogue mode**



● Also possible to select the mode using the TV button on the front panel of the TV. (p. 9)

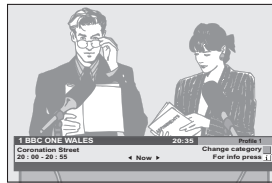

Information banner appears whenever you select a programme

● For details → p. 15

3

**Select a programme**

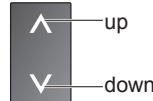

or



DVB programme numbers run from 1 onwards.  
Analogue programme numbers run in the ranges 0 - 99.

● To select a two or three-digit programme number, e.g. 39



Volume

■ **Select a programme using Information banner** (p. 15)  
Possible to confirm the programme name before selecting programmes.

Display Information banner if it is not displayed

While the banner is displayed, select the programme



● Possible to set display timeout in "Banner Display Timeout" (p. 27).

■ **Select a programme using TV Guide** (p. 20)  
Possible to confirm the TV Guide (EPG) before selecting programmes.

Display TV Guide

Select the event now on the air

Select "View"

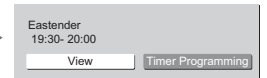
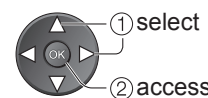

**Note**

● To watch pay-TV → p. 31

■ **Other useful functions**

<b>Hold</b>	<b>Freeze / unfreeze picture</b>	HOLD 
<b>Display subtitles</b>	<b>Display / hide subtitles</b> (if available) ● To change the language for DVB (if available) → "Preferred Subtitles" (p. 27)	STTL 

■ Other useful functions

**Display Information banner**

- Also appears when changing a programme

Event: Example (DVB): 1 BBC ONE WALES  
 Programme type (if it is Radio or Data service): Radio  
 Current time: 20:35  
 Category: All DVB Services

Coronation Street  
 20:00 - 20:55  
 Now

Mute Encrypted AD Subtitles TXT Multi Audio 45

Change category For info press i

Example (Analogue):

3 ITV 20:35 All Analogue Services  
 itv1 CH23  
 Mute TXT NICAM 45

Change category

Channel number

- To confirm another tuned programme name →
- To watch the programme listed in the banner →
- To change the category →
- Information on the next event (DVB mode) →
- Extra information (DVB mode) → (press again to hide the banner)
- To hide →
- To set display timeout → "Banner Display Timeout" (p. 27)

**Mute**  
Sound mute On

**Bad signal**  
Poor TV signal quality

**Encrypted**  
Scrambled programme

**AD**  
Audio Description service available  
 ● This function can aid visually-impaired viewers by adding an additional audio track to describe events on-screen.  
 ● For settings → p. 26

**Subtitles**  
Subtitle service available

**TXT**  
Teletext service available

**Multi Audio**  
Multiple audio available

**Stereo, Mono, NICAM**  
Audio mode

**1 - 90**  
Off Timer remaining time  
 ● For settings → see below

Example:

**Check or change the current programme status instantly**

OPTION

- To change → ② change ① select

- Multi Audio** (DVB mode)  
Allows you to select between alternative language for sound tracks (if available)
- Subtitle Language** (DVB mode)  
Allows you to select the language in which subtitles should appear (if available)
- NICAM** (Analogue mode)  
→ Sound Menu (p. 26)

- Volume Correction**  
Adjusts volume of individual programme or input mode
- Audio Description** (DVB mode)  
Select "On" if the programme has Audio Description service, then you will hear an additional audio track to describe events on-screen

**Note**

- Also possible to change the settings in Menu list (p. 26 and p. 27).

**Turn the TV off automatically after a fixed period**

Display the menu

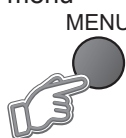

Select "Setup"

VIERA Main Menu  
 VIERA Link  
 Picture  
 Sound  
 Setup

② access  
 ① select

Select "Off Timer" and set the time

Setup Menu 1/3  
 Timer Programming  
 DVB Profile Edit  
 DVB Service List  
 Link Settings  
 Child Lock  
 Tuning Menu  
 GUIDE Plus+ Settings  
 Intelligent Frame Creation On  
 Off Timer Off

② set  
 ① select

- To cancel → Set to "Off" or turn the TV off.
- To display the remaining time → Information banner (above)
- When the remaining time is within 3 minutes, the remaining time will flash on the screen.

Display Information banner

Display the selectable settings for the current programme

Off Timer

# Watching TV

## Other useful functions

### Change aspect ratio

#### Change the aspect ratio

ASPECT



Enjoy viewing the picture at its optimum size and aspect.

Display Aspect Selection list



While the list is displayed, select the mode

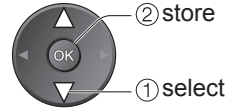

② store

① select



Aspect Selection list

- To change the mode using the ASPECT button only

→ (Press repeatedly until you reach the desired mode)



Auto

The best ratio is chosen and the picture expanded to fill the screen. For details → p. 52



16:9

Directly displays the image at "16:9" without distortion (anamorphic).



14:9

Displays the image at the standard "14:9" without distortion.



4:3

Displays the image at the standard "4:3" without distortion.



Zoom1

Displays a "16:9" letterbox or "4:3" image without distortion.



Zoom2

Displays a "16:9" letterbox (anamorphic) image full-screen without distortion.



Zoom3

Displays a "2.35:1" letterbox (anamorphic) image full-screen without distortion. At "16:9", displays the image at its maximum (with slight enlargement).

#### Note

- Only "16:9" and "4:3" are available in PC mode.
- Not available when Subtitle is active in DVB mode.
- Not available in Analogue teletext mode.
- Aspect mode can be memorized separately for SD (Standard definition) and HD (High definition) signals.

### Watch TV, DVD, etc. in multi window

#### View in multi window

MULTI WINDOW



- Remote control operations apply to the main screen.

Enjoy viewing two images at once, such as a TV programme and a DVD.

#### Picture-in-Picture mode (PinP)

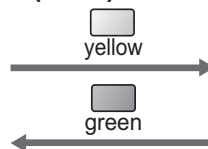

#### Picture-and-Picture mode (PandP)



Main screen Sub screen

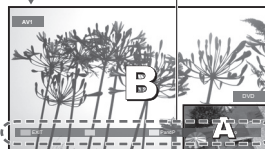

#### Operations in multi window

- To exit multi window (return to the single-screen view with main screen) →
- To change the layout, images, first show the colour bar →

• To change the layout → • To swap → • To exit multi window →

• To change the input mode or programme of sub screen

→ Swap sub screen for main screen → Change the input mode or programme by the remote control (p. 14 or p. 22) → Swap again

#### Note

- Each input mode can only be displayed once (either on main screen or sub screen).
- The sound comes from only the main screen in multi window.
- You cannot change the aspect ratio in multi window.
- Multi window cannot be used with HDMI (available for main screen only), PC or SD Card.
- Some signals are reformatted for suitable viewing on your display.
- By pressing the GUIDE button and displaying the TV Guide you will exit multi window.
- If main screen has digital teletext signals, some key words may appear on the colour bar. In this case the operations can be performed by using colour buttons on the remote control except when the colour bar is displayed by pressing the button.

# Viewing Teletext

You can enjoy news, weather forecasts and subtitles, etc. (depending on the broadcaster)

- The availability of teletext services for a programme is indicated by "TXT" in the information banner.

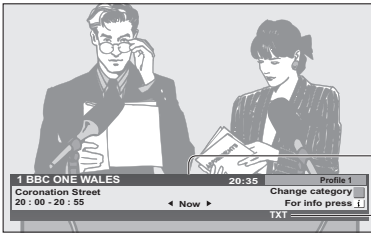

Information banner (p. 15)

Displayed if programme has teletext service

## DVB mode

### DVB teletext services

DVB teletext services differ greatly from analogue teletext.

When you switch to a DVB teletext service, the images you see can contain graphics and text, laid out and controlled in a manner decided by the broadcaster.

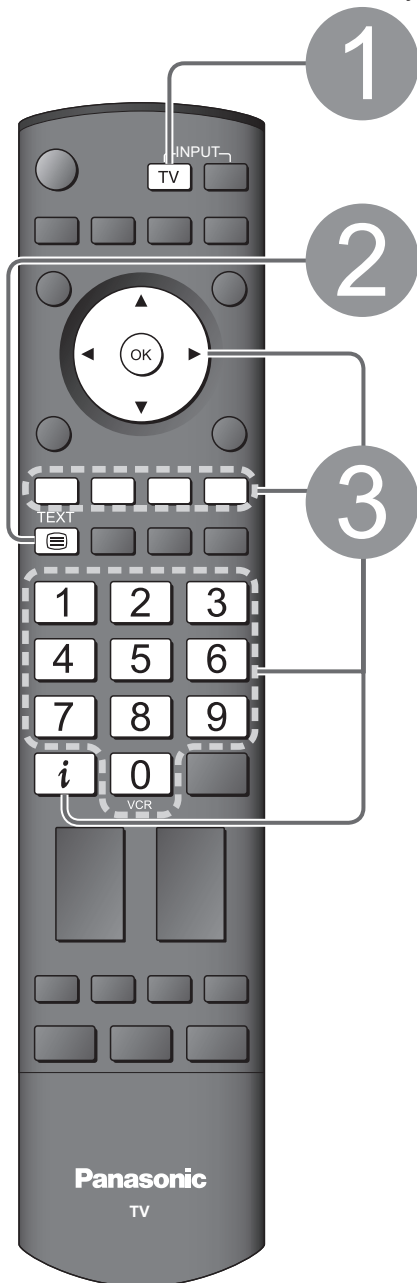

If in Analogue mode

### Select DVB



### Switch to Teletext

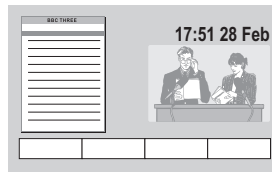

### How to use

In all cases, it is possible to navigate the pages using buttons on the remote control, but because the commands available must apply to all manufacturers of DVB equipment, some on screen commands may not correspond exactly to the remote control buttons.

For example:

- When "select" or "go" is displayed →
- When "◀", "▶", "▲", "▼" symbol is displayed →
- When the key words are displayed on colour bar →
- When options with numbers are displayed →
- When "i" is displayed → (information)

■ To return to TV →

### Note

- As soon as you switch to a DVB programme with links to a teletext service, software is downloaded in the background to enable the teletext function. This means that when switching to a DVB programme, you should wait for approximately 5 seconds before pressing the TEXT button - this will allow the software to download. If you press the TEXT button before download is complete, there will be a short delay before the text screen is displayed.
- While navigating DVB teletext, you will find there is a short delay when moving between pages while the page downloads. There is often a prompt shown somewhere on the page (for example "Loading") to let you know that this is happening.

# Viewing Teletext

## Analogue mode

### What is FASTEXT mode?

In FASTEXT mode, four differently coloured subjects are situated at the bottom of the screen. To access more information about one of these subjects, press the appropriately coloured button. This facility enables fast access to information on the subjects shown.

### What is List mode?

In List mode, four differently coloured page numbers are situated at the bottom of the screen. Each of these numbers can be altered and stored in the TV's memory. ("Store frequently viewed pages", p. 19)

■ **To change mode** → "Teletext" in Setup Menu (p. 27)

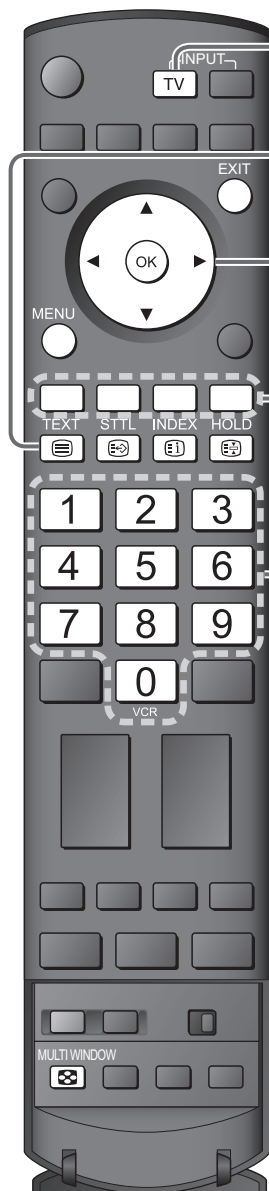

**1**

If in DVB mode  
**Select Analogue**



**2**

**Switch to Teletext**



● Displays the index page (content varies depending on the broadcasters)

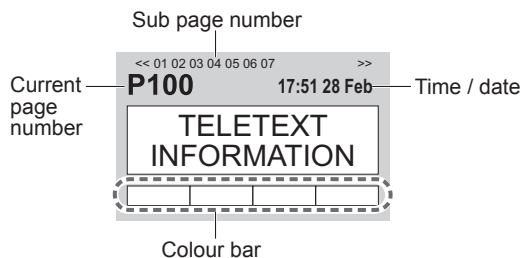

**3**

**Select the page**

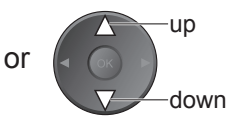

■ **To adjust contrast** → MENU (Press twice) →

■ **To return to TV** → EXIT

<b>Reveal hidden data</b>	Reveal hidden words e.g. quiz page answers MENU →  ■ <b>Re-hide</b> →
<b>FULL / TOP / BOTTOM</b>	MENU →  →  →  →  (Normal (FULL))

## HOLD

**Stop automatic updating**

(If you wish to hold the current page without updating)



■ To resume →



## INDEX

**Return to the main index page**

## Subtitles

**View subtitles**

● Factory setting is "P888" (subtitle service) on blue button (List mode).

## View in multi window

**Watch TV and Teletext in two windows at once**

MULTI WINDOW



● Operations can be made only in Teletext screen.

## Store frequently viewed pages

**Store frequently viewed pages in the colour bar**

(List mode only)

As page is displayed



Corresponding colour button



press and hold

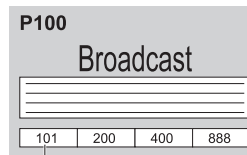

● If you wish to use Subtitles, do not change number on blue button.

## ■ To change stored pages



Colour button you want to change



Enter new page number



press and hold

The number changes to white.

## View sub page

**View sub page (Only when teletext is more than one page)**

&lt;&lt;01 02 03 04 05— Appears at top of the screen

## ■ To view specific sub page

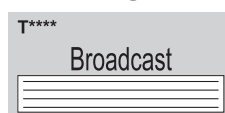
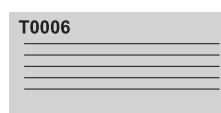

blue

Enter the 4-digit number  
example: P6

● Sub pages:

The number of sub pages varies depending on the broadcasters (up to 79 pages). It may take some time for searching, during which time you can watch TV.

## Watch TV while waiting for update

**View the TV picture while searching for a teletext page**

Teletext automatically updates itself when new information becomes available.

Changes to TV screen temporarily



yellow



Appears when updating is completed

yellow



View the updated page

(You cannot change the programme.)

● The news page provides a function that indicates arrival of latest news ("News Flash").

# Using TV Guide

TV Guide—Electronic Programme Guide (EPG) provides an on-screen listing of the programmes currently broadcast and the forthcoming broadcasts over the next seven days (depending on the broadcasters).

- This TV supports the GUIDE Plus+ system.
- The Gemstar branding partner will supply the rating informations in the event information and the recommended group in the Prog.Type list.
- Analogue programmes will be listed after DVB programmes. “D” means DVB programme and “A” means Analogue programme.
- When this TV is turned on for the first time, or the TV is switched off for more than a week, it may take some time before the TV Guide is completely shown.

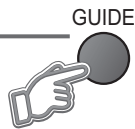
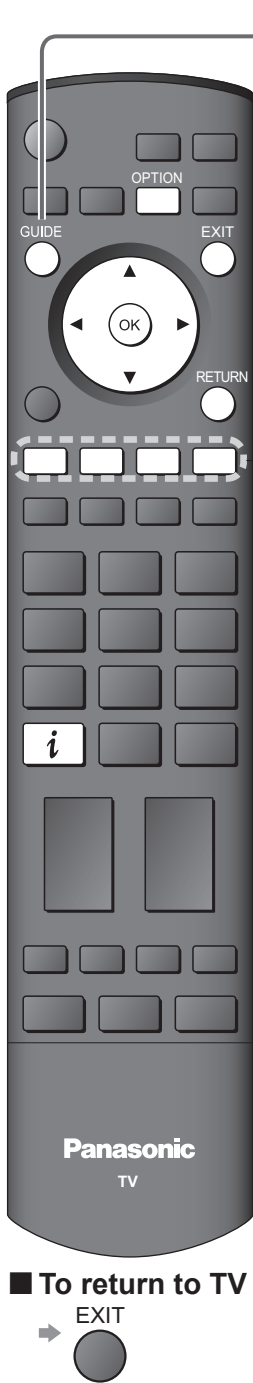

## View TV Guide (landscape or portrait)

View “Portrait” to see one programme at a time  
View “Landscape” to see many programmes

Example: TV Guide date Event Logo of the Gemstar branding partner

Current date and time: Wed 24/10/2007 10:46

TV Guide time: 20:00 - 20:30 DIY SOS: W... open in the Battersbys

Advertisement: **VIERA**

Programme:

Time	19:30	20:00	20:30	21:00
D 1 BBC ONE	Hot Wars	DIY SOS	DIY SOS	DIY SOS
D 7 BBC THREE	Eastender	DIY SOS	DIY SOS	DIY SOS
D 14 E4	Emmerdal.	Coronation Street	Coronation Street	Coronation Street
D 70 BBC FOUR	10 O' clock News BBC	Pepsi Char.	Pepsi Char.	Pepsi Char.
D 72 BBC 2W	Panorama	Spring watch	Spring watch	Spring watch
D 105 BBCi	I'm A Celebrity	Pop Idol	Pop Idol	Pop Idol
D 719 BBC Radi	Rugby	15 To 1	15 To 1	15 To 1

(TV Guide start page) Landscape (Displays by programme)

### To change the layout

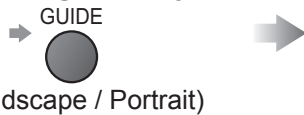

Example:

TV Guide: Portrait

Wed 24/10/2007 10:46

Wed 24th

19:30-20:00 Eastender

20:00-21:00 DIY SOS

21:00-22:00 The Bill

21:00-22:00 Red Cap

22:30-23:30 Live Junction

23:00-23:30 POP 100

23:00-00:00 Rugby

Portrait (Displays by time)

### To the previous day (DVB mode)



### To the next day (DVB mode)



### To view a programme list of the selected type (DVB mode)



Prog. Type

All Types

Movie

News

(Type list)

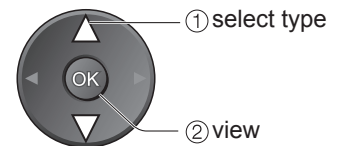

### To view a programme list of the selected category



Category

All Services

All DVB Services

All Analogue Services

Free Services

TV and Data Services

Profile 1

Profile 2

Profile 3

Profile 4

(Category list)

Only Analogue TV programmes are listed

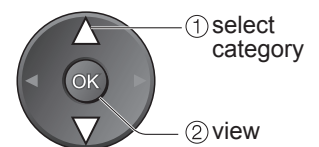

To list favourite programmes → p. 32

■ Other useful functions (Operate after viewing TV Guide)

**Watch the programme**

**Select the current event or programme**

**Select "View"**

● Timer Programming  
➔ see below

(TV screen)

**View details of the event (DVB mode)**

**Select the event**

**View details**

Details

■ **To return to the start page**

**Timer Programming**

**Select the forthcoming event to output to external recorder**

(Timer Programming screen)

Timer LED will turn on if Timer Programming is set.

Timer LED

- Orange Timer LED (Blinking during timer active)

■ **To check / change / cancel a Timer Programming event**

➔ "Timer Programming" (p. 41)

■ **To return to TV Guide** ➔

**Event recording (Timer Programming according to the TV Guide signal)**

Event recording is a timer programme controlled by information from the TV Guide. Programme start and end times may be changed by broadcasters and sent to the TV for timer programme to follow the change. Split Programme is a programme which is interrupted by one or more events. Both of the above are subject to signals being sent by broadcasters.

**Select the forthcoming event to output to external recorder**

"Guide" is displayed if the timer is set from the TV Guide

(Timer Programming screen)

Timer LED will turn on if Timer Programming is set.

Timer LED

- Orange Timer LED (Blinking during timer active)

■ **To check / change / cancel an Event recording event** ➔ "Timer Programming" (p. 41)

● If you edit the Event recording after setting to record, it will no longer be performed as Event recording. The recording will be performed according to the time setting in Timer Programming.

■ **To return to TV Guide** ➔

- Not available in Analogue mode.
- Whilst making Split Programme recording, it is not possible to record any events between sections.
- The Split Programme recording does not work if the separated parts are broadcast on differing channels.

**View advertisement**

Enter your postcode when using this function for the first time ➔ "Postcode" in "GUIDE Plus+ Settings" (p. 27)

If you have already entered your postcode in Owner ID (p. 12), you do not have to enter again. If you enter an incorrect postcode for your area, or no postcodes are entered, advertisement may not be displayed correctly.

**Display advertisement information**

OPTION ● To display the latest advertisement, you will need to update the information. To update the information continuously, the TV must be left in Standby mode at night.

● Some advertisements are for future programmes. In this case it is possible to use the Event recording function. ➔ see above

● The advertisements displayed on the TV Guide are sent from the GUIDE Plus+ system so that they cannot be deleted manually or will not be lost even when the TV is turned Off with Mains power On / Off switch.

■ **To change advertisements**

■ **To return to TV Guide**

➔ OR

# Watching VCR, DVD and Satellites

Connect the external equipment (VCRs, DVD equipment, etc.) and you can watch the input. Connect the Satellite receiver and you can watch satellite broadcasts.

● To connect the equipment → p. 10 and p. 11

The Remote Control is capable of operating some functions of selected Panasonic external equipment.



## 1 Turn the TV on

### ■ When connecting with SCART as example 2 or 3 (p. 10 and p. 11)

- ➔ Receives input signals automatically when playback starts or satellite receiver is switched on
- Input signals are automatically identified by the SCART (pin 8) terminal.
- This function is also available for HDMI connections (p. 50).

### ■ If input mode is not switched automatically

- ➔ Perform 2 and 3
- Dependant on the setup of the equipment

## 2 Display the Input select menu



## 3 Select the input mode connected to the equipment

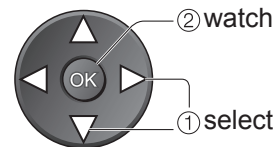
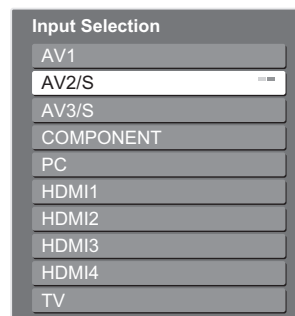

- You can also select the input using the AV button on the remote control or the front panel of the TV. Press the button repeatedly until the desired input is selected.
- You can label or skip each input mode → "Input Labels" (p. 38). Skipped inputs will not be displayed when AV button is pressed.

## 4 View

Displays the selected mode

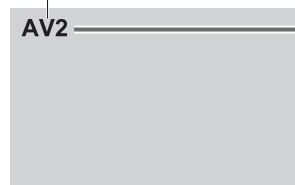

### ■ To return to TV



### Note

- If the external equipment has an aspect adjustment function, set to "16:9".
- For details, see the manual of the equipment or ask your local dealer.

## Screen display

Terminal	AV1	AV2	AV3	COMPONENT	PC	HDMI1	HDMI2	HDMI3	HDMI4
Manual input (default setting in "Input Labels")	AV1 AV1-RGB	AV2 AV2-S-Video AV2-RGB	AV3 AV3-S-Video	COMPONENT	PC	HDMI1	HDMI2	HDMI3	HDMI4
Auto input (EC mode or VIERA Link)	EC/AV1 EC/AV1-RGB	EC/AV2 EC/AV2-S-Video EC/AV2-RGB	—	—	—	EC/HDMI1 ● Applicable for EC mode and VIERA Link	EC/HDMI2 ● Applicable for VIERA Link	EC/HDMI3 ● Applicable for VIERA Link	EC/HDMI4 ● Applicable for VIERA Link

Panasonic equipment connected to the TV can be directly operated with the remote control.

	<b>VCR / DVD switch*</b> Select VCR to operate Panasonic VCR or DVD equipment Select DVD to operate Panasonic DVD equipment or Player home theatre
	<b>Standby</b> Set to Standby mode / Turn on
	<b>Play</b> Playback videocassette / DVD
	<b>Stop</b> Stop the operations
	<b>Rewind / Skip / Search</b> VCR: Rewind, view the picture rapidly in reverse DVD: Skip to the previous track or title Press and hold to search backward
	<b>Fast-forward / Skip / Search</b> VCR: Fast-forward, view the picture rapidly forward DVD: Skip to the next track or title Press and hold to search forward
	<b>Pause</b> Pause / Resume DVD: Press and hold to play at slow speed
	<b>Programme Up / Down</b> Select programme
	<b>Record</b> Start recording

### \*Setting your remote control to operate Panasonic VCR, DVD, etc.

① Set the VCR / DVD switch to the appropriate position → 

② Press and hold  during the following operations

Enter the appropriate code for the equipment to be controlled, see table below



→ Press 

"VCR" position

Equipment	Code
VCR	10 (default)
DVD	11

"DVD" position

Equipment	Code
DVD	70 (default)
Player home theatre	71

### Note

- Confirm if the remote control works correctly after changing the code.
- The codes will be reset to default values if batteries are replaced.
- "DVD" means DVD player, DVD recorders and Recorder home theatre.
- Some operations may not be possible on some equipment models.

# How to Use Menu Functions

Various menus allow you to make settings for the picture, sound, and other functions.

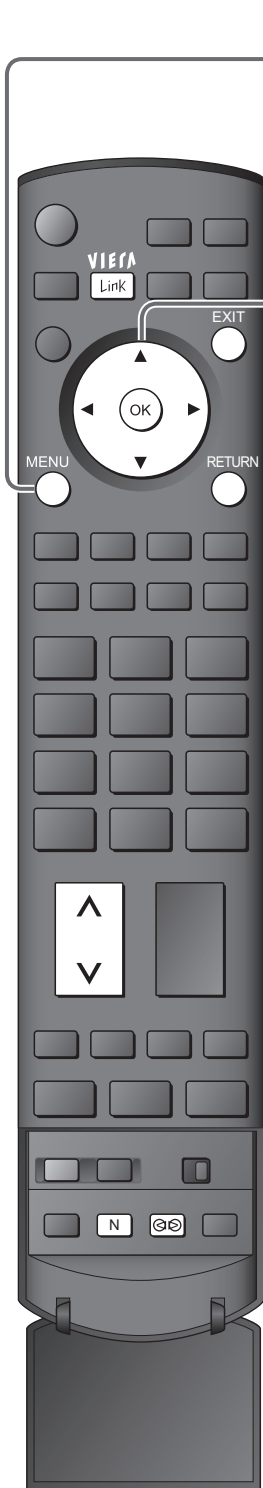

1

## Display the menu

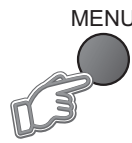

● Displays the functions that can be set (varies according to the input signal)

2

## Select the menu

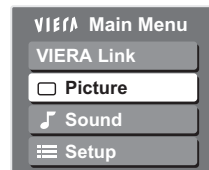

(example: Picture Menu)

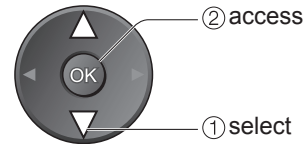

3

## Select the item

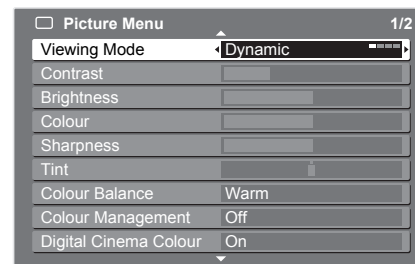

(example: Picture Menu)

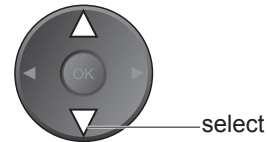

4

## Adjust or select

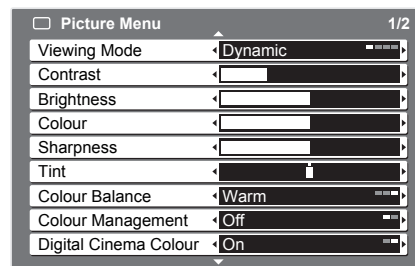

(example: Picture Menu)

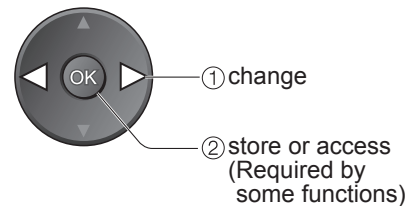

■ To return to TV at any time



■ To return to the previous screen



## ■ Choose from among alternatives

Number and positions of alternatives

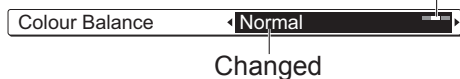

## ■ Adjust using the slide bar



## ■ Go to the next screen

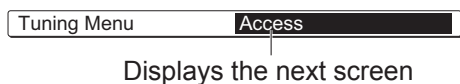

## ■ Enter characters using alpha / numeric keys

You can input information using alpha / numeric keys.

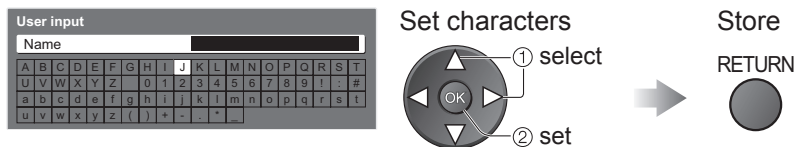

## ■ To change menu pages

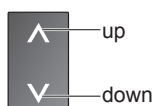

## ■ To reset the settings

- To reset the picture settings only
  - ➔ "Reset to Default" in Picture Menu (p. 26)
- To reset the sound settings only
  - ➔ "Reset to Default" in Sound Menu (p. 26)
- To reset the picture and sound settings together
  - ➔ **N** (Also volume level and aspect mode are reset)
- To initialize all settings
  - ➔ "Shipping Condition" in Setup Menu (p. 36)

# How to Use Menu Functions

## ■ Menu list

Menu	Item	Adjustments / Configurations (alternatives)	
VIERA Link	Pause Live TV	Controls the connected equipment with VIERA Link function, and enables various convenient recording, playback, etc. (p. 47 - 49) ● You can also access VIERA Link Menu directly using the VIERA Link button on the remote control.	
	Direct TV Rec		
	VIERA Link Control		
	Speaker Selection		
Picture	Viewing Mode	Selects four different screen settings ( <b>Dynamic / Normal / Cinema / Eco</b> ) Dynamic : Provides enhanced picture contrast and sharpness when viewing in a bright room Normal : Recommended for viewing under normal ambient room lighting conditions Cinema : For watching movies in a darkened room producing a cinema-like picture Eco : Adjusts picture settings automatically dependent on ambient lighting conditions In each Viewing Mode setting, Contrast, Brightness, Colour, Sharpness, Tint, Colour Balance, Colour Management and 3D-COMB can be adjusted and stored to suit your particular viewing requirement (e.g., you may require different settings for viewing sports, films, news etc.) ● Set for each input signal ● Changes will be stored automatically	
	Contrast, Brightness, Colour, Sharpness	Increases or decreases the levels of these options according to your personal preference	
	Tint	With an NTSC signal source connected to the TV, the picture hue can be adjusted to suit your taste ● For NTSC signal reception only	
	Colour Balance	Allows you to set the overall colour tone of the picture ( <b>Cool / Normal / Warm</b> )	
	Colour Management	Automatically adjusts colours to vivid ones ( <b>Off / On</b> ) ● Not valid on PC signal	
	Digital Cinema Colour	Displays the vivid images with the expanded colour gamut ( <b>Off / On</b> ) Set to "Off" if pictures contain Digital Cinema Colour signals, set to "On" if they do not contain Digital Cinema Colour signals Pictures containing Digital Cinema Colour signals can be, for example, created by an HD Video Camera ● Only available in HDMI input mode and SD Card Movie View Mode (p. 43)	
	P-NR	Picture Noise Reduction Automatically reduces unwanted picture noise and flicker noise in the contoured parts of a picture ( <b>Off / Min / Mid / Max</b> ) ● Not valid on PC signal	
	3D-COMB	Occasionally, whilst viewing still or slow moving pictures, colour patterning may be seen Set to "On" to display sharper and more accurate colours ( <b>Off / On</b> ) ● For PAL or NTSC signal reception only ● Not valid on RGB, S-Video, Component, PC, HDMI and SD Card	
	Reset to Default	Press the OK button to reset the present Picture Mode to the default settings	
	Sound	Mode	Select two different sound settings ( <b>Music / Speech</b> ) In each Sound Mode setting, Bass and Treble can be adjusted and stored to suit your particular sound requirement Changes to any settings in a mode will affect all signal sources Sound quality can be improved
Bass		Increases or decreases level to enhance or minimise lower, deeper sound output	
Treble		Increases or decreases level to enhance or minimise sharper, higher sound output	
Balance		Adjusts volume level of right and left speakers	
Headphone Volume		Adjusts the volume of the headphones	
Surround		Surround sound settings ( <b>Off / Simulated Surround / SRS TruSurround XT</b> ) Simulated Surround: Provides a dynamic enhancer to simulate improved spatial effects SRS TruSurround XT: SRS TruSurround XT® creates a high quality surround sound effect using just two speakers from the source which can output surround encoded signals ● Switching is also possible by the Surround button on the remote control (p. 9).	
Volume Correction		Adjusts volume of individual programme or input mode	
Speaker Distance to Wall		Adjusts the low frequency sound ( <b>Over 30cm / Up to 30cm</b> ) ● If the back space between the TV and wall is over 30 cm, "Over 30cm" is recommended. ● If the back space between the TV and wall is within 30 cm, "Up to 30cm" is recommended.	
Preferred Multi Audio		Selects the preferred language for DVB multi audio (depending on the broadcaster)	
NICAM		NICAM (Near Instantaneous Companded Audio Multiplex) A format for digital sound over television Reproduces stereo sound ( <b>Off / On</b> ) ● Off if reception is poor (FM monaural sound) ● Analogue mode only	
HDMI1 / 4 Input		Select to fit the input signal ( <b>Auto / Digital / Analogue</b> ) (p. 52) Auto : Automatic detection of digital or analogue sound source Digital : HDMI cable connection Analogue : HDMI-DVI adapter cable connection ● HDMI input mode only ● HDMI2 / 3 terminals are for digital signal only ● No setting for HDMI2 / 3 available	
Audio Description Menu		Audio Description	Useful for visually-impaired viewers ( <b>Off / On</b> ) Select "On" to activate the description sound track if available
		Volume	Adjusts the volume for audio description
	Speakers	Set to "On" to activate the description sound track from TV speakers ( <b>Off / On</b> )	
	Headphones	Set to "On" to activate the description sound track from headphones ( <b>Off / On</b> )	
Reset to Default	Press the OK button to reset the present Sound Mode to the default settings ● Effective to Bass, Treble, Balance, Headphone Volume and Surround		

## Menu list

Menu	Item	Adjustments / Configurations (alternatives)	
Setup	Timer Programming	Records forthcoming programmes (p. 40)	
	DVB Profile Edit	Creates list of favourite DVB programmes (p. 32)	
	DVB Service List	Skips the unwanted DVB programmes (p. 33)	
	Analogue Service List	Skips the unwanted Analogue programmes or edits Analogue programmes (p. 33)	
	Link Settings	VIERA Link	Sets to use VIERA Link functions ( <b>Off / On</b> ) (p. 46)
		Q-Link	Selects which AV terminal is to be used for data communication between this TV and a compatible recorder ( <b>AV1 / AV2</b> ) (p. 45) ● Select the connected terminal to the recorder even it is not compatible with Q-Link.
		AV1 / AV2 out	Chooses the signal to be transmitted from the TV to Q-Link ( <b>TV / AV1 / AV2 / AV3 / Monitor</b> ) ● Monitor: Image displayed on screen ● Component, PC and HDMI signals cannot be outputted.
		Q-Link Download	Downloads analogue programme information to a Q-Link compatible equipment connected to the TV
	Child Lock	Locks a programme / AV input to prevent access to it (p. 33)	
	Tuning Menu	Auto Setup	Automatically sets the programmes received in the area (p. 35)
		DVB Manual Tuning	Sets the DVB programmes manually (p. 35)
		Analogue Manual Tuning	Sets the Analogue programmes manually (p. 35)
		Add New DVB Services	Adds new DVB services (p. 35)
		New Service Message	Selects whether to give a notification message when a new DVB service is found (p. 35)
		DVB Signal Condition	Checks the DVB signal condition (p. 35)
	GUIDE Plus+ Settings	Postcode	Sets your postcode to display advertisements in the GUIDE Plus+ system (p. 20)
		System Information	Displays the system information of the GUIDE Plus+ system
	Intelligent Frame Creation	Automatically compensates the picture frame rate to make the image smooth ( <b>Off / On</b> ) ● It is effective when viewing 24p input signal with this function set to "On". ● Not valid on PC signal	
	Off Timer	Sets the time the TV automatically turns Off ( <b>Off / 15 / 30 / 45 / 60 / 75 / 90 minutes</b> )	
	Power on Preference	Set to "TV" to view picture from TV tuner. Set to "AV" to view input from an external equipment connected to a SCART terminal, e.g. satellite receiver ( <b>TV / AV</b> ) ● The external equipment must be switched on and sending a control signal for automatic switching at power on to occur.	
	Teletext	Analogue teletext display mode ( <b>FASTTEXT / List</b> ) (p. 18)	
	Preferred Subtitles	Selects the preferred language for DVB subtitles (depending on the broadcaster) ● To display subtitles ➔ p. 14	
	Shipping Condition	Resets all settings, for example, when moving house (p. 36)	
	Owner ID	Inputs the owner ID (p. 37)	
	Common Interface	Uses include to watch pay-TV (p. 31)	
	System Update	Downloads new software to TV (p. 31)	
	Power Save	Reduces brightness of picture to economise on power consumption ( <b>Off / On</b> )	
	Side Panel	Increases the brightness of the side panel ( <b>Off / Low / Mid / High</b> ) ● The recommended setting is "High" to prevent panel "image retention".	
	Picture Overscan	Selects the screen area displaying the image ( <b>Off / On</b> ) On : Enlarged the image to hide the edge of the image. Off : Displayed the image in the original size. ● Set to "On" if noise is generated on the edge of the screen. ● This function is available when aspect is set to Auto (16:9 signal only) or 16:9. ● This function can be memorized separately for SD (Standard definition) and HD (High definition) signals.	
	Input Labels	Labels or skips each input terminal (p. 38)	
Banner Display Timeout	Sets how long the information banner (p. 15) stays on screen ● 0 (No display) to 10 sec. in 1-sec. increments		
SD Card LED	Lights blue LED while SD Card is inserted ( <b>Off / On</b> ) (p. 43)		
Software Licence	Displays the software licence information		
System Information	Displays the system information of this TV		

- A different menu will be displayed while PC or SD Card is used. (p. 39 and p. 43)
- Only available items can be selected.

# How to Use Menu Functions

## Overview

● How to operate (p. 24)

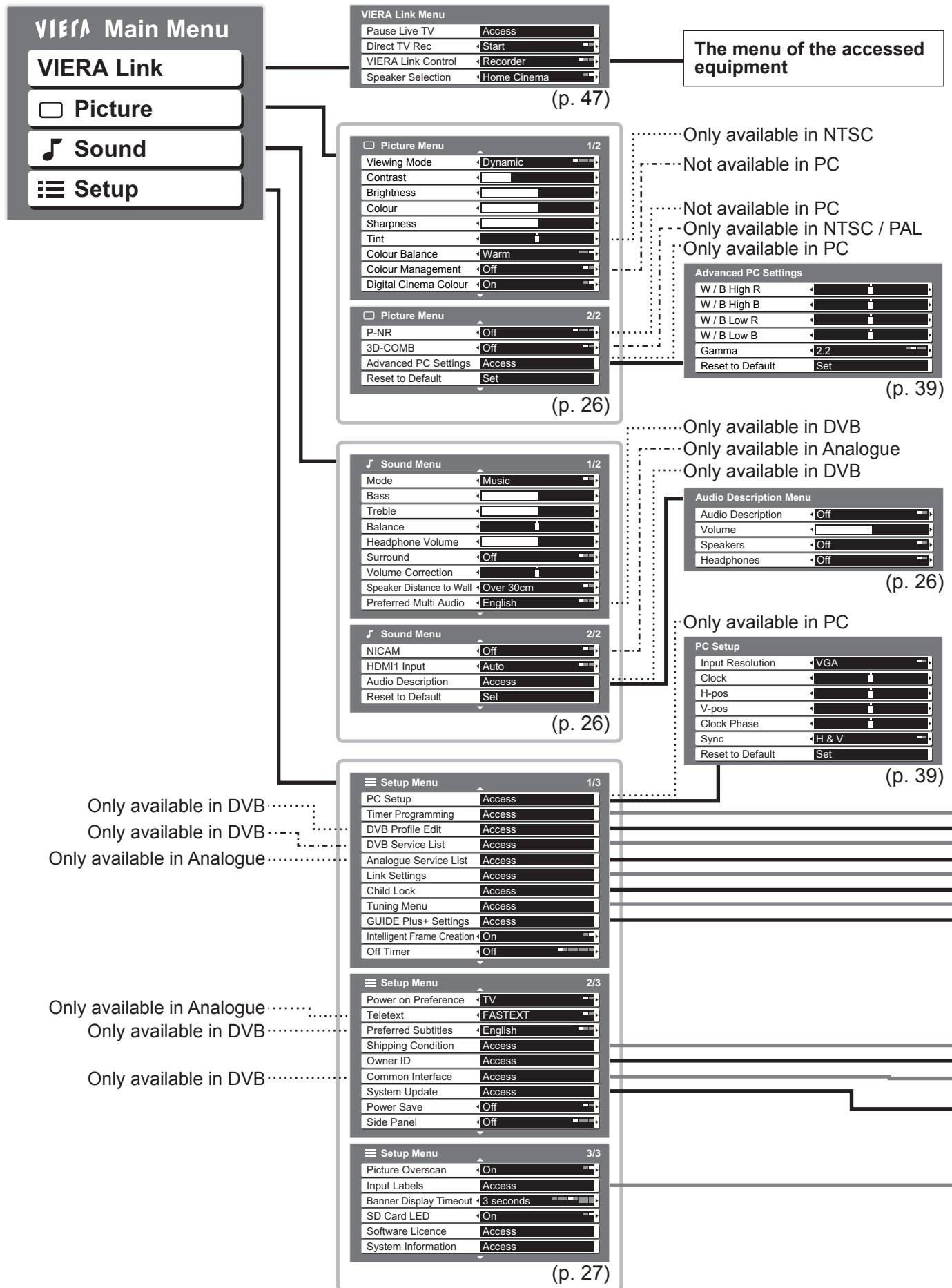

Timer Programming Wed 05/05/04 18:50

Pos.	Name	Date	Start	End	min.	
D 1	BBC1	6/8 FR	18:00	20:00	120	Off
D 1	BBC1	7/8 SA	21:30	22:30	60	Off
D 3	ITV1	7/8 SA	22:30	23:30	60	Off
---	---	---	---	---	---	---

(p. 40)

Profile Editor

All DVB Services	Profile 1
1 BBC One Wales	
7 BBC THREE	
14 E4	
70 CBBC Channel	
72 Cartoon Nwk	
105 BBCi	
719 BBC Radio Wales	
720 BBC Radio Cymru	

(p. 32)

DVB Service List

70 CBBC Channel	<input checked="" type="checkbox"/>
72 Cartoon Nwk	<input checked="" type="checkbox"/>
105 BBCi	<input checked="" type="checkbox"/>
719 BBC Radio Wales	<input type="checkbox"/>
720 BBC Radio Cymru	<input type="checkbox"/>
1 BBC ONE Wales	<input checked="" type="checkbox"/>
7 BBC THREE	<input checked="" type="checkbox"/>

(p. 33)

Analogue Service List

1 BBC1	<input checked="" type="checkbox"/>
2 *****	<input type="checkbox"/>
3 *****	<input type="checkbox"/>
4	<input type="checkbox"/>
5	<input type="checkbox"/>
6	<input type="checkbox"/>
7	<input type="checkbox"/>

(p. 33)

Link Settings

VIERA Link	On
Q-Link	AV2
AV2 out	TV
Q-Link Download	Access

(p. 27)

Child Lock

Change PIN	Access
Child Lock List	

(p. 33)

Only available in DVB  
 Only available in Analogue  
 Only available in DVB  
 Only available in DVB  
 Only available in DVB

Tuning Menu

Auto Setup	Access
DVB Manual Tuning	Access
Analogue Manual Tuning	Access
Add New DVB Services	Access
New Service Message	On
DVB Signal Condition	Access

(p. 34)

Auto Setup - Digital

Channel	Service Name	Type	Quality
62	CBBC Channel	Free TV	10
62	BBC Radio Wales	Free TV	10
62	E4	Free TV	10
62	Cartoon Nwk	Free TV	10

Free TV: 4 Pay TV: 0 Radio: 0 Data: 0 Searching

(p. 35)

DVB Manual Tuning

Frequency	474 MHz
Signal Quality	10
Signal Strength	10
Position	0
Service Name	
Type	
New	

Free TV: 0 Pay TV: 0 Radio: 0 Data: 0 Stopped

(p. 35)

Analogue Manual Tuning

1 BBC1	CH33
Manual Tuning	21

(p. 35)

Add New DVB Services

Channel	Service Name	Type	Quality

Free TV: 0 Pay TV: 0 Radio: 0 Data: 0 Searching

(p. 35)

DVB Signal Condition

DVB Programme	[CH70] CBBC Channel
Signal Quality	0 10
Signal Strength	0 10

(p. 35)

GUIDE Plus+ Settings Menu

Postcode	Access
System Information	

(p. 27)

Shipping Condition

All tuning data will be erased  
 Are you sure?  
 Are you sure?

(p. 36)

Owner ID

Please enter new PIN	
PIN	*****

(p. 37)

Common Interface

Slot 1:	Module inserted
---------	-----------------

(p. 31)

System Update

Auto Update Search in Standby	On
System Update Search Now	

(p. 31)

Input Labels

AV1	DVD
AV2/S	AV2/S
AV3/S	AV3/S
COMPONENT	COMPONENT
PC	PC
HDMI1	HDMI1
HDMI2	HDMI2
HDMI3	HDMI3
HDMI4	HDMI4

(p. 38)

# DVB Settings (DVB mode)

DVB Settings provide access to various advanced features.

**1** If in Analogue mode  
**Select DVB**

**2** Display the menu

**3** Select "Setup"

**4** Select one of the following functions

**5** Set

■ To return to TV  
EXIT

TV

MENU

OK

Setup Menu 2/3

Power on Preference	TV
Teletext	FASTEXT
Preferred Subtitles	English
Shipping Condition	
Owner ID	
Common Interface	Access
System Update	Access
Power Save	Off
Side Panel	Off

access

select

access

select

## Pay-TV

### Common Interface

The Common Interface Module menu provides access to software contained on Common Interface (CI) Modules.  
This TV receiver works only Pay TV modules complying with CI standard.

#### Caution

- Turn Off Mains power On / Off switch whenever inserting or removing the CI module.
- If a view card and a card reader come as a set, first insert the card reader, then insert the view card into the card reader.
- Do not insert the module up side down.

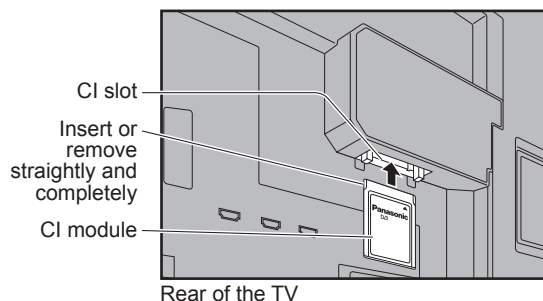

#### ① Insert the CI module (optional)

- The features that appear on screen are dependent on the contents of the selected CI module.
- Normally pay-TV services will appear without ② and ③. If pay-TV service does not appear, perform ② and ③.
- For more details, see the manual of the CI module, or check with the broadcaster.

#### ② Access "Common Interface"



#### ③ Follow the on-screen instructions



- On-screen operation guide may not correspond to the remote control buttons.

Download new software to TV.

- For details → p. 53

**If System Update is performed, the software will be updated (it may change TV functions). If you do not wish to do so, set "Auto Update Search in Standby" to Off.**

#### Select "Auto Update Search in Standby" and then set "On" or "Off"

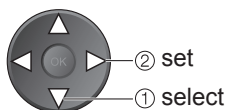
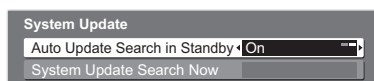

- On: Automatically performs a search in standby and downloads an update, if any software updates are available

#### ■ To update immediately

Select "System Update Search Now"

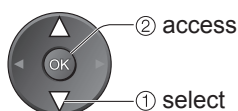

Searches for an update (for several mins.) and displays a corresponding message if any

Download



- Download may take up to 20 mins.

## Update TV's software system

### System Update

# Editing Programmes

You can make your favourite programme lists, skip unwanted programmes and control programme audience, etc.

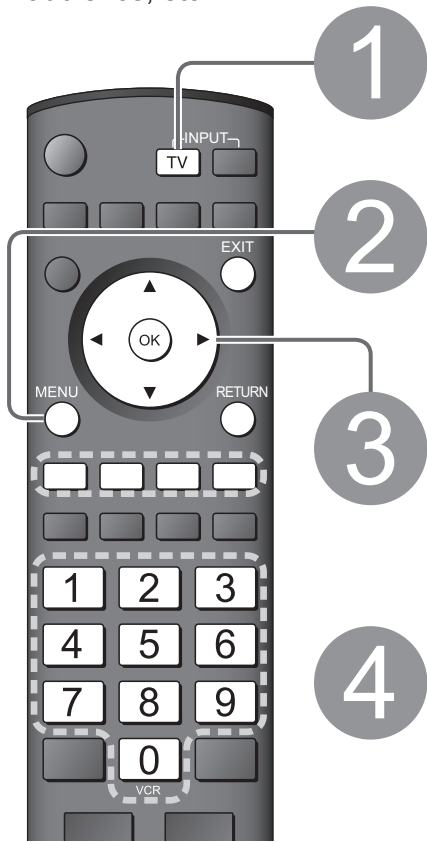

## 1 Select DVB or Analogue



## 2 Display the menu

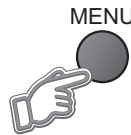

## 3 Select "Setup"

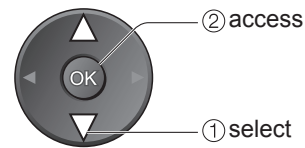

## 4 Select one of the following functions and set

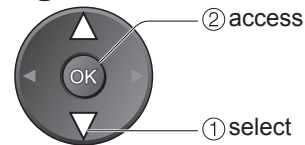
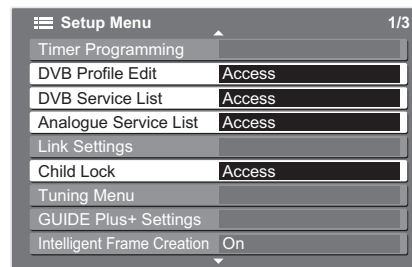

- "DVB Profile Edit" and "DVB Service List" are available in DVB mode only.
- "Analogue Service List" is available in Analogue mode only.

### To return to TV



Create your favourite programme list (Profile) from various broadcasters (up to 4: Profile 1 to 4).

The list is added to "Category" in TV Guide (p. 20) and information banner (p. 15) and then easily accessed.

### Select a programme and add it to the list

Profile Editor	All DVB Services	Profile 1
1	BBC One Wales	
7	BBC THREE	
14	E4	
70	CBBC Channel	
72	Cartoon Nwk	
105	BBC	
719	BBC Radio Wales	
720	BBC Radio Cymru	

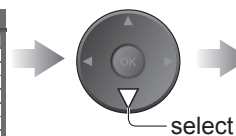

Profile Editor	All DVB Services	Profile 1
1	BBC One Wales	1 BBC One Wales
7	BBC THREE	
14	E4	
70	CBBC Channel	
72	Cartoon Nwk	
105	BBC	
719	BBC Radio Wales	
720	BBC Radio Cymru	

To change the category → red

To display another Profile → blue

To add all programmes to the list → yellow

A programme is added

List favourite programmes

**DVB Profile Edit**  
(DVB mode)

### To edit Profile



Select the field of Profile to edit and:

• To name the Profile → red → Select the character → OK → RETURN

• To move the programme → green → Select the new position → Confirm → green → OK

• To delete the programme → yellow → OK

• To delete all programmes → blue → OK

### Note

- Programme numbers (known as logical channel numbers) cannot be changed, due to broadcast restrictions.

Skip unwanted programmes

DVB Service List

Analogue Service List

You can hide unwanted services. The deleted services cannot be displayed except in this function. Use this function to skip unwanted programmes.

- “DVB Service List” lists all the tuned DVB programmes in DVB mode.
- “Analogue Service List” lists all the tuned Analogue programmes in Analogue mode.

Select a service and add / delete

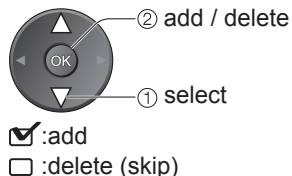
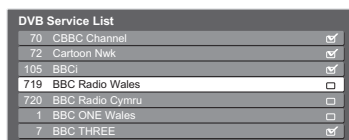

- To retune each programme (Manual Tuning) → red (p. 35)

Edit analogue programmes (Change name, Move)

Analogue Service List

You can change the programme name and programme position for Analogue programmes.

- This function is available in Analogue mode.
- If a VCR is connected only with the RF cable, edit “VCR”.

① Select the programme to edit

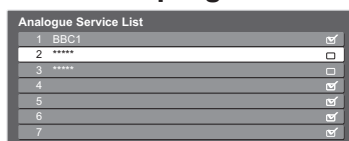

Programme position

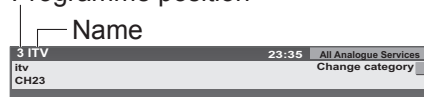

② Edit

■ To change the name displayed when selecting programmes

Select “Rename”



Set characters

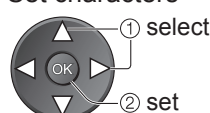

(maximum: five characters)

Store



■ To move the programme position

Select new position



Store



Control programme audience

Child Lock

You can lock specific programmes / AV input terminals and control who watches them. (When the locked programme / input is selected, a message appears; by entering the PIN number, you can watch it.)

① Enter the PIN number (4 digits)



- Enter the PIN number twice at first setting.
- Make a note of the PIN number in case you forget it.

② Select “Child Lock List”

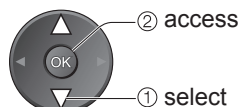

③ Select the programme / input to be locked

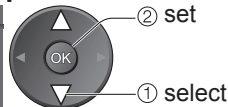
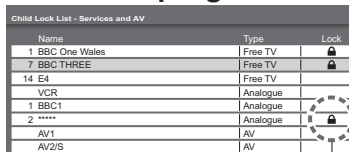

- To cancel → Select the locked programme / input → OK
- To lock all → yellow
- To cancel all locks → blue

Appears when the programme / input is locked

■ To change the PIN number

Select “Change PIN” in ② and enter a new PIN number twice.

Note

- Setting “Shipping Condition” (p. 36) erases the PIN number and all settings.

# Tuning Programmes

You can retune all the TV programmes when moving house or search for new services which may have recently started broadcasting.

**1 Select DVB or Analogue**  
 TV

**2 Display the menu**  
 MENU

**3 Select "Setup"**  

VIERA Main Menu
VIERA Link
Picture
Sound
<b>Setup</b>

**4 Select "Tuning Menu"**  

Setup Menu	1/3
Timer Programming	
DVB Profile Edit	
DVB Service List	
Link Settings	
Child Lock	
<b>Tuning Menu</b>	Access
GUIDE Plus+ Settings	
Intelligent Frame Creation	On
Off Timer	Off

**5 Select one of the following functions**  

Tuning Menu	
<b>Auto Setup</b>	Access
DVB Manual Tuning	Access
Analogue Manual Tuning	Access
Add New DVB Services	Access
New Service Message	On
DVB Signal Condition	Access

- "DVB Manual Tuning", "Add New DVB Services", "New Service Message" and "DVB Signal Condition" are available in DVB mode only.
- "Analogue Manual Tuning" is available in Analogue mode only.

**6 Set**

■ **To return to TV**  
 EXIT

■ **For Auto Setup, using the buttons on the front of the TV (p. 9)**

- Press repeatedly until "Auto Setup" appears  
 F
- Access "Auto Setup"  
 TV
- Start "Auto Setup"  
 TV

● To return to TV →  F

Set all DVB or Analogue programmes automatically

**Auto Setup**

Automatically retune all DVB or Analogue programmes received in the area.

- Only DVB programmes are retuned in DVB mode.
- Only Analogue programmes are retuned in Analogue mode.
- If a Child Lock PIN number (p. 33) has been set, it must be entered.

**Start Auto Setup**

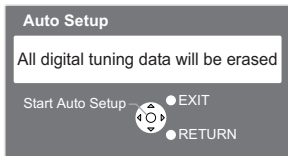

**Settings are made automatically**

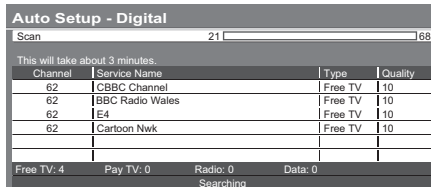

- All the previous tuning settings are erased.
- The analogue settings are downloaded to a Q-Link compatible equipment connected to the TV in Analogue mode.
- When the operation is completed, the programme at programme position "1" will be displayed.
- If tuning has not been done completely → "DVB Manual Tuning", "Analogue Manual Tuning"

Set DVB programme manually

**DVB Manual Tuning**

Normally use "Auto Setup" or "Add New DVB Services" to add DVB programmes to your service list. If tuning has not been done completely or for adjusting the direction of the aerial, use this function.

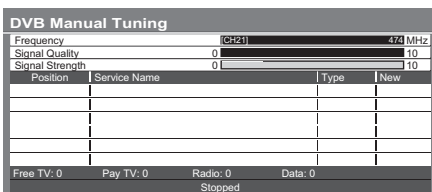

- All services found will be added to the DVB Service List.

Set Analogue programme manually

**Analogue Manual Tuning**

Set Analogue programme manually after Auto Setup.

- If a VCR is connected only with the RF cable, select programme position "0".



Select the programme position



Select the channel



Search and store

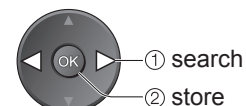

Any new services found will be added to the DVB Service List.

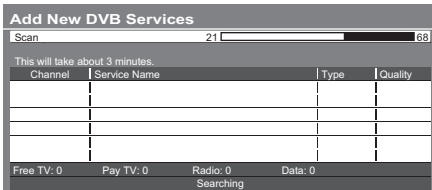

- The new service is added with the current settings saved as they are.

Display a notification message

**New Service Message**

Selects whether to give a notification message when a new DVB service is found. **(Off / On)**

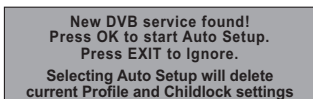

- Selecting OK (Auto Setup) will delete the current Profile and Childlock settings.

Check DVB signal

**DVB Signal Condition**

Selects a programme and checks the DVB signal condition.

- To change the programme

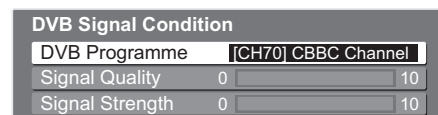

A good Signal Strength is not an indication of suitable signal for DVB reception. Please use the Signal Quality indicator as follows:

**Signal Quality:**

- Green bar → Good
- Yellow bar → Poor
- Red bar → Bad (Check the aerial)

# Shipping Condition

Resets the TV to its original condition, i.e. no programmes tuned in.  
All settings other than "Owner ID" (programmes, picture, sound quality, etc.) are reset.

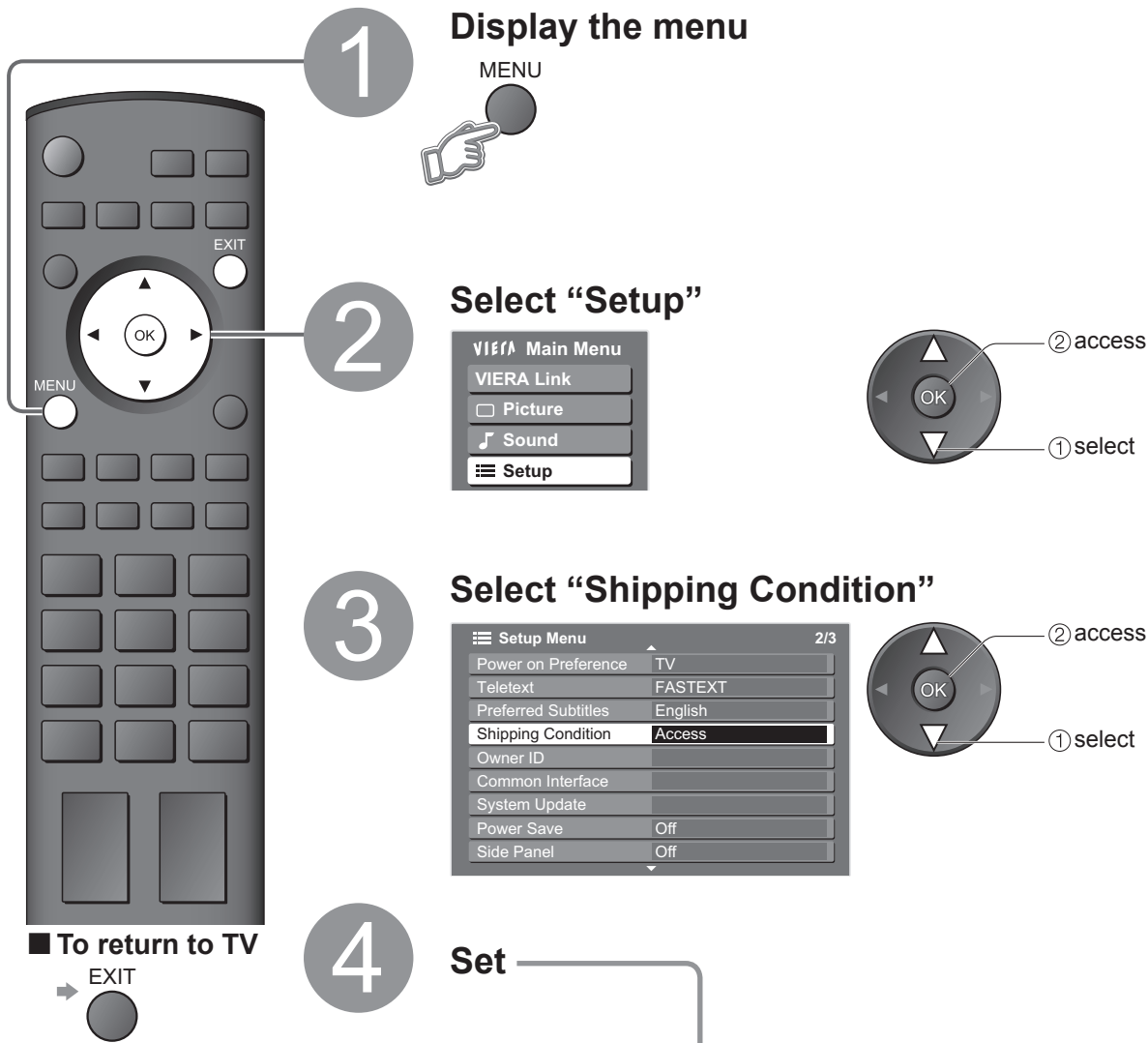

**Restore Settings**

**Shipping Condition**

**① Check the message and initialise**

Shipping Condition  
All tuning data will be erased  
Are you sure?  
Are you sure?  
Confirm: ●EXIT ●RETURN

**② Follow the on-screen instructions**

- "Auto Setup" will automatically start when Mains power On / Off switch is next turned On. (p. 12)

■ To retune TV programmes only, e.g. after moving house  
➔ "Auto Setup" (p. 35)

The 'Restore Settings' section shows a screenshot of the TV screen displaying a warning message: 'Shipping Condition: All tuning data will be erased. Are you sure? Are you sure?'. Below the message are two options: 'EXIT' and 'RETURN'. The 'RETURN' option is highlighted. The text below explains that following the on-screen instructions will start 'Auto Setup', which erases tuning data. A note specifies that 'Auto Setup' is used for retuning TV programmes only, such as after moving house.

# Owner ID

Entry of the security code (PIN number) and “personal information” (your name, address and postcode). In the unfortunate event of theft it will help the Police to determine the owner. If you have skipped the Owner ID input in “Auto Setup” (p. 12), and input it later, start from ①. If you input the Owner ID in “Auto Setup” (p. 12), perform ④.

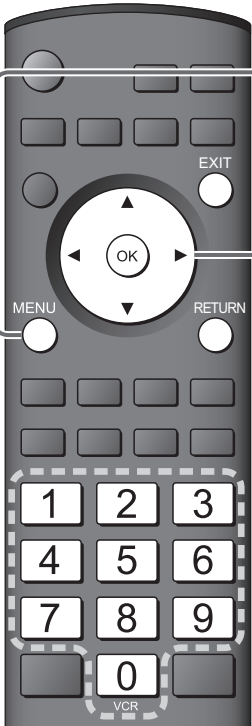

## 1 Display the menu

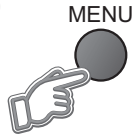

## 2 Select “Setup”

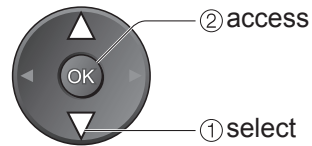
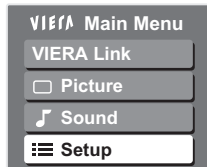

## 3 Select “Owner ID”

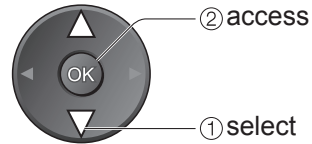
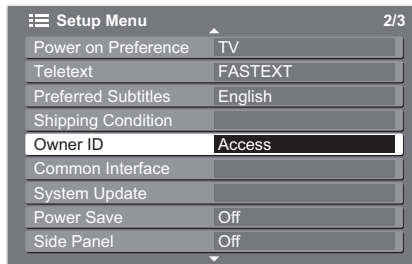

### ■ To return to TV



## 4 Set

### ① Enter the PIN number (4 digits)

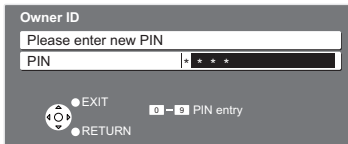

- Enter the PIN number twice at first setting.
- Make a note of the PIN number in case you forget it.

### ② Enter your name, address, and postcode, in that order

- Select the entry field
- Enter the “User input” mode
- Select the character
- Set
- Store

#### To check the “personal information” stored

Hold down for about 6 sec.  F

Displays the information on the screen (for several sec.)

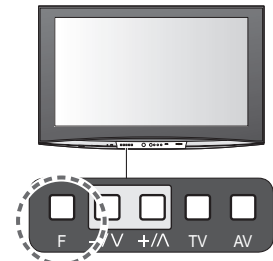
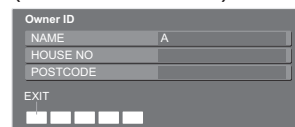

- The PIN number is not displayed.

### ■ To change the PIN number



➔ Enter a new PIN number twice

Input owner ID  
**Owner ID**

# Input Labels

For easier identification and selection of the input mode, you can label each input terminals or skip terminal that is not connected to any equipment.

● To select the input mode → p. 22

**1 Display the menu**  
 MENU

**2 Select "Setup"**  
 VIERA Main Menu  
 VIERA Link  
 Picture  
 Sound  
 Setup

**3 Select "Input Labels"**  
 Setup Menu 3/3  
 Picture Overscan On  
 Input Labels Access  
 Banner Display Timeout 3 seconds  
 SD Card LED On  
 Software Licence  
 System Information

**4 Select a input terminal and set**  
 Input Labels  
 AV1 DVD  
 AV2/S AV2/S  
 AV3/S AV3/S  
 COMPONENT COMPONENT  
 PC PC  
 HDMI1 HDMI1  
 HDMI2 HDMI2  
 HDMI3 HDMI3  
 HDMI4 HDMI4

■ To return to TV



The labels you set will be displayed in "Input Selection" menu (p. 22) or banner.  
 ● If "Skip" is selected, you cannot select the mode.

■ User input

You can name each input terminals freely.

Select "User input"

Set characters

Store

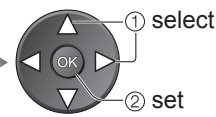
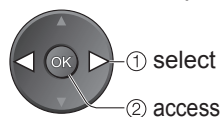

(maximum: ten characters)

# Displaying PC Screen on TV

The screen of the PC connected to the TV can be displayed on the TV.  
You can also listen to PC sound with the audio cable connected.

- To connect PC → p. 50

**1 Select the external input**



**2 Select "PC"**



**Input Selection**

- AV1
- AV2/S
- AV3/S
- COMPONENT
- PC**
- HDMI1
- HDMI2
- HDMI3
- HDMI4
- TV

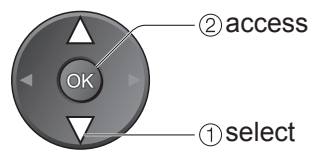

- Corresponding signals → p. 54
- If "H-freq." or "V-freq." is shown in red, the signals may not be supported.

■ To return to TV



■ PC menu setting (changed as desired)

- To make settings → "How to Use Menu Functions" ① to ④ (p. 24)

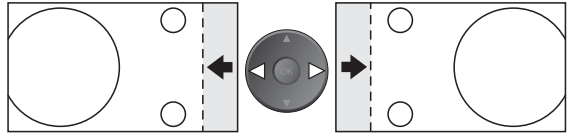
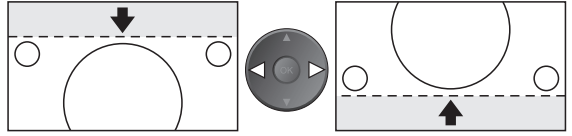
Menu	Item	Adjustments / Configurations (options)
Picture	W/B High R	White balance of bright red area
	W/B High B	White balance of bright blue area
	W/B Low R	White balance of dark red area
	W/B Low B	White balance of dark blue area
	Gamma	<b>(S Curve / 2.0 / 2.2 / 2.5)</b>
	Reset to Default	Press the OK button to reset to the default Picture settings
Setup	Input Resolution	Switches to a wide view ● VGA (640 × 480 pixels), WVGA (852 × 480 pixels), XGA (1,024 × 768 pixels), WXGA (1,366 × 768 pixels) ● Options change depending on signals
	Clock	Set to the minimum level if noise occurs
	H-pos	Adjusts horizontal position 
	V-pos	Adjusts vertical position 
	Clock Phase	Eliminates flicker and distortion ● Adjust after Clock adjustment ● Set to the minimum level if noise occurs
	Sync	Chooses another synchronous signal if the image is distorted ( <b>H &amp; V / On G</b> ) ● H & V : by the horizontal and vertical signals from your PC On G : by the green signal from your PC (if available)
	Reset to Default	Press the OK button to reset to the default Setup settings

- Other items → p. 26 and p. 27

# Recording Controls

## Timer Programming from Menu

The Timer programming menu allows you to choose programmes that you wish to record. At the correct time, the TV will switch on and tune to the correct programme (even if the TV is in Standby mode). TV Guide may also be used to set timer programming. (p. 20)

- If the recorder is compatible with Q-Link or similar technologies (p. 45), and setup / connection are done completely (p. 44 and p. 45), you do not need to programme the recorder – the TV will control the recording progress.
- If the recorder is not compatible with Q-Link or similar technologies, set “Q-Link” in Setup Menu (p. 27) to the connected terminal (AV1 or AV2), and make timer programming of the recorder (Read the manual of the recorder).
- Recording is possible in composite video via SCART only - including HD content.
- While recording, you cannot watch any other programmes except the one being recorded.

- 1 Select the mode you want to set a recording**  
 TV
- 2 Display the menu**  
 MENU
- 3 Select “Setup”**  

VIERA Main Menu
VIERA Link
Picture
Sound
<b>Setup</b>
- 4 Select “Timer Programming”**  

Setup Menu	1/3
<b>Timer Programming</b>	Access
DVB Profile Edit	
DVB Service List	
Link Settings	
Child Lock	
Tuning Menu	
GUIDE Plus+ Settings	
Intelligent Frame Creation	On
Off Timer	Off
- 5 Set**
- 6 Store**  
 OK

**■ To return to TV**  
 → EXIT →

**■ To stop recording**  
 → GUIDE → EXIT → →

### Caution

- The TV must either be On or in standby.
- For preparations of a recorder, read the manual of the recorder.
- No other programme can be selected during recording.
- It may not be possible to record an encrypted programme (which is copy-protected).

## Set timer programming details

① Start making the settings



② Repeat the operations as below, and set items in the order of ① to ⑤



select the item



set

● ①, ③ and ④ can also be entered with numeric buttons.

D: DVB  
A: Analogue  
(you cannot change TV mode within the menu)

Timer recording  
Records according to the time setting

Guide: Event recording  
Records according to the TV Guide signal (p. 21)

S/P: Split Programme (p. 21)

Displayed if the timer programming events are overlapped

Current timer programming event

Pos.	Name	Date	Start	End	min.	
D 7	BBC THREE <TIMER>	6/8 FR	17:00	18:30	90	Off
D 1	BBC1 Holiday News	6/8 FR	18:00	20:00	120	Off
D 3	ITV1 Freshly Squeezed Extra	7/8 SA	21:30	22:30	60	Off
...	...	...	...	...	...	...

① Programme

② Date

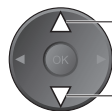

one day ahead

daily or weekly  
(press repeatedly)

⑤ Subtitles (Off / Auto)

● Recording time  
(automatic display)

④ Ending time

③ Starting time

- Daily SU-SA: Sunday to Saturday
- Daily MO-SA: Monday to Saturday
- Daily MO-FR: Monday to Friday
- Weekly SA/FR/TH/WE/TU/MO/SU: Same time on the same day every week

### ■ To change a timer programming event

➔ Select the programme to be changed



② access

① select

➔ Correct as necessary  
(as above)

### ■ To cancel a timer programming event

➔ Select the programme to be deleted



red



### ■ To cancel a timer programming event temporarily

➔ Select the programme to be cancelled



blue

● Each time pressed:  
cancel ↔ stop cancelling

### ■ To view details of the programming

➔ Select the programme to be viewed



● Press again to return to  
Timer Programming menu.

### ■ Event recording (Timer Programming from TV Guide-EPG) ➔ p. 21

● Not available in Analogue mode.

Event recording is a timer programme controlled by information from the TV Guide.

Programme start and end times may be changed by broadcasters and sent to the TV for timer programme to follow the change.

Split Programme is a programme which is interrupted by one or more events.

Both of the above are subject to signals being sent by broadcasters.

### ■ Direct TV Recording ➔ p. 45 and p. 47

You can record the current programme to DVD Recorder / VCR immediately.

#### Note

● Check that the Timer LED (Orange) is lit. If not, timer programmes are not active or not stored.

● "!" will identify any timer events that have been set and overlap. If this occurs then the first event will start and finish as programmed. The next timer event can then start.

● 2 mins. before the starting time: a reminder message appears.

(To remove the message ➔ ; To cancel the programming ➔

● A Timer Programming event will automatically change to the desired programme 10 seconds before the start time.

● To stop Timer Programming event directly prior to the start time, it is necessary to stop the recorder manually.

● Timer Programming will be performed even if the TV is in Pause Live TV recording (p. 47). In this case, Pause Live TV recording will be cancelled.

# Viewing from SD Card

**Photo View:** Still images recorded by digital cameras will be displayed.

**Movie View:** Moving pictures recorded by digital video cameras will be played back.



**1** Insert the SD Card

**2** Select "Photo View" or "Movie View"

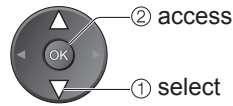
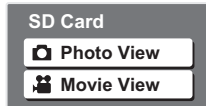

**3** Select the file to be viewed



## Photo View

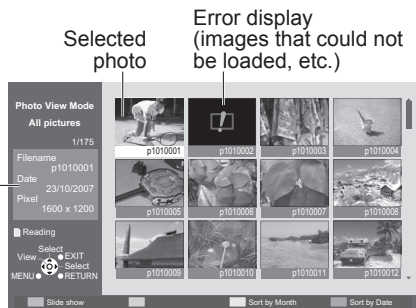

Selected photo information is displayed (Thumbnail)

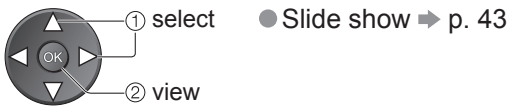

### To sort by date or month recorded

(Sort by Month / Sort by Date)

Display the thumbnail grouped by the same date or the same month

(Sort by Month)

(Sort by Date)

● The group of the photos without record of the date is shown as "Unknown".

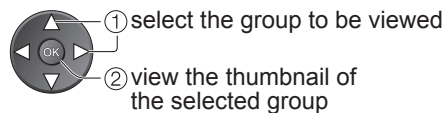

## View

Displayed one at a time

● To display / hide the operation guide

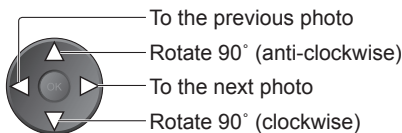

● To return to thumbnail



## Movie View

File format:

Only AVCHD or MPEG2 are supported. Selected movie

● For details → p. 53

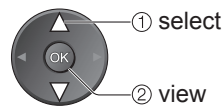
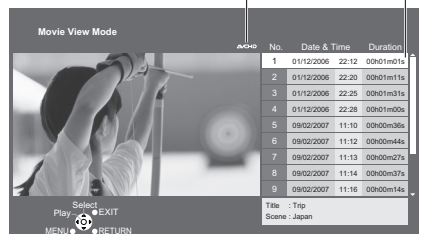

## View

Playback will start

● To display the operation guide



● To hide the operation guide →

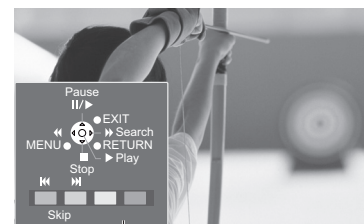

Operation guide

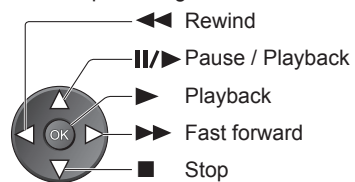

● To the previous movie →

● To the next movie →

● To return to list →

● To display information banner →

● To change aspect ratio (only for the 4:3 movie content) →

## To return to TV

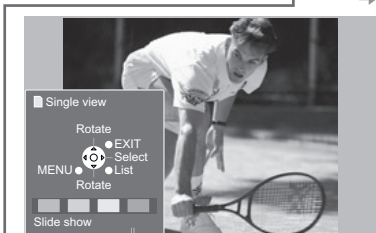

Operation guide

# (Photos and Movies)

## SD Card

- For details on SD Cards → p. 53

■ **To insert**

Label surface → Push until a click is heard

■ **To remove**

Press the centre of the card

**Note**

- Blue LED lights while SD Card is inserted if set "SD Card LED" to "On" in Setup Menu (p. 27).

Blue LED

- During the operation, no signals are output from any of the AV terminals. But the sound in Movie View can be output from AUDIO OUT and DIGITAL AUDIO OUT terminals.
- "Date" shows the date on which the recording was made by the digital camera or digital video camera. The file without record of the date is shown "\*\*\*/\*\*/\*\*\*\*".

## Slide show (Photo View)

### ■ Start Slide show (operate in step ③)

① Select the photo for the first view



② Start Slide show



● To pause →

● To return to Single view →

#### Note

- A Slide show will be completed within the group from which it was started.

### ■ Slide show settings (operate in step ③)

① Display the menu



② Select "Viewing Setup"



② access  
① select

③ Select the items and set

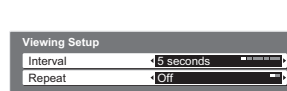

② set  
① select

● "Picture Menu" → p. 26

Menu	Item	Adjustments / Configurations (alternatives)
Viewing Setup	Interval	Select slide show interval (5 / 10 / 15 / 30 / 60 / 90 / 120 seconds)
	Repeat	Slide show repeat (Off / On)

## Audio Settings (Movie View)

You can enjoy the multi-channel sound via an amplifier connected to DIGITAL AUDIO OUT terminal.

### ■ To confirm or change the current sound status (while viewing movies)

① Display the Option menu

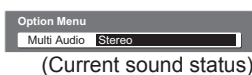

② Change the sound (if the movie has multiple audio signals)

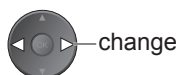

- It may take several seconds to change the sound.

### ■ Audio output settings (operate in step ③)

① Display the menu



② Select "Sound"

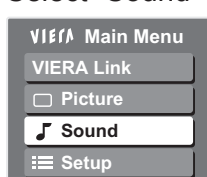

② access  
① select

③ Select "SPDIF Selection" and set

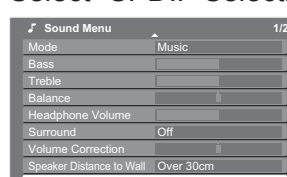

② set  
① select

● Other items → p. 26 and p. 27

Menu	Item	Adjustments / Configurations (alternatives)
Sound	SPDIF Selection	SPDIF : A standard audio transfer file format Selects the initial setting for digital audio output signal from DIGITAL AUDIO OUT terminal (Auto / PCM) Auto: Dolby Digital is output as Dolby Digital Bitstream. MPEG is output as PCM. PCM: Digital output signal is fixed to PCM.

● Viewing from SD Card (Photos and Movies)

Advanced

# Link Functions (Q-Link VIERA Link)

Q-Link connects the TV and DVD Recorder / VCR, and enables easy recording, playback, etc. (p. 45)  
 VIERA Link (HDAVI Control™) connects the TV and the equipment with VIERA Link function, and enables easy control, convenient recording, playback, etc. (p. 46 - 49)  
 You can use Q-Link and VIERA Link functions together.

## Summary of Q-Link and VIERA Link functions

Features	Connection	Q-Link (SCART connection)	VIERA Link (HDMI connection only)	VIERA Link (SCART and HDMI connection)
Analogue programme download		○	—	○
Easy playback***		○	○	○
Power on link***		○	○	○
Power off link***		○	○	○
Speaker control***		—	○	○
Control the menu of the connected equipment by VIERA remote control		—	○*	○*
Direct TV Recording		○	—	○**
Pause Live TV programme		—	—	○**

\* : Available with the equipment which has “HDAVI Control 2” or “HDAVI Control 3” function.

\*\* : Available with the equipment which has “HDAVI Control 3” function.

\*\*\* : These features may be available even with other manufacturers’ equipment supporting HDMI CEC.

## Connections

Read the manual of the equipment, too.

### Q-Link

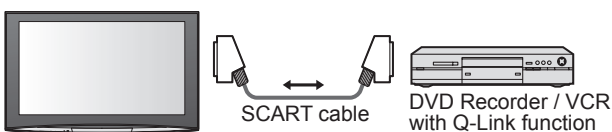

- Connect the DVD Recorder / VCR supporting Q-Link to the TV’s AV1 or AV2 terminal via a fully wired SCART cable.

### VIERA Link

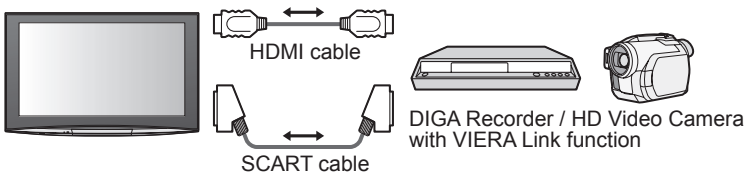

- Connect the equipment supporting VIERA Link to the TV’s AV1, AV2, HDMI1, HDMI2, HDMI3 or HDMI4 terminals via fully wired SCART and HDMI cables together.
- Some functions are available only with HDMI cable connection. But use both HDMI and SCART cables to support many features normally.

- SCART cable  
Use fully wired SCART cable.
- HDMI cable  
Use fully wired HDMI compliant cable. Non-HDMI-compliant cables cannot be utilized.  
Recommended Panasonic’s HDMI cable part number:  
 • RP-CDHG10 (1.0 m)  
 • RP-CDHG15 (1.5 m)  
 • RP-CDHG20 (2.0 m)  
 • RP-CDHG30 (3.0 m)  
 • RP-CDHG50 (5.0 m)

### For Speaker control (Home Cinema)

- To use Amplifier

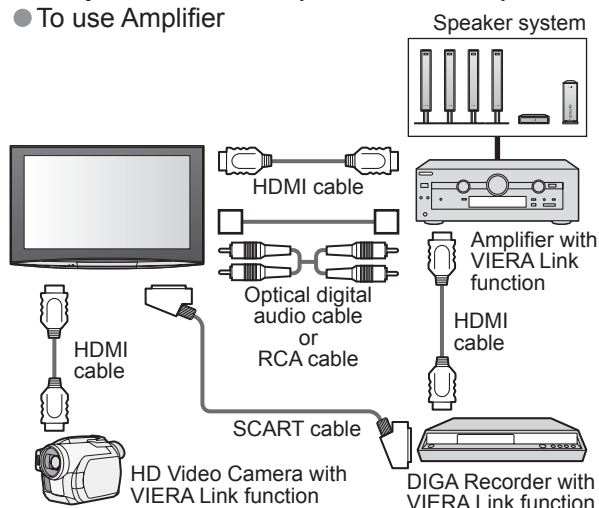

- To use Player theatre

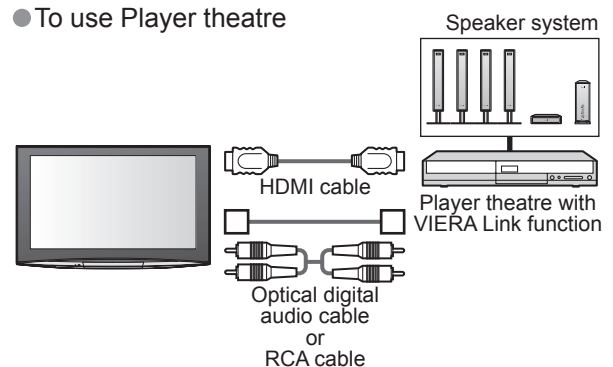

## Q-Link

### ■ Preparations

- Connect the DVD Recorder / VCR with the following logos: "Q-Link", "NEXTVIEWLINK", "DATA LOGIC", "Easy Link", "Megalogic" or "SMARTLINK"
- Q-Link connection → p. 44
- Set up the DVD Recorder / VCR. Read the manual of the equipment.
- Q-Link terminal setup in Setup Menu → "Q-Link" (p. 27), "AV1 / AV2 out" (p. 27)
- Download Analogue programme setting → "Q-Link Download" (p. 27) or "Auto Setup" in Analogue mode (p. 35) or "Auto Setup" - when first using the TV (p. 12)

### ■ Features available

Some recorders are not applicable. Read the manual of the recorder.

Recording the current programme in DVD Recorder / VCR immediately.

Direct TV Recording -  
What you see is What you record

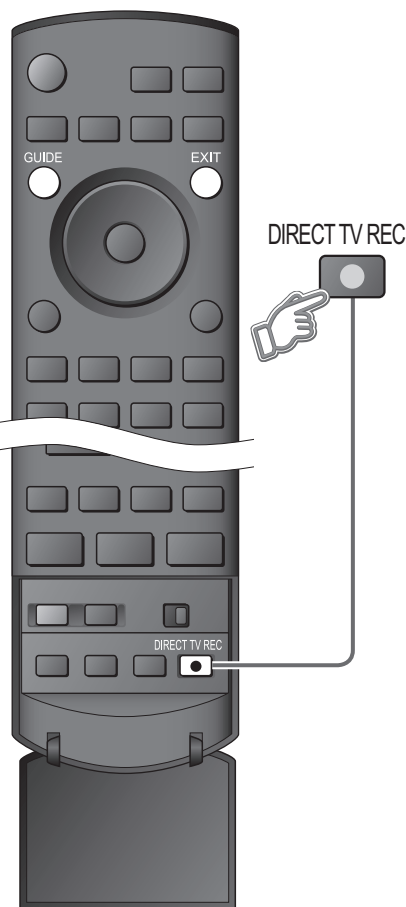

- Available conditions:

Current mode	Using tuner	How to record
Analogue	TV	TV monitor out
	Recorder	Recorder's tuner
DVB	TV	TV monitor out
AV (watching recorder's tuner)	Recorder	Recorder's tuner
AV (watching recorder's external input)	—	Recorder's external input
AV (watching TV's external input)	—	TV monitor out

- When Direct TV Recording is performed, the recorder is automatically turned on if it is in Standby mode.
- Changing programme or turning off the TV is available while the recorder is recording from its own tuner.
- Changing programme is not available while the recorder is recording from the TV tuner.
- Turning off the TV will stop the recording if the recording from an AV source connected to the TV.

### ■ To stop recording

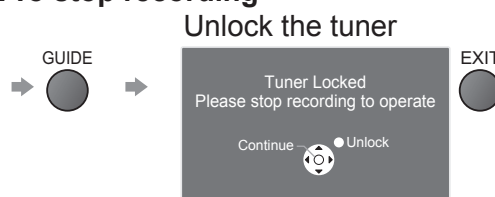

Information / Message

Recording information or if recording is not possible, a message is displayed.

Power on link and Easy playback

When DVD Recorder / VCR starts playback or direct navigator / function menu for the equipment are activated, the TV is turned on and input mode is switched automatically so that you can view the content. (Only when TV is in Standby mode.)

Power off link

When TV is set to Standby mode, the recorder is also automatically set to Standby. (Only when the videocassette or DVD is not active.)

- This function will work even if the TV enters standby mode automatically by Off Timer function or auto power standby function.

● Link Functions  
(Q-Link / VIERA Link)

Advanced

● "DATA LOGIC" (a trademark of Metz Corporation)  
● "Easy Link" (a trademark of Philips Corporation)

● "Megalogic" (a trademark of Grundig Corporation)  
● "SMARTLINK" (a trademark of Sony Corporation)

# Link Functions (Q-Link VIERA Link)

## VIERA Link “HDAVI Control™”\*

\*Enjoy additional HDMI Inter-Operability with Panasonic products which have “HDAVI Control” function. This TV supports “HDAVI Control 3” function.

Connections to the equipment (DIGA Recorder, HD Video Camera, Player theatre, Amplifier, etc.) with HDMI and SCART cables allow you to interface them automatically.

These features are limited to models incorporating “HDAVI Control” and “VIERA Link”.

- Some functions are not available depending on the equipment’s version of HDAVI Control. Please confirm the connected equipment’s version of HDAVI Control.
- VIERA Link “HDAVI Control”, based on the control functions provided by HDMI which is an industry standard known as HDMI CEC (Consumer Electronics Control), is a unique function that we have developed and added. As such, its operation with other manufacturers’ equipment that supports HDMI CEC cannot be guaranteed.

Please refer to individual manuals for other manufacturers’ equipment supporting VIERA Link function. About applicable Panasonic equipment, consult your local Panasonic dealer or refer to the URL: [www.panasonic.co.uk](http://www.panasonic.co.uk)

### ■ Preparations

- Connect the equipment supporting VIERA Link.
  - VIERA Link connection ➔ p. 44
  - Set up the connected equipment. Read the manual of the equipment.
  - For optimal recording, the settings of the recorder might be required. For details, read the manual of the recorder.
  - Download Analogue programme setting ➔ “Q-Link Download” (p. 27) or “Auto Setup” in Analogue mode (p. 35) or “Auto Setup” - when first using the TV (p. 12)
  - Set VIERA Link On in Setup Menu ➔ “VIERA Link” (p. 27)
  - Set up the TV
    - ➔ **After connection, turn the equipment on and then switch the TV on. Select the input mode to HDMI1, HDMI2, HDMI3 or HDMI4 (p. 22), and make sure that an image is displayed correctly.**
- This setup should be done each time when the following conditions occur:
- for the first time
  - when adding or reconnecting equipment
  - when changing setup

### ■ Features available

<b>Easy playback</b>	Automatic Input switching - When the connected equipment is operated, input mode is switched automatically. When it is stopped operating, input mode is returned.
<b>Power on link</b>	When the connected equipment starts playback or direct navigator / function menu for the equipment are activated, the TV is automatically turned on. (Only when TV is in Standby mode.)
<b>Power off link</b>	When TV is set to Standby mode, the connected equipment is also automatically set to Standby. <ul style="list-style-type: none"> <li>● This function will work even if the TV enters standby mode automatically by Off Timer function or auto power standby function.</li> </ul>

■ Features available (Using VIERA Link Menu)

Direct TV Recording - What you see is What you record (HDAVI Control 3)

Direct TV Rec

Recording the current programme in DIGA Recorder immediately.

- This function is available with DIGA Recorder which has "HDAVI Control 3" function.
- Connect DIGA Recorder with both HDMI and SCART cables to use this function.
- If you cannot operate, check the settings and the equipment → "Preparations" (p. 46)
- Changing programme or turning off the TV is available while the recorder is recording from its own tuner.
- Changing programme is not available while the recorder is recording from the TV tuner.
- Turning off the TV will stop the recording if the recording from an AV source connected to the TV.

① Display "VIERA Link Menu"

② Select "Direct TV Rec" and start recording

VIERA Link Menu

Pause Live TV	
Direct TV Rec	Start
VIERA Link Control	Recorder
Speaker Selection	Home Cinema

① select

② start

● You can also start recording directly → DIRECT TV REC

■ To stop recording

Select "Stop" in "Direct TV Rec" and access

VIERA Link Menu

Pause Live TV	
Direct TV Rec	Stop
VIERA Link Control	Recorder
Speaker Selection	Home Cinema

① select

② stop

● You can also stop recording directly.

GUIDE EXIT

You can pause the live TV programme and resume later.

Live TV programme will be recorded on HDD of the connected DIGA Recorder.

- This function is available with DIGA Recorder which has HDD and "HDAVI Control 3" function.
- Connect DIGA Recorder with both HDMI and SCART cables to use this function.
- If you cannot operate, check the settings and the equipment → "Preparations" (p. 46)

Access and pause the live TV programme

Pause Live TV programme (HDAVI Control 3 and Recorder with HDD)

Pause Live TV

① Display "VIERA Link Menu"

② Select "Pause Live TV" and pause

VIERA Link Menu

Pause Live TV	Access
Direct TV Rec	Start
VIERA Link Control	Recorder
Speaker Selection	Home Cinema

① select

② pause

The TV picture will be paused.

- Live TV programme is recorded on HDD from where it was paused.
- If the paused TV picture disappears after a few minutes → (the paused picture will be restored)
- Follow the operation guide to operate Pause Live TV function.

■ To operate Pause Live TV

search backward

pause

search forward

playback

stop

- Operations may be different depending on the recorder. In this case, follow the operation guide or read the manual of the recorder.
- If you stop playback, the recorded programme will be deleted from HDD.

■ To return to Live TV (stop playback of Pause Live TV / cancel pause)

Select "Yes"

TV → ① select

② stop

Pause Live TV

Stop Pause Live TV?	
Yes	No

● If you stop playback or cancel pause, the recorded programme will be deleted from HDD.

# Link Functions (Q-Link VIERA Link)

## ■ Features available (Using VIERA Link Menu)

You can control some functions of the connected equipment with this TV remote control (point the remote control at the TV's signal receiver).

- This function is available with the equipment which has "HDAVI Control 2" or "HDAVI Control 3" function.
- If you cannot operate, check the settings and the equipment → "Preparations" (p. 46)

### Access and operate the menu of the equipment

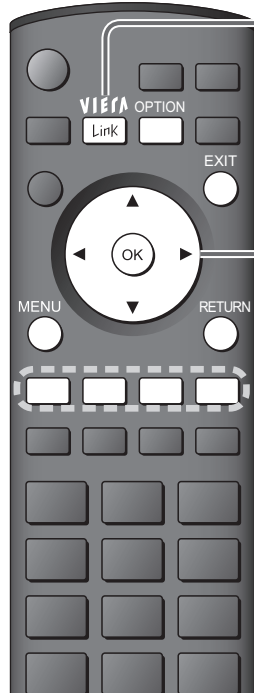

① Display "VIERA Link Menu"



② Select "VIERA Link Control"



③ Select the equipment you want to access

- "Home Cinema" means Player theatre, Recorder theatre and Amplifier.

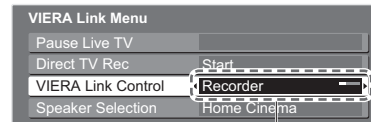

Recorder / Player / Home Cinema / Video Camera

The type of the connected equipment is displayed. Select the type of the equipment and access.

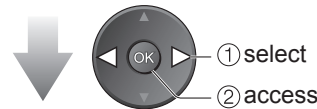

The menu of the accessed equipment (Input mode will be changed automatically)

④ Operate the menu of the equipment

- Available VIERA remote control buttons (depending on the connected equipment):

	Move the cursor / select the menu
	Move the cursor / access / adjust
	Store / set / access
	Return to the previous menu
	Exit the menu
	Display the operation guide for the equipment / The same functions with the OPTION button of the equipment
	Access when the key words are displayed on colour bar

- About the operations for the equipment, read the manual of the equipment.

Control the menu of the connected equipment by VIERA remote control

(HDAVI Control 2)  
(HDAVI Control 3)

**VIERA Link Control**

### ■ If you access the invalid equipment

When the equipment with "HDAVI Control" function is connected

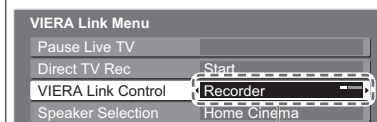

Recorder / Player / Home Cinema / Video Camera

The type of the connected equipment is displayed. But you cannot access it. Use its own remote control to operate the equipment.

When the equipment of other types or manufacturers is connected

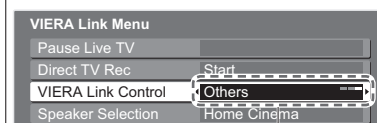

Others

"Others" is displayed. You cannot access it. Use its own remote control to operate the equipment.

## ■ Features available (Using VIERA Link Menu)

You can control the theatre speaker with this TV remote control (point the remote control at the TV's signal receiver).

- This function is available with the Amplifier or Player theatre which has "HDAVI Control" function.
- If you cannot operate, check the settings and the equipment → "Preparations" (p. 46)

### Access and control the speaker volume

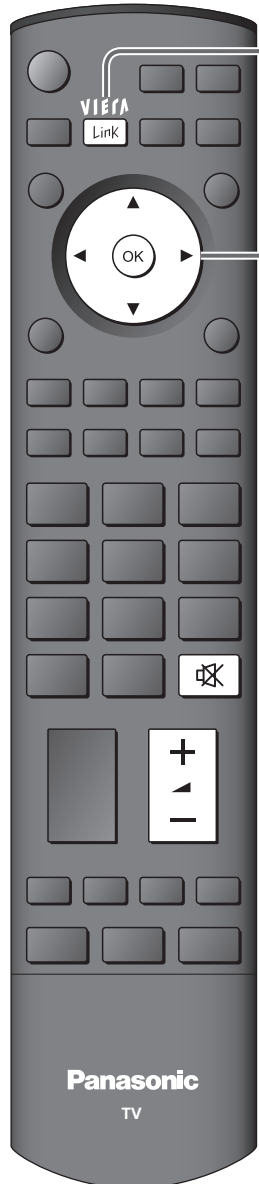

① **Display "VIERA Link Menu"**



② **Select "Speaker Selection"**

③ **Set to "Home Cinema" or "TV"**

**VIERA Link Menu**

Pause Live TV	
Direct TV Rec	Start
VIERA Link Control	Recorder
Speaker Selection	Home Cinema

**Home Cinema**  
Amplifier or Player theatre will be automatically turned on if it is in Standby mode and the sound is from theatre speakers connected to the equipment.

- Volume up / down → 
- Mute → 
- The sound of TV speakers is mute.
- When the equipment is turned off, TV speakers will be active.

**TV**  
TV speakers are active.

Speaker control

Speaker Selection

● Link Functions (Q-Link / VIERA Link)

Advanced

### Note

- This function may not work properly depending on the connected equipment.
- Image or sound may not be available for the first few seconds when the playback starts.
- Image or sound may not be available for the first few seconds when Input mode is switched.
- Volume function will be displayed when adjusting the volume of the equipment.
- Easy playback is also available by using the remote control for Amplifier or Player theatre. Read the manual of the equipment.
- About HDMI cable for connecting Panasonic HD Video Camera, read the manual of the equipment.
- If more than one equipment of the same type are connected to the TV by HDMI cables, for example two DIGA Recorders to HDMI1 and HDMI2, VIERA Link will only be available for the lower terminal number, in this case HDMI1.
- "HDAVI Control 3" is the newest standard (current as of December, 2007) for HDAVI Control compatible equipment. This standard is compatible with conventional HDAVI equipment.
- To confirm this TV's version of HDAVI Control → "System Information" (p. 27)

# External Equipment

These diagrams show our recommendations for connection of your TV to various pieces of equipment. For other connections, consult the instructions for each piece of equipment, the table below, and the specifications (p. 59).

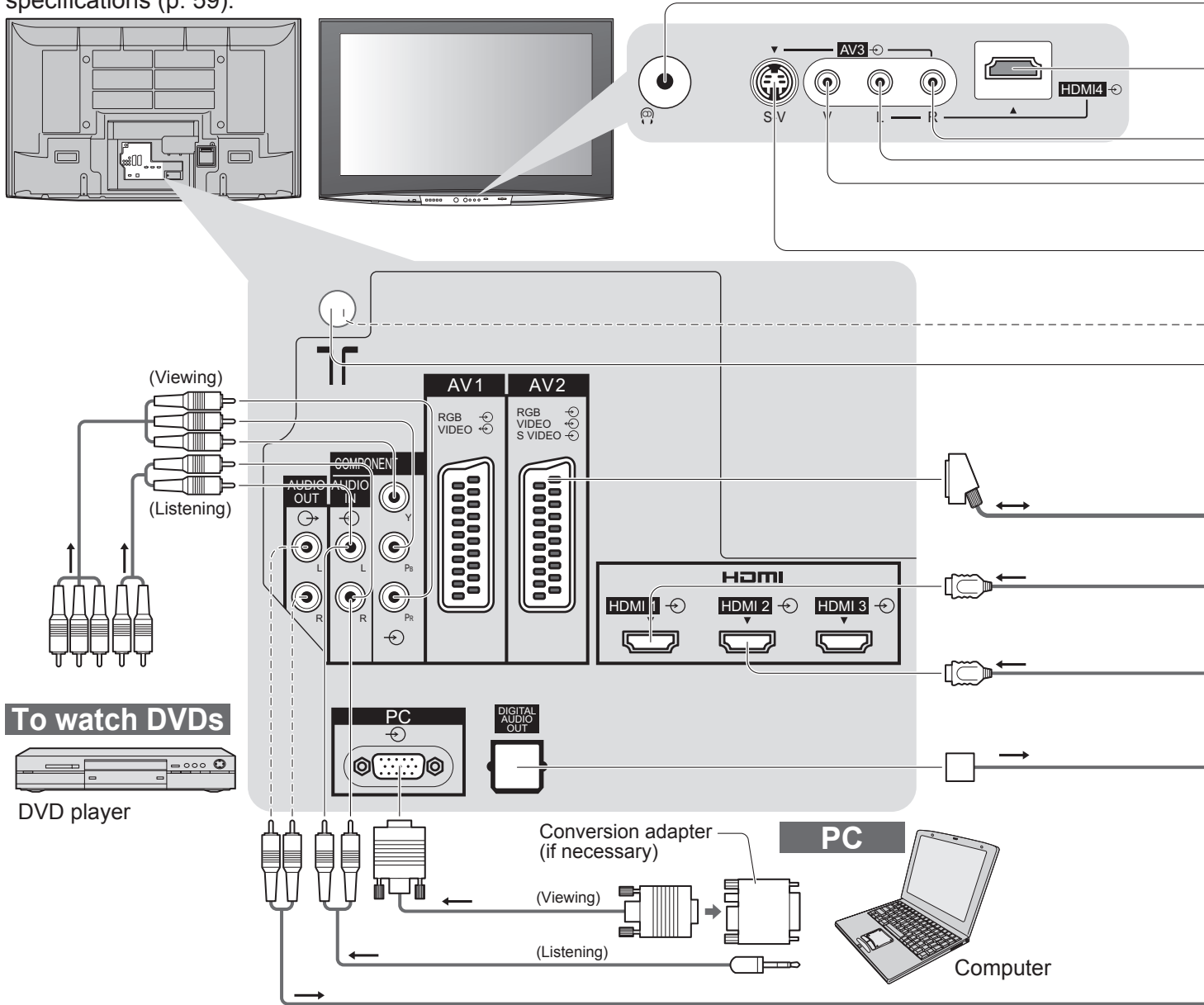

## Types of connectable equipment to each terminal

Terminal	AV1	AV2	AV3 (Front of TV)	
Recording / Playback (equipment)				
To record / playback videocassettes / DVDs (VCR / DVD recorder)	○	○		
To watch DVDs (DVD player)	○	○	○	
To watch camcorder images (Video camera)	○	○	○	
To watch satellite broadcasts (Set top box)	○	○	○	
To play games (Game equipment)	○	○	○	
To use amplifier with speaker system				
Q-Link	○	○		
VIERA Link	○ (with HDMI)	○ (with HDMI)		
Direct TV Recording	○	○		

○: Recommended Connection

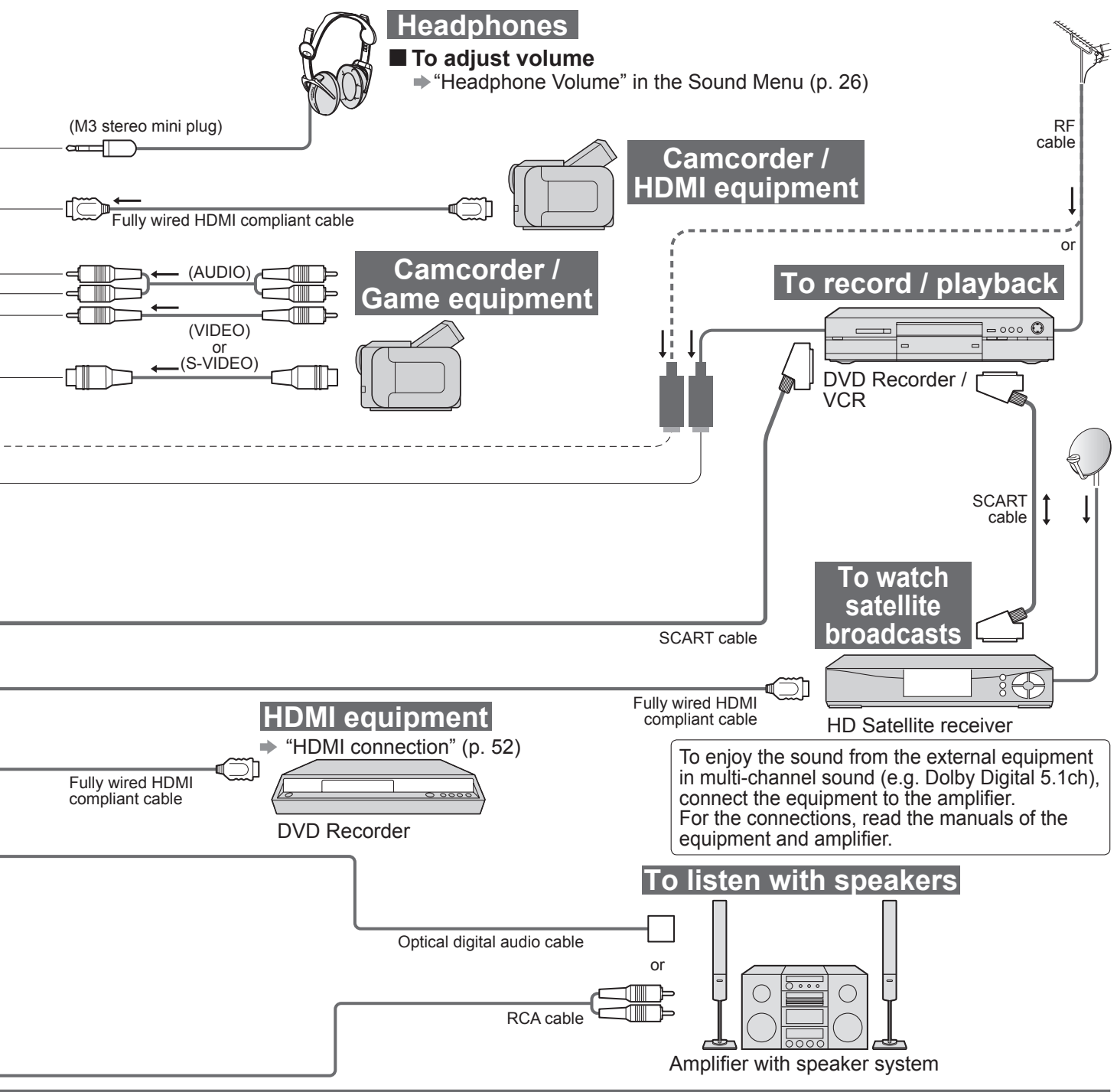

COMPONENT	AUDIO OUT	DIGITAL AUDIO OUT	HDMI			
			1	2	3	4
			<input type="checkbox"/>	<input type="checkbox"/>	<input type="checkbox"/>	<input type="checkbox"/>
<input type="checkbox"/>	<input type="checkbox"/>	<input type="checkbox"/>	<input type="checkbox"/>	<input type="checkbox"/>	<input type="checkbox"/>	<input type="checkbox"/>
<input type="checkbox"/>	<input type="checkbox"/>	<input type="checkbox"/>	<input type="checkbox"/>	<input type="checkbox"/>	<input type="checkbox"/>	<input type="checkbox"/>
<input type="checkbox"/>	<input type="checkbox"/>	<input type="checkbox"/>	<input type="checkbox"/>	<input type="checkbox"/>	<input type="checkbox"/>	<input type="checkbox"/>
<input type="checkbox"/>	<input type="checkbox"/>	<input type="checkbox"/>	<input type="checkbox"/>	<input type="checkbox"/>	<input type="checkbox"/>	<input type="checkbox"/>
<input type="checkbox"/>	<input type="checkbox"/>	<input type="checkbox"/>	<input type="checkbox"/>	<input type="checkbox"/>	<input type="checkbox"/>	<input type="checkbox"/>

# Technical Information

## Auto Aspect

The optimum size and aspect can be chosen, and you can enjoy finer images. (p. 16)

### ■ Auto

Auto aspect determines the best aspect ratio to use to fill your screen. It does this using a four step process to determine if the picture being viewed is a widescreen picture.

If Auto aspect detects a widescreen signal it switches into the appropriate 16:9 or 14:9 widescreen mode. If Auto aspect does not detect a widescreen signal then this advanced TV enhances the picture for optimum viewing pleasure.

The text shown on the screen indicates how Auto aspect determined which ratio to use:

“WIDE” appears in the top left of the screen if a widescreen identification signal (WSS) is found or a signal found through a SCART or HDMI terminal. Auto aspect switches to the appropriate 16:9 or 14:9 widescreen ratio. This function will also work in any aspect mode. “Auto” appears in the top left of the screen if black stripes above and below the picture are detected. Auto aspect chooses the best ratio and expands the picture to fill the screen.

This process can take several minutes, depending on the darkness of the picture.

Signal name	Aspect Control Signal										
	Widescreen signal (WSS)				Control signal through SCART (pin 8) or HDMI terminal						
	TV	AV1	AV2	AV3	COMPONENT	AV1	AV2	HDMI1	HDMI2	HDMI3	HDMI4
PAL	○	○	○	○	/	○	○	/	/	/	/
PAL 525/60	-	-	-	-		○	○				
DVB	○	-	-	-		-	-				
M.NTSC	-	-	-	-		○	○				
NTSC (AV input only)	-	-	-	-		○	○				
SD	525(480)/60i	/	/	/	-	/	/	○	○	○	○
	525(480)/60p				-			○	○	○	○
	625(576)/50i				○			○	○	○	○
	625(576)/50p				○			○	○	○	○
HD	750(720)/50p	/	/	/	-	/	/	○	○	○	○
	750(720)/60p				-			○	○	○	○
	1125(1080)/50i				-			○	○	○	○
	1125(1080)/60i				-			○	○	○	○
	1125(1080)/50p				-			○	○	○	○
	1125(1080)/60p				-			○	○	○	○
	1125(1080)/24p				-			○	○	○	○

### Note

- The ratio varies depending on the programme, etc. If the ratio is greater than the standard “16:9”, black bands may appear at the top and bottom of the screen.
- If the screen size looks unusual when a widescreen-recorded programme is played back on a VCR, adjust the tracking of the VCR. (See the VCR manual.)

## HDMI connection

HDMI (high-definition multimedia interface) allows you to enjoy high-definition digital images and high-quality sound by connecting the TV and the equipment.

HDMI-compatible equipment (\*1) with an HDMI or DVI output terminal, such as a DVD player, a set top box or a game equipment, can be connected to the HDMI terminal using an HDMI compliant (fully wired) cable.

About connections, see “External Equipment” (p. 50).

### Note

- HDMI is the world’s first complete digital consumer AV interface complying with a non-compression standard.
- If the external equipment has only a DVI output, connect to the HDMI1 / 4 terminal via a DVI to HDMI adapter cable (\*2).
- When the DVI to HDMI adapter cable is used, connect the audio cable to the audio input terminal (HDMI1: use COMPONENT-AUDIO terminals / HDMI4: use AV3 audio terminals).
- Audio settings can be made on the “HDMI1 / 4 Input” menu screen. (p. 26)
- Applicable audio signal sampling frequencies (2ch L.PCM): 48 kHz, 44.1 kHz, 32 kHz
- HDMI2 and HDMI3 terminals are for digital audio signal only.
- Use with a PC is not assumed.
- If the connected equipment has an aspect adjustment function, set the aspect ratio to “16:9”.
- These HDMI connectors are “type A”.
- These HDMI connectors are compatible with HDCP (High-Bandwidth Digital Content Protection) copyright protection.
- An equipment having no digital output terminal may be connected to the input terminal of either “COMPONENT”, “S-VIDEO”, or “VIDEO” to receive analogue signals.
- The HDMI input terminal can be used with only the following image signals: 480i, 480p, 576i, 576p, 720p, 1080i and 1080p. Match the output setting of the digital equipment.
- For details of the applicable HDMI signals, see p. 54.
- This TV incorporates HDMI™ (Version 1.3 with Deep Colour, x.v.Color™) technology.

(\*1): The HDMI logo is displayed on HDMI-compliant equipment.  
 (\*2): Enquire at your local digital equipment retailer shop.

## Updating the DVB software

From time to time, a new version of software for DVB mode may become available for download to enhance the performance or operations of the TV.

A notification banner will appear when you tune to one of the BBC channels, or you can search for a new version software by using the "System Update Search Now" function (p. 31).

To start downloading press "OK", this may take up to 20 minutes to complete.

To ignore the new software press "EXIT", but this banner will keep appearing during the period of new software availability, usually 2 to 3 days.

To download any new software automatically, ensure that the "Auto Update Search in Standby" function in the System Update menu is set to "On" (p. 31).

The TV will then download new software automatically at night if it is left in standby without any timer programme in progress.

- During software download and update, DO NOT switch off the TV.

New version 1.00 found.  
Do you really want to update the software and reboot the system?  
Press OK to download the new version  
Press EXIT to ignore

## SD Card

### ■ Cautions in handling SD Card

- Do not remove the card while the TV is accessing data (this can damage card or TV).
- Do not touch the pins on the back of the card.
- Do not subject the card to a high pressure or impact.
- Insert the card in the correct direction (otherwise, card may be damaged).
- Electrical interference, static electricity, or erroneous operation may damage the data or card.
- Back up the recorded data at regular intervals in case of deteriorated or damaged data or erratic operation of the TV. (Panasonic is not liable for any deterioration or damage of recorded data.)

### ■ Data format for Card browsing

Photo : Still images recorded with digital still cameras compatible with JPEG files of DCF\* and EXIF standards

Data format - Baseline JPEG (Sub-sampling 4:4:4, 4:2:2 or 4:2:0)

Max. number of files - 9,999

Image resolution - 160 × 120 to 10,000,000

Movie : SD-Video Standard Ver. 1.2 [MPEG-2 (PS format)] and AVCHD Standard compatible files with an audio format that is either MPEG-1/Layer-2 format or Dolby Digital format

(A modified data with a PC may not be displayed correctly.)

- Compliant card type (maximum capacity): SDHC Card (32 GB), SD Card (2 GB), Multi Media Card (128 MB), miniSD Card (2 GB) (requiring miniSD adapter)
- If miniSD Card is used, insert / remove it together with the adapter.
- Check the latest information on the card type at the following website. (English only)

<http://panasonic.co.jp/pavc/global/cs/>

\*DCF (Design rule for camera file system): Unified standard established by Japan Electronics and Information Technology Industries Association (JEITA).

### Note

- Format the card with the recording equipment.
- The picture may not appear correctly on this TV depending on the recording equipment used.
- Display may take some time when there are many files and folders.
- This function cannot display Motion JPEG and still image not DCF formatted (i.e. TIFF, BMP).
- A data modified with a PC may not be displayed.
- Images imported from a PC must be compatible with EXIF (Exchangeable Image File) 2.0, 2.1, and 2.2.
- Partly degraded files might be displayed at a reduced resolution.
- All ".JPG" extension datas in the card will be read in Photo View Mode.
- The folder and file names may be different depending on the digital camera used.
- Do not use two-byte characters or other special codes.
- The card may become unusable with this TV if the file or folder names are changed.

## SCART, S-VIDEO and HDMI terminal information

### ■ AV1 SCART terminal (RGB, VIDEO, Q-Link)

Suitable inputs for AV1 include RGB (Red / Green / Blue).

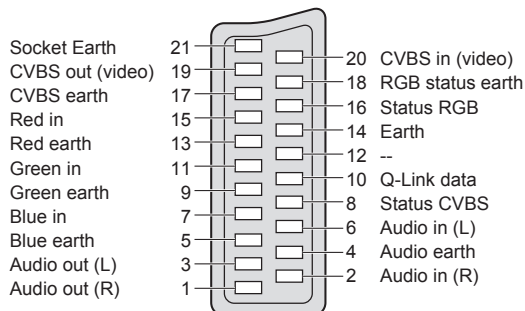

### ■ AV2 SCART terminal (RGB, VIDEO, S-VIDEO, Q-Link)

AV2 - Pins 15 and 20 are dependent on AV2 S-VHS / VIDEO switching.

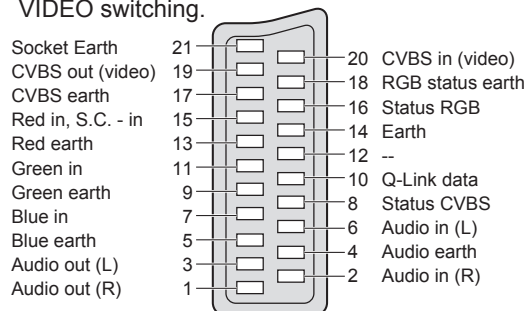

### ■ AV3 S-VIDEO 4 pin terminal



### ■ HDMI terminal

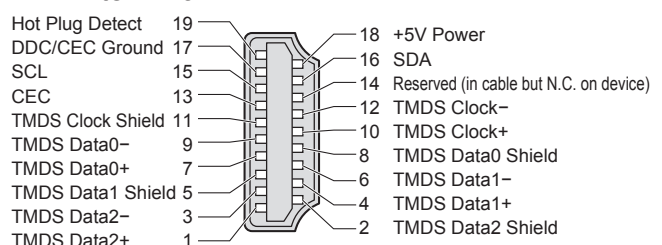

# Technical Information

## PC connection

A PC may be connected to this TV so that the PC screen is displayed and sound is heard from the TV.

- PC signals that can be inputted: Horizontal scanning frequency 31 to 69 kHz; vertical scanning frequency 59 to 86 Hz (more than 1,024 signal lines could result in incorrect display of the image).
- A PC adapter is not necessary for the DOS/V-compliant D-sub 15-pin connector.

### Note

- Some PC models cannot be connected to this TV.
- When using PC, set the colour display quality of PC to the highest position.
- For details of the applicable PC signals, see below.
- Max. display resolution

Aspect	4:3	1,440 × 1,080 pixels
	16:9	1,920 × 1,080 pixels

- D-sub 15-pin connector signal

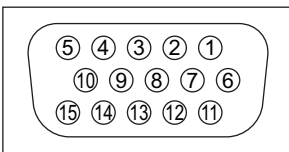

Pin No.	Signal Name	Pin No.	Signal Name	Pin No.	Signal Name
①	R	⑥	GND (Ground)	⑪	NC (not connected)
②	G	⑦	GND (Ground)	⑫	NC (not connected)
③	B	⑧	GND (Ground)	⑬	HD
④	NC (not connected)	⑨	NC (not connected)	⑭	VD
⑤	GND (Ground)	⑩	GND (Ground)	⑮	NC (not connected)

## Input signal that can be displayed

### COMPONENT (Y, P<sub>B</sub>, P<sub>R</sub>), HDMI

\* Mark: Applicable input signal

Signal name	COMPONENT	HDMI
525 (480) / 60i	*	*
525 (480) / 60p	*	*
625 (576) / 50i	*	*
625 (576) / 50p	*	*
750 (720) / 60p	*	*
750 (720) / 50p	*	*
1,125 (1,080) / 60i	*	*
1,125 (1,080) / 50i	*	*
1,125 (1,080) / 60p		*
1,125 (1,080) / 50p		*
1,125 (1,080) / 24p		*

### PC (D-sub 15P)

Signal name	Horizontal frequency (kHz)	Vertical frequency (Hz)
640 × 400 @70 Hz	31.47	70.07
640 × 480 @60 Hz	31.47	59.94
640 × 480 @75 Hz	37.50	75.00
800 × 600 @60 Hz	37.88	60.32
800 × 600 @75 Hz	46.88	75.00
800 × 600 @85 Hz	53.67	85.06
852 × 480 @60 Hz	31.44	59.89
1,024 × 768 @60 Hz	48.36	60.00
1,024 × 768 @70 Hz	56.48	70.07
1,024 × 768 @75 Hz	60.02	75.03
1,024 × 768 @85 Hz	68.68	85.00
1,280 × 1,024 @60 Hz	63.98	60.02
1,366 × 768 @60 Hz	48.39	60.04
Macintosh13" (640 × 480)	35.00	66.67
Macintosh16" (832 × 624)	49.73	74.55
Macintosh21" (1,152 × 870)	68.68	75.06

### Note

- Signals other than above may not be displayed properly.
- The above signals are reformatted for optimal viewing on your display.
- Applicable input signal for PC is basically compatible to VESA standard timing.
- PC signal is magnified or compressed for display, so that it may not be possible to show fine detail with sufficient clarity.

# FAQs

Before requesting service or assistance, please follow these simple guides to resolve the problem. If the problem still persists, please contact your local Panasonic dealer or Panasonic Customer Care Centre for assistance. For details (p. 60)

## White spots or shadow images (noise)

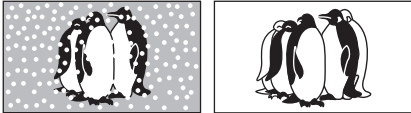

- Check the position, direction, and connection of the aerial.

## Neither image nor sound is produced

- Is the TV in "AV mode"?
- Is the mains lead plugged into the socket outlet?
- Is the TV turned On?
- Check Picture Menu (p. 26) and volume.
- Check all required SCART cables and connections are firmly in place.

## Auto aspect

- Auto aspect is designed to provide you with the best aspect ratio to use to fill your screen. For user control please see p. 52.

## S-Video / black and white picture

- Using AV button please confirm your selection is S-Video i.e. AV2/S (p. 22).

## No programmes shown on TV Guide

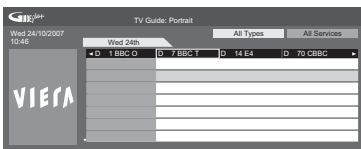

- Check the DVB transmitter.
- Adjust the direction of the aerial to another transmitter installed nearby.
- Check the analogue broadcast. If the image quality is poor, check the aerial and consult your nearest dealer.

## On Screen messages - i.e. EC/AV1

- You can simply clear these →  Press again to redisplay.



## Q-Link function does not work

- Please confirm SCART cable and connection. Also please set "AV1 / AV2 out" in the Setup Menu (p. 27).

## "VIERA Link" function does not work and an error message appears

- Confirm the connection.
- Turn the connected equipment on and then switch the TV on. (p. 46)

## Recording does not start immediately

- Check the settings of the recorder. For details, read the manual of the recorder.

## Permanently lit spots on screen

- Due to production process involved in this technology this may result in some pixels which are permanently lit or unlit. This is not a malfunction.

## Contrast is reduced

- Contrast is lowered in the following conditions without any user operation for a few minutes:
  - no signal in DVB or AV mode
  - selected locked programme
  - selected invalid programme
  - selected radio service
  - displayed menu
  - Digital teletext (no video contents)
  - Thumbnail, list or still picture in SD Card mode

# FAQs

	Problem	Actions
Screen	Chaotic image, noisy	<ul style="list-style-type: none"> <li>● Set "P-NR" in the Picture Menu (to remove noise). (p. 26)</li> <li>● Check nearby electrical products (car, motorcycle, fluorescent lamp).</li> </ul>
	No image can be displayed	<ul style="list-style-type: none"> <li>● Is "Colour" or "Contrast" in the Picture Menu set to the minimum? (p. 26)</li> </ul>
	Blurry or distorted image (no sound or low volume)	<ul style="list-style-type: none"> <li>● Reset programmes. (p. 35)</li> </ul>
	Unusual image is displayed	<ul style="list-style-type: none"> <li>● Turn off the TV with Mains power On / Off switch, then turn it On again.</li> </ul>
Sound	No sound is produced	<ul style="list-style-type: none"> <li>● Is "Sound mute" active? (p. 9)</li> <li>● Is the volume set to the minimum?</li> </ul>
	Sound level is low or sound is distorted	<ul style="list-style-type: none"> <li>● Sound signal reception may be deteriorated.</li> <li>● Set "NICAM" (p. 26) in the Sound Menu to "Off". (Analogue only)</li> </ul>
	Whirring sound is heard	<ul style="list-style-type: none"> <li>● The sound is from built-in cooling fan (not a sign of faulty operation).</li> </ul>
DVB	<ul style="list-style-type: none"> <li>● Due to the digital reception technologies involved, quality of the digital signals may be relatively low in some cases, despite good reception of analogue programmes.</li> </ul>	
	Interference or frozen / disappearing image in DVB	<ul style="list-style-type: none"> <li>● Check "DVB Signal Condition". (p. 35)</li> <li>● If "Signal Quality" or "Signal Strength" are displayed in red, check aerial.</li> <li>● If problem persists, consult your local Panasonic dealer.</li> <li>● Turn the TV off with the Mains power On / Off switch, then turn it On again.</li> </ul>
HDMI	Sound is unusual	<ul style="list-style-type: none"> <li>● Set the sound setting of the connected equipment to "2ch L.PCM".</li> <li>● Check the "HDMI1 / 4 Input" setting in the Sound Menu. (p. 26)</li> <li>● If digital sound connection has a problem, select analogue sound connection. (p. 52)</li> </ul>
	Pictures from external equipment are unusual when the equipment is connected via HDMI	<ul style="list-style-type: none"> <li>● Is the HDMI cable connected properly? (p. 50)</li> <li>● Turn Off the TV and equipment, then turn them On again.</li> <li>● Check an input signal from the equipment. (p. 54)</li> <li>● Use an equipment compliant with EIA/CEA-861/861B.</li> </ul>
Other	TV goes into "Standby mode"	<ul style="list-style-type: none"> <li>● Off Timer function is activated.</li> <li>● The TV enters "Standby mode" about 30 mins. after analogue broadcasting ends.</li> </ul>
	The remote control does not work	<ul style="list-style-type: none"> <li>● Are the batteries installed correctly? (p. 6)</li> <li>● Has the TV been switched On?</li> </ul>
	An error message appears	<ul style="list-style-type: none"> <li>● Follow the message's instructions.</li> <li>● If the problem persists, contact the authorized Service Centre.</li> </ul>

# On screen messages

Message	Meaning / Action
All tuning data will be erased	▶ ● "Shipping Condition" will erase all tuning data (p. 36).
Are you sure ?	▶ ● Confirm correct operation.
Are you sure you want to delete this timer ? Press OK to delete timer Press RETURN to return	▶ ● Confirm correct operation.
Bad Signal	▶ ● The signal is weak. Check the aerial.
Child Lock is active ! Press OK to enter PIN	▶ ● The selected programme is locked in Child Lock (p. 33).
Feature not available	▶ ● It is not possible to record these sources (COMPONENT / HDMI / PC).
Invalid operation - Please check settings and connections	▶ ● Check the Q-Link or VIERA Link connection and setting (p. 44 - 46).
Invalid system time. Please exit !	▶ ● Cannot get the time information. Check the connection of the RF cable.
Key not available	▶ ● You cannot select the same input source between Main and Sub screen when you are viewing in multi window. (p. 16)
Max. number of Timers already set !	▶ ● The maximum number of timer programming events is 15.
New DVB Service Found! Press OK start Auto Setup Press EXIT to Ignore. Selecting Auto Setup will delete current Profile and Childlock settings	▶ ● There is a new DVB service or programme.
New version 1.90 found. Do you really want to update the software and reboot the system ? Press OK to download the new version Press EXIT to Ignore	▶ ● There is a new software available.
No DVB Service found Please check aerial or local DVB service availability. Press OK to start Auto Setup	▶ ● Please follow the message. If it is still failed, consult your local Panasonic dealer.
No module inserted	▶ ● Check the CI module inserted completely (p. 31).
No Recording - Check media	▶ ● The tape or disc may be "write protected", missing or damaged.
No Recording - Already recording	▶ ● The equipment may already be recording.
No Recording - Unknown reason	▶ ● The recording may not be performed. Check the equipment. ● Disc or tape may be full.
No Service	▶ ● The broadcaster has stopped the service.
No Signal	▶ ● Check the connection of the RF cable.
PIN incorrect !	▶ ● The PIN number you entered is wrong.
Please check settings and connections on HDMI devices.	▶ ● Communication error in VIERA Link function (p. 46).
Please wait.	▶ ● A function is in progress.
Recording this service now	▶ ● The recorder is recording the programme signal from its own tuner. You can turn the TV off and leave the equipment recording in the normal way.
Sending Preset Data Please wait !	▶ ● Q-Link or VIERA Link programme download is in progress.
Shipping condition completed. TV can now be switched off.	▶ ● "Auto Setup" will automatically start when Mains power On / Off switch is next turned On. (p. 12)
Software successfully updated Press EXIT to continue	▶ ● The software updating is finished.
Software Update failed. Please try again later. Press EXIT to continue	▶ ● Perform "System Update Search Now" in System Update (p. 31). If this is still unsuccessful, there may not be any new software available.
Timer already expired !	▶ ● Starting time in Timer Programming is already past. Set correctly (p. 41).
Timer Event Due to Start DVB 1: BBC1 has been Programmed for recording at 20:00	▶ ● This message will appear 2 minutes before timer programming event due to start.
Timer incorrect !	▶ ● Set Start and End times in Timer Programming correctly (p. 41).
Tuner Locked Please stop recording to operate	▶ ● If you want to unlock, cancel Direct TV Recording (p. 45 and p. 47) or Timer Programming (p. 40).
Unable to download, Check Equipment	▶ ● The tape or disc is active. Stop the equipment and try again.

# On screen messages

## ■ SD Card

Message	Meaning / Action
Cannot read file	<ul style="list-style-type: none"> <li>● The file is broken or unreadable.</li> <li>● The TV does not support the format. (For the applicable formats and data, see p. 53.)</li> </ul>
Confirm SD card	<ul style="list-style-type: none"> <li>● The inserted SD card has a problem.</li> </ul>
Is SD Card in?	<ul style="list-style-type: none"> <li>● Confirm SD Card is inserted correctly.</li> </ul>
No valid file to play	<ul style="list-style-type: none"> <li>● The card has no data.</li> </ul>
Over 9999 pictures found	<ul style="list-style-type: none"> <li>● Maximum valid number of photos is 9,999.</li> </ul>
This operation is not possible	<ul style="list-style-type: none"> <li>● Your operation is not available.</li> </ul>

# Glossary

## ■ DVB

Digital Video Broadcasting

## ■ DVD

Digital Versatile Disc

## ■ DVI

Digital Visual Interface

## ■ EPG

Electronic Programme Guide

## ■ HDMI

High-Definition Multimedia Interface

## ■ NTSC

National Television System Committee  
One of the television signals used in USA, etc.

## ■ RF

Radio Frequency - Signal received from terrestrial aerial

## ■ RGB / S-Video / Video

Choose between these three video formats depending on personal preference and equipment requirement (RGB - Red, Green and Blue)

## ■ SCART

21 pin connection used for video, audio and switching signals (Also known as Euro SCART and Peritel)

## ■ VCR

Video Cassette Recorder

# Index

<b>A</b> Accessories ..... 6	<b>H</b> HDMI ..... 52-54	<b>R</b> Remote control ..... 6, 9
Add New DVB Services ..... 35	Hold ..... 14, 19	Reset to Default ..... 26
Analogue Manual Tuning ..... 35	Home Cinema ..... 44, 49	RGB ..... 59
Aspect ..... 16, 52	<b>I</b> Information banner ..... 15	<b>S</b> Sales and Support Information ..... 60
Audio Description ..... 15, 26	Input Labels ..... 38	Satellite receiver ..... 11, 22, 50
Auto Setup ..... 12, 35	Input signal ..... 54	SCART ..... 10, 44, 53
AV1 / AV2 out ..... 27, 45	Intelligent Frame Creation ..... 27	SD Card ..... 42, 53
<b>B</b> Banner Display Timeout ..... 27	<b>L</b> Licence ..... 59	SD Card LED ..... 27, 43
<b>C</b> Category list ..... 20	<b>M</b> Mains Lead ..... 10	Shipping Condition ..... 36
Child Lock ..... 33	Mains power On / Off switch ..... 9, 12	Slide show ..... 43
CI module ..... 31	Maintenance ..... 5	Specifications ..... 59
Clamper ..... 8	Menu Functions ..... 24-29	Split Programme ..... 21
COMPONENT ..... 50, 54	Mode ..... 26	SRS TruSurround XT ..... 26
Connection ..... 10, 44, 50	Movie View ..... 42	Subtitles ..... 14, 19
<b>D</b> Digital Cinema Colour ..... 26	Multi Audio ..... 15	Surround ..... 26
Direct TV Recording ..... 45, 47	Multi window ..... 16	S-Video ..... 50, 53
Download to equipment ..... 12, 27	<b>N</b> New Service Message ..... 35	System Update ..... 31, 53
D-sub 15-pin ..... 54	NICAM ..... 26	<b>T</b> Teletext ..... 17-19
DVB Manual Tuning ..... 35	Normalisation ..... 9, 25	Timer LED ..... 9, 21, 41
DVB Profile Edit ..... 32	NTSC ..... 28, 59	Timer Programming ..... 40
DVB Settings ..... 30	<b>O</b> Off Timer ..... 15, 27	Tuning Menu ..... 34
DVB Signal Condition ..... 35	Optional accessories ..... 6	TV Guide ..... 20
DVI ..... 52	Owner ID ..... 12, 37	TV speaker ..... 49
DVDs ..... 10, 22	<b>P</b> PAL ..... 59	Type list ..... 20
<b>E</b> EPG ..... 20	PC ..... 39, 54	<b>U</b> Update the software ..... 31, 53
External equipment ..... 10, 22, 50	Pedestal ..... 7	User input ..... 38
External input ..... 22, 39	Photo View ..... 42	<b>V</b> Video ..... 22, 50
Event recording ..... 21	Picture Overscan ..... 27	VIERA Link ..... 44, 46-49
<b>F</b> FAQs ..... 55, 56	PIN number ..... 12, 33, 37	Viewing Mode ..... 26
Free input menu ..... 25	P-NR ..... 26	Volume Correction ..... 26
<b>G</b> GUIDE Plus+ Settings ..... 27	Power LED ..... 9	<b>W</b> WSS ..... 52
	<b>Q</b> Q-Link ..... 27, 44, 45	<b>Z</b> Zoom ..... 16
	Quick Start Guide ..... 6-13	

# Licence

- DVB is a trademark of the DVB Digital Video Broadcasting Project (1991 to 1996).
- VGA is a trademark of International Business Machines Corporation.
- Macintosh is a registered trademark of Apple Inc., USA.
- S-VGA is a registered trademark of the Video Electronics Standard Association.  
Even if no special notation has been made of company or product trademarks, these trademarks have been fully respected.
- SDHC Logo is a trademark.
- HDMI, the HDMI Logo and High-Definition Multimedia Interface are trademarks or registered trademarks of HDMI Licensing LLC.
- HDAVI Control™ is a trademark of Matsushita Electric Industrial Co., Ltd.
- x.v.Color™ is a trademark.
- “AVCHD” and the “AVCHD” logo are trademarks of Matsushita Electric Industrial Co., Ltd. and Sony Corporation.
- Manufactured under license from Dolby Laboratories.  
Dolby and the double-D symbol are trademarks of Dolby Laboratories.
- TruSurround XT, SRS and (●) symbol are trademarks of SRS Labs, Inc.  
TruSurround XT technology is incorporated under license from SRS Labs, Inc.
- GUIDE Plus+ is (1) a registered trademark or trademark of, (2) manufactured under license from and (3) subject of various international patents and patent applications owned by, or licensed to, Gemstar-TV Guide International, Inc. and/or its related affiliates.

# Specifications

		TH-58PZ800B	TH-65PZ800B	
<b>Power Source</b>		AC 220-240 V, 50 / 60 Hz		
<b>Power Consumption</b>	<b>Average use</b>	635 W	700 W	
	<b>Standby condition</b>	0.4 W (Without monitor out recording) 24 W (With monitor out recording)		
<b>Display panel</b>	<b>Aspect Ratio</b>	16:9		
	<b>Visible screen size</b>	147 cm (diagonal) 1,284 mm (W) × 723 mm (H)	165 cm (diagonal) 1,434 mm (W) × 807 mm (H)	
	<b>Number of pixels</b>	2,073,600 (1,920 (W) × 1,080 (H)) [5,760 × 1,080 dots]		
<b>Sound</b>	<b>Speaker</b>	Woofer (Φ 80 mm) × 2 pcs, Tweeter (23 mm × 100 mm) × 2 pcs		
	<b>Audio Output</b>	31 W (15.5 W + 15.5 W), 10 % THD		
	<b>Headphones</b>	M3 (3.5 mm) stereo mini Jack × 1		
<b>PC signals</b>		VGA, SVGA, XGA SXGA ..... (compressed) Horizontal scanning frequency 31 - 69 kHz Vertical scanning frequency 59 - 86 Hz		
<b>Receiving Systems / Band name</b>		<b>PAL I</b> : UHF E21-68 <b>PAL 525/60</b> : Playback of NTSC tape from some PAL Video recorders (VCR) or NTSC disc playback from DVD player and recorder. <b>DVB</b> : Digital terrestrial services via UHF aerial input. <b>M.NTSC</b> : Playback from M.NTSC Video recorders (VCR). <b>NTSC (AV input only)</b> : Playback from NTSC Video recorders (VCR).		
<b>Aerial input</b>		UHF		
<b>Operating Conditions</b>		<b>Temperature</b> : 0 °C - 35 °C <b>Humidity</b> : 20 % - 80 % RH (non-condensing)		
<b>Connection Terminals</b>	<b>AV1 (Scart terminal)</b>	21 Pin terminal (Audio/Video in, Audio/Video out, RGB in, Q-Link)		
	<b>AV2 (Scart terminal)</b>	21 Pin terminal (Audio/Video in, Audio/Video out, RGB in, S-Video in, Q-Link)		
	<b>AV3</b>	<b>VIDEO</b>	RCA PIN Type × 1	1.0 V[p-p] (75 Ω)
		<b>S-VIDEO</b>	Mini DIN 4-pin	Y:1.0 V[p-p] (75 Ω) C:0.286 V[p-p] (75 Ω)
		<b>AUDIO L - R</b>	RCA PIN Type × 2	0.5 V[rms]
	<b>COMPONENT</b>	<b>VIDEO</b>	<b>Y</b>	1.0 V[p-p] (including synchronization)
		<b>AUDIO L - R</b>	<b>P<sub>B</sub>, P<sub>R</sub></b>	±0.35 V[p-p]
	<b>Others</b>	<b>HDMI1 / 2 / 3 / 4</b>	TYPE A Connectors HDMI™ (Version 1.3 with Deep Colour, x.v.Color™) ● This TV supports “HDAVI Control 3” function.	
		<b>PC</b>	HIGH-DENSITY D-SUB 15PIN	R, G, B/0.7 V[p-p] (75 Ω) HD, VD/TTL Level 2.0 - 5.0 V[p-p] (high impedance)
		<b>Card slot</b>	SD Card slot × 1	
<b>Output</b>		<b>AUDIO L - R</b>	RCA PIN Type × 2	0.5 V[rms] (high impedance)
	<b>DIGITAL AUDIO OUT</b>	PCM / Dolby Digital, Fiber optic		
<b>Dimensions ( W × H × D )</b>		1,445 mm × 949 mm × 409 mm (With Pedestal) 1,445 mm × 898 mm × 109 mm (TV only)	1,599 mm × 993 mm × 109 mm	
<b>Mass</b>		63.5 kg Net (With Pedestal) 59.0 kg Net (TV only)	73.0 kg Net	

## Note

- Design and Specifications are subject to change without notice. Mass and Dimensions shown are approximate.
- This equipment complies with the EMC standards listed below.  
EN55013, EN61000-3-2, EN61000-3-3, EN55020, EN55022, EN55024.
- Pedestal: ST-58R4-WL (For safety approval)

## Information for Users on Collection and Disposal of Old Equipment and used Batteries



These symbols on the products, packaging, and/or accompanying documents mean that used electrical and electronic products and batteries should not be mixed with general household waste. For proper treatment, recovery and recycling of old products and used batteries, please take them to applicable collection points, in accordance with your national legislation and the Directives 2002/96/EC and 2006/66/EC.

By disposing of these products and batteries correctly, you will help to save valuable resources and prevent any potential negative effects on human health and the environment which could otherwise arise from inappropriate waste handling.

For more information about collection and recycling of old products and batteries, please contact your local municipality, your waste disposal service or the point of sale where you purchased the items. Penalties may be applicable for incorrect disposal of this waste, in accordance with national legislation.



### For business users in the European Union

If you wish to discard electrical and electronic equipment, please contact your dealer or supplier for further information.



### [Information on Disposal in other Countries outside the European Union]

These symbols are only valid in the European Union. If you wish to discard these items, please contact your local authorities or dealer and ask for the correct method of disposal.

### Note for the battery symbol (bottom two symbol examples):

This symbol might be used in combination with a chemical symbol. In this case it complies with the requirement set by the Directive for the chemical involved.

Cd

## Sales and Support Information

### Customer Care Centre

- For customers within the UK: **0844 844 3852**
- For customers within the Republic of Ireland: **01 289 8333**
- Visit our website for product information [www.panasonic.co.uk](http://www.panasonic.co.uk)
- E-mail: [customer.care@panasonic.co.uk](mailto:customer.care@panasonic.co.uk)

### Direct Sales at Panasonic UK

- For customers: **0844 844 3856**
- Order accessory and consumable items for your product with ease and confidence by phoning our Customer Care Centre Monday – Thursday 9:00am – 5:30pm, Friday 9:30am – 5:30pm (Excluding public holidays).
- Or go on line through our Internet Accessory ordering application at [www.panasonic.co.uk](http://www.panasonic.co.uk).
- Most major credit and debit cards accepted.
- All enquiries transactions and distribution facilities are provided directly by Panasonic UK Ltd.
- It couldn't be simpler!
- Also available through our Internet is direct shopping for a wide range of finished products, take a browse on our website for further details.

*Interested in purchasing an extended guarantee?*

*Please call 0870 240 6284 or visit [www.panasonic.co.uk/guarantee](http://www.panasonic.co.uk/guarantee).*

This product is licensed under the AVC patent portfolio license for the personal and non-commercial use of a consumer to (i) encode video in compliance with the AVC Standard ("AVC Video") and/or (ii) decode AVC Video that was encoded by a consumer engaged in a personal and non-commercial activity and/or was obtained from a video provider licensed to provide AVC Video. No license is granted or shall be implied for any other use. Additional information may be obtained from MPEG LA, LLC. See <http://www.mpegla.com>.

GEMSTAR-TV GUIDE INTERNATIONAL, INC. AND/OR ITS RELATED AFFILIATES ARE NOT IN ANY WAY LIABLE FOR THE ACCURACY OF THE PROGRAM SCHEDULE INFORMATION PROVIDED BY THE GUIDE PLUS+ SYSTEM. IN NO EVENT SHALL GEMSTAR-TV GUIDE INTERNATIONAL, INC. AND/OR ITS RELATED AFFILIATES BE LIABLE FOR ANY AMOUNTS REPRESENTING LOSS OF PROFITS, LOSS OF BUSINESS, OR INDIRECT, SPECIAL, OR CONSEQUENTIAL DAMAGES IN CONNECTION WITH THE PROVISION OR USE OF ANY INFORMATION, EQUIPMENT, OR SERVICES RELATING TO THE GUIDE PLUS+ SYSTEM.

<http://www.europe.guideplus.com/>

### Customer's Record

The model number and serial number of this product may be found on its rear panel. You should note this serial number in the space provided below and retain this book, plus your purchase receipt, as a permanent record of your purchase to aid in identification in the event of theft or loss, and for Warranty Service purposes.

Model Number \_\_\_\_\_

Serial Number \_\_\_\_\_

## Panasonic (U. K.) Ltd.

Willoughby Road, Bracknell, Berks RG12 8FP Web Site : <http://www.panasonic-europe.com>

© 2008 Matsushita Electric Industrial Co., Ltd. All Rights Reserved.

Printed in Czech Republic