

## Operating Instructions

### DVD Recorder

Model No. **DMR-EX773**

# DIGA



### Dear customer

Thank you for purchasing this product. For optimum performance and safety, please read these instructions carefully. Before connecting, operating or adjusting this product, please read the instructions completely. Please keep this manual for future reference.



**HDMI**

**VIERA  
Link**

**DVB**  
Digital Video  
Broadcasting



#### Notice for DVB functions

- DVB and the DVB logos are trademarks of the DVB Project.
- This DVD recorder is for viewing and recording free to view channels only, not pay TV or encrypted channels.

#### About descriptions in these operating instructions

- Pages to be referred to are indicated as "⇒ ○○".

- This unit does not support analogue broadcasts.

#### Region number supported by this unit

Region numbers are allocated to DVD Recorders and DVD-Video according to where they are sold.

- The region number of this unit is "2".
- The unit will play DVD-Video marked with labels containing "2" or "ALL".

Example:



Web Site: <http://www.panasonic-europe.com>

## CAUTION!

THIS PRODUCT UTILIZES A LASER.  
USE OF CONTROLS OR ADJUSTMENTS OR PERFORMANCE OF PROCEDURES OTHER THAN THOSE SPECIFIED HEREIN MAY RESULT IN HAZARDOUS RADIATION EXPOSURE.  
DO NOT OPEN COVERS AND DO NOT REPAIR YOURSELF. REFER SERVICING TO QUALIFIED PERSONNEL.

## WARNING:

TO REDUCE THE RISK OF FIRE, ELECTRIC SHOCK OR PRODUCT DAMAGE,  
● DO NOT EXPOSE THIS APPARATUS TO RAIN, MOISTURE, DRIPPING OR SPLASHING AND THAT NO OBJECTS FILLED WITH LIQUIDS, SUCH AS VASES, SHALL BE PLACED ON THE APPARATUS.  
● USE ONLY THE RECOMMENDED ACCESSORIES.  
● DO NOT REMOVE THE COVER (OR BACK); THERE ARE NO USER SERVICEABLE PARTS INSIDE. REFER SERVICING TO QUALIFIED SERVICE PERSONNEL.

## CAUTION!

● DO NOT INSTALL OR PLACE THIS UNIT IN A BOOKCASE, BUILT-IN CABINET OR IN ANOTHER CONFINED SPACE. ENSURE THE UNIT IS WELL VENTILATED. TO PREVENT RISK OF ELECTRIC SHOCK OR FIRE HAZARD DUE TO OVERHEATING, ENSURE THAT CURTAINS AND ANY OTHER MATERIALS DO NOT OBSTRUCT THE VENTILATION VENTS.  
● DO NOT OBSTRUCT THE UNIT'S VENTILATION OPENINGS WITH NEWSPAPERS, TABLECLOTHS, CURTAINS, AND SIMILAR ITEMS.  
● DO NOT PLACE SOURCES OF NAKED FLAMES, SUCH AS LIGHTED CANDLES, ON THE UNIT.  
● DISPOSE OF BATTERIES IN AN ENVIRONMENTALLY FRIENDLY MANNER.

## CAUTION

Danger of explosion if battery is incorrectly replaced. Replace only with the same or equivalent type recommended by the manufacturer. Dispose of used batteries according to the manufacturer's instructions.

THIS UNIT IS INTENDED FOR USE IN MODERATE CLIMATES.

This product may receive radio interference caused by mobile telephones during use. If such interference is apparent, please increase separation between the product and the mobile telephone.

The socket outlet shall be installed near the equipment and easily accessible.  
The mains plug of the power supply cord shall remain readily operable.  
To completely disconnect this apparatus from the AC Mains, disconnect the power supply cord plug from AC receptacle.



<b>DANGER – VISIBLE AND INVISIBLE LASER RADIATION WHEN OPEN. AVOID DIRECT EXPOSURE TO BEAM.</b> FDA 21 CFR/Class IIb	
<b>CAUTION</b>	CLASS 3B VISIBLE AND INVISIBLE LASER RADIATION WHEN OPEN. AVOID EXPOSURE TO THE BEAM. IEC60825-1 +A2/Class 3B
<b>ATTENTION</b>	RAYONNEMENT LASER VISIBLE ET INVISIBLE. CLASSE 3B. EN CAS D'OUVERTURE, EVITER UNE EXPOSITION AU FAISCEAU.
<b>FORSIGTIG</b>	SYNLIG OG USYNLIG LASERSTRÅLING KLASSE 3B. NÅR LAGET ER ÅBENT, UNDGÅ AT BLIVE UDSAT FOR STRÅLEN.
<b>VARO</b>	AVAITTAESSA OLET ALTIINNA LUOKAN 3B NÄKYVÄÄ JA NÄKYMÄTÖNTÄ LASERSÄTELYÄ. VARO ALITUSTUMISTA SÄTEELLE.
<b>WARNING</b>	KLASS 3B SYNLIG OCH OSYNLIG LASERSTRÅLNING NÄR DENNA DEL ÄR ÖPPNAD. UNDVIK EXPONERING FÖR STRÅLEN.
<b>VORSICHT</b>	SICHTBARE UND UNSICHTBARE LASERSTRAHLUNG KLASSE 3B. WENN ABDECKUNG GEÖFFNET, NICHT DEM STRAHL AUSSETZEN.
<b>注意</b>	一 打开时有可见及不可见激光辐射。避免光束照射。
<b>注意</b>	一 この装置は可視及び不可視レーザー光が出ます。レーザー光を見たり、触れたりしないでください。VQL1J70

(Inside of product)

# Table of contents

<b>Getting started</b>	
Included accessories	4
The remote control information	4
HDD (Hard disk drive) handling care	5
Unit care	5
<b>Quick Start Guide</b>	
Control reference guide	6
Easy access to various functions — FUNCTION MENU	
Display	7
STEP 1 Connection	8
STEP 2 Channel reception settings and TV aspect settings	10
HDD and disc information	11
USB memory information	13
Regarding DivX files, Music files and still pictures (JPEG)	14
Media handling (Disc/USB memory)	15
<b>Basic operations</b>	
Watching Television	16
Playing recorded video contents/Playing play-only discs	17
Recording television programmes	18
Deleting titles	19
<b>Advanced operations</b>	
Notes for recording	20
Advanced recording	21
Recording modes and approximate recording times	21
When the format confirmation screen is displayed	21
When removing a recorded disc	21
Flexible Recording	22
Playing while you are recording	22
Recording broadcasts from external equipment	23
Making timer recordings on the television	23
Recording from digital satellite receiver	23
Linked timer recordings with external equipment (digital satellite receiver) — EXT LINK	23
Timer recording	24
Manually programming timer recordings	24
Check, change or delete a programme	24
To cancel recording when recording has already begun	25
Language for digital broadcast with multi-audio or multi-subtitle	25
Relief Recording	25
Auto Renewal Recording	25
Notes on timer recording	25
Advanced playback	26
Operation during play	26
Changing audio during play	26
Selecting recorded programmes (titles) to play—	
DIRECT NAVIGATOR	27
Switching the DIRECT NAVIGATOR appearance	27
To sort the titles for easy searching	27
To play grouped titles <b>HDD</b>	27
To edit the group of titles <b>HDD</b>	27
Playing DivX, Music files and still pictures (JPEG)	28
Showing the menu screen	28
Playing DivX video contents	28
Playing Music files	29
Playing still pictures	30
Start Slideshow	30
Useful functions during still picture play	31
Playing music	32
To play music CD	32
To play music recorded on HDD	32
Useful functions during music play	32
Convenient functions	33
FUNCTION MENU Display	33
To pause the TV programme you are watching—Pause Live TV	33
Linked operations with the TV (VIERA Link “HDAVI Control™/Q Link)	34
Easy control only with VIERA remote control	35
<b>Editing</b>	
Editing titles/chapters	36
Creating, editing and playing Playlists (Video)	38
Editing still pictures and music	40
Creating, editing and playing Playlists (Picture)	42
Entering text	44

<b>Copying</b>	
Copying titles or Playlists (Video)	45
Copy [Video (HDD to DVD)]	46
Copying using the copying list—Advanced Copy	47
Copying a finalised DVD-R, DVD-R DL, DVD-RW (DVD-Video format), +R and +R DL	48
Copying Video (MPEG2) from a video equipment	49
Copying still pictures/Playlist (Picture)	50
Copying new still pictures on the USB memory—Copy New Pictures	50
Copying using the copying list	50
Copying still pictures on the USB memory	51
Copying music to HDD	52
Copying music from a CD	52
Copying music from a USB memory or CD-R/CD-RW/DVD-R/DVD-R DL	52
<b>Setting menus</b>	
Using on-screen menus/Status message	54
HDD and disc management	56
Common procedures	56
Setting the protection	56
Deleting all titles and Playlists (Video)—Delete all titles	57
Providing a name for a disc	57
Deleting all the contents—Format	57
Selecting the background style—Top Menu	58
Selecting whether to show the Top Menu first—Auto-Play Select	58
Enabling discs to be played on other equipment—Finalise	58
Creating Top Menu—Create Top Menu	58
Changing the unit's settings	59
Common procedures	59
Tuning	59
Disc	61
Picture	61
Sound	62
Display	62
Connection	63
Others	64
Other Settings	66
Child Lock	66
Television operation	66
<b>Reference</b>	
Additional connections	66
Connecting a television with AUDIO/VIDEO	66
Connecting an amplifier with a digital input terminal	67
Connecting a stereo amplifier	67
Connecting a television and VCR or digital satellite receiver	67
Frequently asked questions	68
Messages	69
Troubleshooting guide	71
Specifications	77
Glossary	78
Safety precautions	79
Index	Back Cover

Getting started

Quick Start Guide

Basic operations

Advanced operations

Editing

Copying

Setting menus

Reference

# Included accessories



Please check and identify the supplied accessories.  
(Product numbers correct as of November 2009. These may be subject to change.)



(N2QAYB000463)

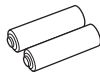
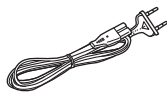

## 1 Remote control

## 1 AC mains lead

For use with this unit only. Do not use it with other equipment. Also, do not use cords for other equipment with this unit.

## 1 RF coaxial cable

## 2 Batteries

for remote control

# The remote control information

## ■ Batteries

- Insert so the poles (+ and -) match those in the remote control.

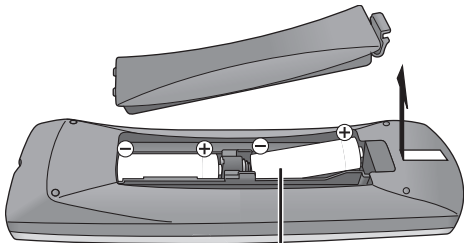

R6/LR6, AA

- Use alkaline or manganese batteries.
- Do not mix old and new batteries.
- Do not use different types at the same time.
- Do not heat or expose to flame.
- Do not leave the battery(ies) in an automobile exposed to direct sunlight for a long period of time with doors and windows closed.
- Do not take apart or short circuit.
- Do not attempt to recharge alkaline or manganese batteries.
- Do not use batteries if the covering has been peeled off.

Mishandling of batteries can cause electrolyte leakage which can damage items the fluid contacts and may cause a fire.

Remove if the remote control is not going to be used for a long period of time. Store in a cool, dark place.

Remote control operations (⇒ 6)

## ■ Use

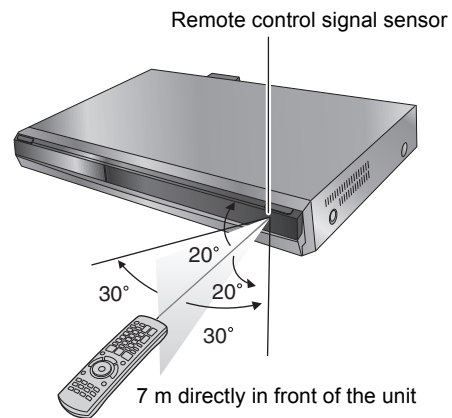

The distance and angles are an approximate.

# HDD (Hard disk drive) handling care

The HDD is a high precision recording instrument and because of its long recording capability and high speed operation it is a very special device that is easily susceptible to damage.

As a basic rule, save important content to a disc as backup.

## ■ The HDD is a device that is not built to withstand vibration/shock or dust

Depending on the setup environment and handling of the HDD some content may become damaged and play and recording may no longer be possible. Especially during operation, do not subject the unit to any vibration, shock, or remove the AC mains lead from the household mains socket. In the event of a power failure during recording or play, the content may be damaged.

## ■ The HDD is a temporary storage device

The HDD is not an everlasting storage device for recorded content. Use the HDD as a temporary storage place for one-off viewing, editing, or copying. It is recommended to save the recorded content on a disc or to keep the original data or CDs that they were copied from.

## ■ Immediately save (backup) all content as soon as you feel there may be a problem with the HDD

If there is an irregularity within the HDD, repetitive strange sounds or problems with picture (block noise, etc.) may result. Using the HDD in this condition may worsen the problem and in the worst case the HDD may no longer be usable. As soon as you notice this type of problem, copy all content to disc and request service. Recorded content (data) on a HDD that has become unusable is unrecoverable.

● When the unit is turned on or off, there may be an unexpected sound. This does not indicate a problem with this unit.

### ■ Setup precautions

● Do not place in an enclosed area where the rear cooling fan and the cooling vents on the side are covered up.

● Place the unit on a surface that is flat and not subject to vibration or impact.

● Do not place on anything that generates heat like a video cassette recorder, etc.

● Do not place in an area often subject to temperature changes.

● Place in an area where condensation does not occur. Condensation is a phenomenon where moisture forms on a cold surface when there is an extreme change in temperature. Condensation may cause internal damage to the unit.

● Conditions where condensation may occur  
– When there is an extreme change in temperature (moving from a very hot location to a very cold location, or vice versa, or when subjected to an air conditioner or when cooled air directly impacts the unit). When the HDD (warms during operation) is subjected to cold air, condensation may form on the inside of the HDD and may cause damage to the HDD heads, etc.  
– When there is high humidity or a lot of steam in the room.  
– During the rainy season.

– When there is an extreme change in temperature (moving from a very hot location to a very cold location, or vice versa, or when subjected to an air conditioner or when cooled air directly impacts the unit). When the HDD (warms during operation) is subjected to cold air, condensation may form on the inside of the HDD and may cause damage to the HDD heads, etc.  
– When there is high humidity or a lot of steam in the room.  
– During the rainy season.

In the above situation, **without turning the unit on**, let the unit adjust to the room temperature and wait 2–3 hours until condensation is gone.

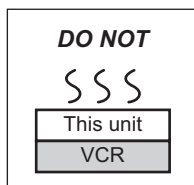

### ■ Cigarette smoke etc. causes malfunction or breakdown

The unit may breakdown if cigarette smoke or bug spray/vapor, etc. gets inside the unit.

### ■ While operating

● Do not move the unit or subject to vibration or impact. (The HDD may become damaged.)

● Do not remove the AC mains lead from the household mains socket, or flip the power breaker switch.

While the unit is on, the HDD is rotating at high speed. Sound or movement due to rotation is normal.

### ■ When moving the unit

- ① Turn the unit off. (Wait until "BYE" disappears from the display.)
- ② Remove the AC mains lead from the household mains socket.
- ③ Move only after the unit has come to a complete stop (approx. 2 minutes) in order to avoid subjecting to vibration and shock. (Even after turning the unit off, the HDD continues operating for a short time.)

## ■ HDD recording time remaining

This unit records using a VBR (Variable bit rate) data compression system to vary recorded data segments to match video data segments which may cause differences in the displayed amount of time and space remaining for recording.

If the remaining amount of time is insufficient, delete any unwanted titles to create enough space before you start recording. (Deleting a Playlist (Video) will not increase the amount of time.)

## ■ Indemnity concerning recorded content

Panasonic does not accept any responsibility for damages directly or indirectly due to any type of problems that result in loss of recording or edited content (data), and does not guarantee any content if recording or editing does not work properly. Likewise, the above also applies in a case where any type of repair is made to the unit (including any other non-HDD related component).

## Unit care

The precision parts in this unit are readily affected by the environment, especially temperature, humidity, and dust. Cigarette smoke also can cause malfunction or breakdown.

To clean this unit, wipe with a soft, dry cloth.

- Never use alcohol, paint thinner or benzine to clean this unit.
- Before using chemically treated cloth, carefully read the instructions that came with the cloth.

Observe the following points to ensure continued listening and viewing with pleasure.

Dust and dirt may adhere to the unit's lens over time, making it impossible to record or play discs.

Use the **DVD lens cleaner** (not included) about once every year, depending on frequency of use and the operating environment. Carefully read the lens cleaner's instructions before use.

DVD lens cleaner: RP-CL720E

- This lens cleaner may not be for sale depending on the region.

**DO NOT**  
Do not place the unit on amplifiers or equipment that may become hot.  
The heat can damage the unit.

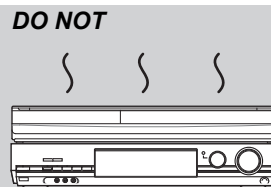

### Note

Do not obstruct the rear panel's internal cooling fan.

**Before moving the unit, ensure the disc tray is empty. Failure to do so will risk severely damaging the disc and the unit.**

## Remote control

Instructions for operations are generally described using the remote control.

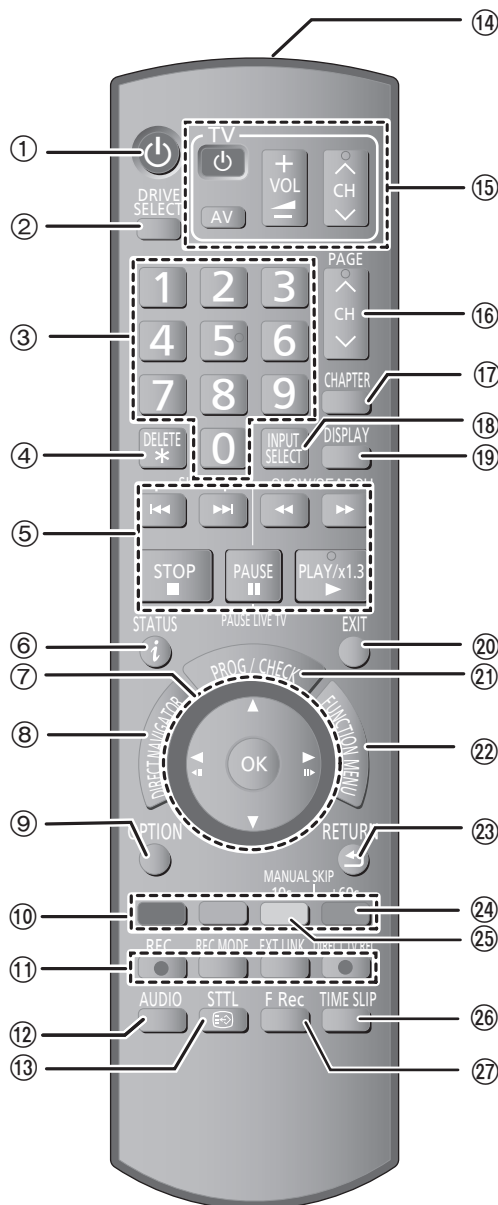

- ① Turn the unit on (⇒ 10)
- ② Select drive [HDD or DVD] (⇒ 17, 18)  
Drive changes each time you press [DRIVE SELECT].
- ③ Select channels and title numbers, etc./Enter numbers
- ④ To delete unwanted recorded titles, timer programmes, still pictures or music (⇒ 19, 25, 41)
- ⑤ Basic operations for recording and play  
[PAUSE LIVE TV] Pause the TV programme you are watching (⇒ 33)
- ⑥ Show digital channel information (⇒ 16)/Show status messages (⇒ 55)
- ⑦ Selection/OK, Frame-by-frame (⇒ 26)
- ⑧ Show DIRECT NAVIGATOR (⇒ 27, 36)
- ⑨ Show OPTION menu (⇒ 36)  
By using the OPTION button, you may access the various functions (Slideshow, Standby Settings, etc.) quickly and easily.
- ⑩ Colour buttons  
- for switching the DIRECT NAVIGATOR screen (⇒ 27, 30, 32)  
- for switching VIDEO/Playlists (⇒ 47)  
- for switching PICTURE/Playlists (⇒ 50)  
- for deactivating timer programme (⇒ 25)  
- for selecting character type when entering text (⇒ 44)  
- for tuning settings (⇒ 59)
- ⑪ Recording functions
  - [REC] Start recording (⇒ 18)
  - [REC MODE] Change recording mode (⇒ 18)
  - [EXT LINK] Linked timer recordings with external equipment (⇒ 23)
  - [DIRECT TV REC] Direct TV Recording (⇒ 34)
- ⑫ Select audio (For playback) (⇒ 26)
- ⑬ Show subtitles (Subtitles can be viewed if the digital broadcast programme has subtitles.) (⇒ 16)
- ⑭ Transmit the remote control signal
- ⑮ Television operations (⇒ 66)
- ⑯ Channel select (⇒ 16)
- ⑰ Create chapter (⇒ 26)
- ⑱ Input select (AV1 or AV2) (⇒ 23)
- ⑲ Show on-screen menu (⇒ 54)  
Menu for disc playback and changing DVB multi audio or subtitle etc.
- ⑳ Exit the menu screen
- ㉑ Show Timer Recording screen (⇒ 24)
- ㉒ Show FUNCTION MENU (⇒ 33)  
By using the FUNCTION MENU you may access the main functions (Playback, Recording, etc.) quickly and easily.
- ㉓ Return to previous screen
- ㉔ Skip approx. 1 minute forward (⇒ 26)
- ㉕ Skip approx. 10 seconds backward (⇒ 26)
- ㉖ Skip the specified time (⇒ 26)
- ㉗ Start Flexible Recording (⇒ 22)

## The unit's display

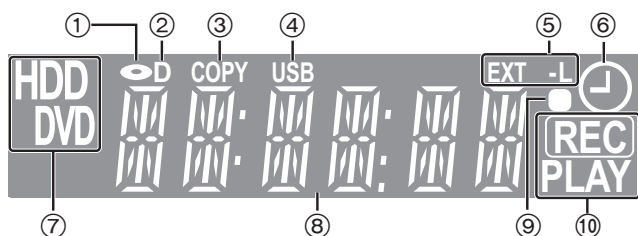

- ① Disc indicator
- ② Digital broadcast indicator  
Lights when the unit is receiving digital broadcast.
- ③ Copying indicator
- ④ USB port indicator
- ⑤ Linked timer recordings with external equipment indicator
- ⑥ Timer recording indicator
- ⑦ Drive [HDD or DVD] indicator

- ⑧ Main display section indicator
- ⑨ Remote control visual feedback  
This flashes when it is operated by the remote control.
- ⑩ Recording/Playback indicator

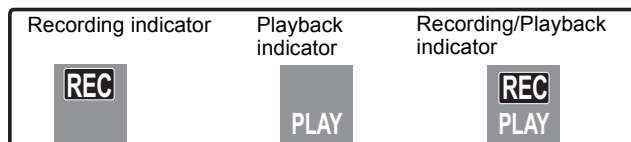

## Main unit

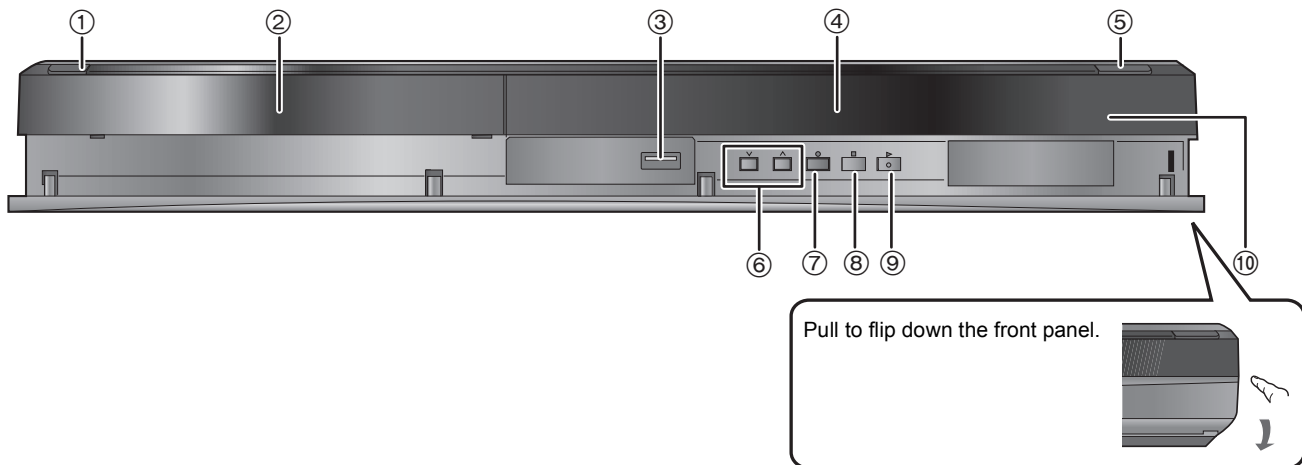

- ① **Standby/on switch (⏻/⏻) (⇒ 10)**  
Press to switch the unit from on to standby mode or vice versa. In standby mode, the unit is still consuming a small amount of power.
- ② Disc tray (⇒ 15)
- ③ USB port (⇒ 15)
- ④ Display (⇒ 6)
- ⑤ Open/Close disc tray (⇒ 15)
- ⑥ Channel select (⇒ 16)

- ⑦ Start recording (⇒ 18)/Specify a time to stop recording (⇒ 18)
  - ⑧ Stop (⇒ 17, 18, 26)
  - ⑨ Start play (⇒ 17)
  - ⑩ Remote control signal sensor (⇒ 4)
- Rear panel terminals (⇒ 8, 9, 66, 67)

## Easy access to various functions — FUNCTION MENU Display

"FUNCTION MENU" automatically appears when you turn the power on. (When "FUNCTION MENU Display" is set to "On" in the Setup menu)  
You can access the main function quickly and easily.

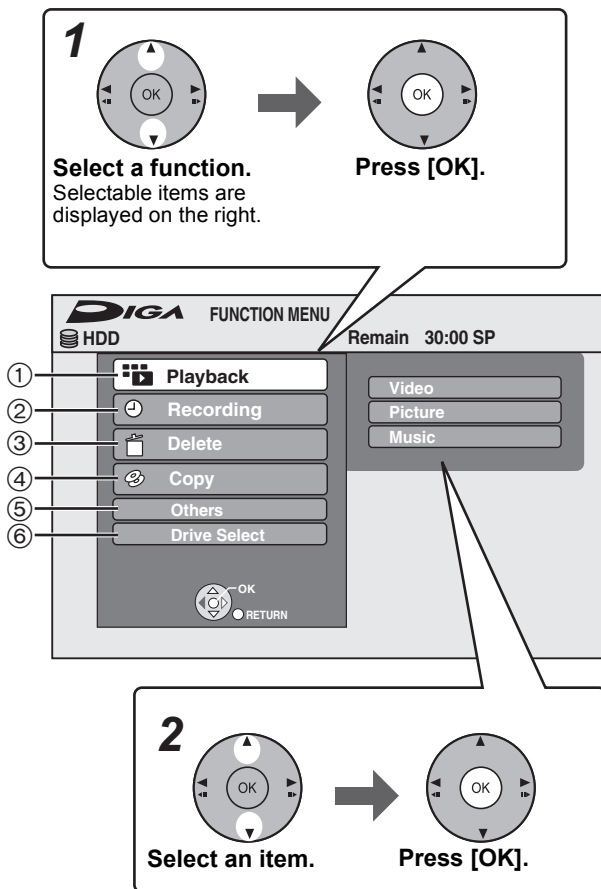

① <b>Playback</b> Video (⇒ 17, 27) DivX (⇒ 28) Picture (⇒ 30) Music (⇒ 29, 32) Top Menu (⇒ 17) Menu (⇒ 17)	Select when you wish to playback the contents. The DIRECT NAVIGATOR screen or menu screen etc. will be displayed.
② <b>Recording (⇒ 24)</b>	Select when you wish to perform manual timer recording, or check the timer recording. The timer recording list will be displayed.
③ <b>Delete</b> Video (⇒ 19) Picture (⇒ 41) Music (⇒ 41)	Select the title or file type you wish to delete. The DELETE Navigator screen will be displayed.
④ <b>Copy</b> Video (HDD to DVD) (⇒ 46) Advanced Copy (⇒ 47) Copy Music CD (⇒ 52) Copy Music (⇒ 52)	Select the copy method.
⑤ <b>Others</b> Playlists (⇒ 38, 42) Flexible Rec (⇒ 22) HDD Management (⇒ 56) DVD Management (⇒ 56) Setup (⇒ 59)	Select and execute a function other than those above, such as recording or setting.
⑥ <b>Drive Select</b> HDD DVD USB	Change which drive is used.

### Note

If you do not need to display FUNCTION MENU when turning the unit on, set "FUNCTION MENU Display" to "Off" in the Setup menu (⇒ 62).

# STEP 1 Connection

## Using a 21-pin Scart cable

- You can use a variety of Q Link functions by connecting the unit to a Q Link compatible television (⇒ 34).
- You can enjoy high-quality viewing by connecting the unit to an RGB compatible television (⇒ 79).

### Required setting

“AV1 Output” in the Setup menu (⇒ 63)

- Before connection, turn off all equipment and read the appropriate operating instructions.
- Select the connection pattern that matches your environment from pattern A–B. Confirm connections not listed below with your dealer.
- Refer to “Additional connections” (⇒ 66) for connection using other terminals and connection with other equipment.

## When the unit is not to be used for a long time

To save power, unplug it from the household mains socket. This unit consumes a small amount of power, even when it is turned off [approx. 0.3 W (“Power Save in Standby” is activated and “RF OUT ( Aerial Signal )” is set to “Off”).]

## A Connecting a television

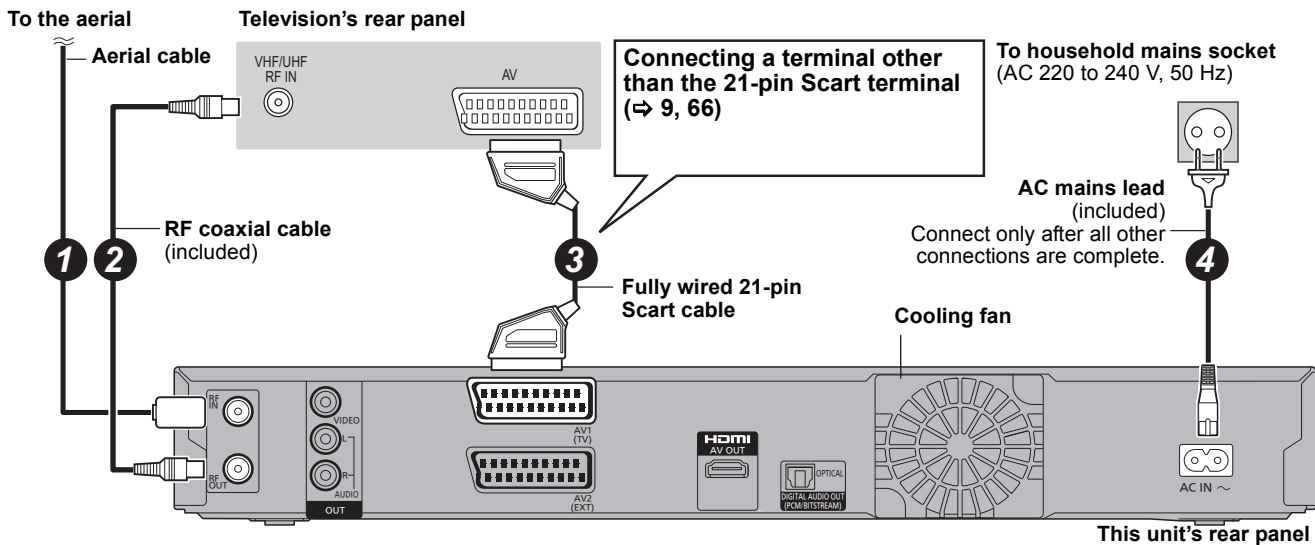

## B Connecting a television and digital satellite receiver

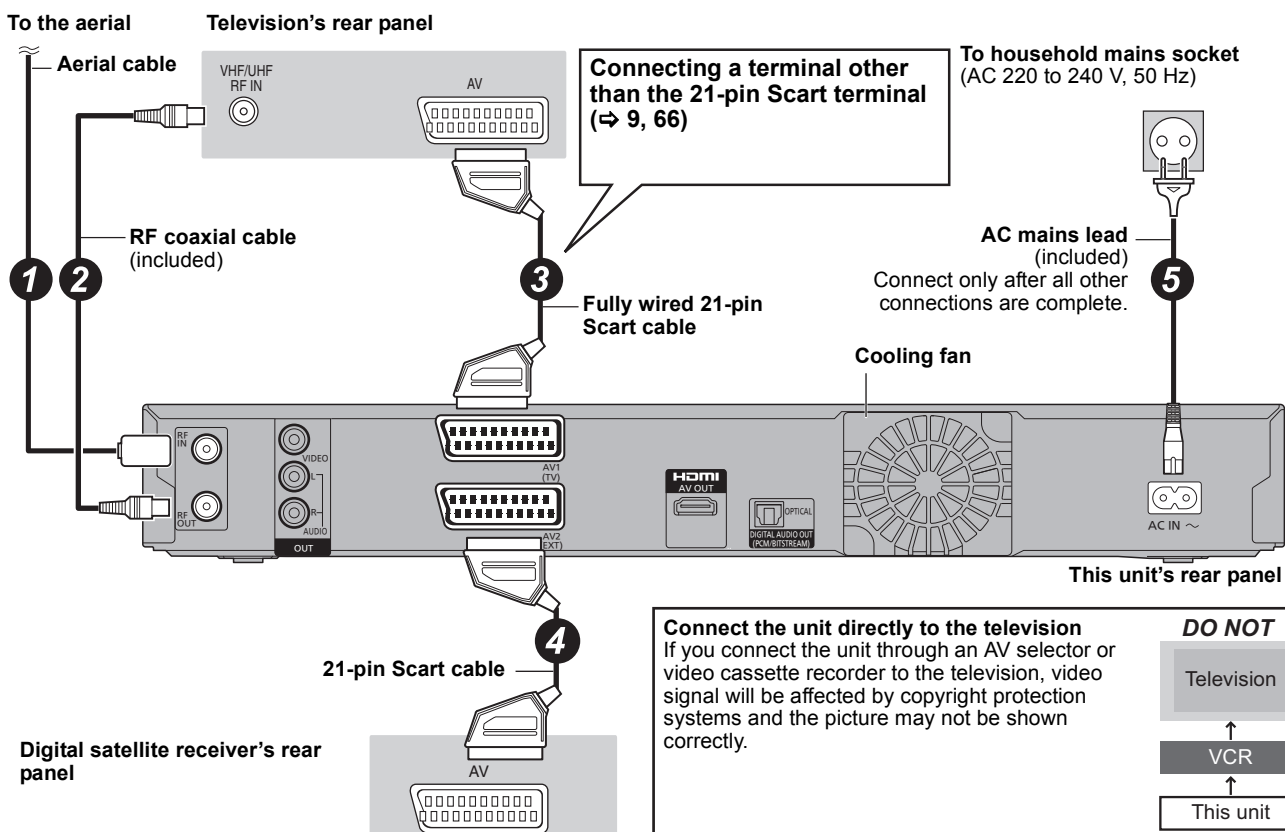

### Required setting

“AV2 Input” setting in the Setup menu (⇒ 64)

**Connect the unit directly to the television**  
If you connect the unit through an AV selector or video cassette recorder to the television, video signal will be affected by copyright protection systems and the picture may not be shown correctly.

### DO NOT

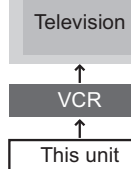

- When connecting to a television with a built-in VCR  
Connect to the input terminals on the television side if there are both television and VCR input terminals.



You can enjoy high-quality picture by adding the HDMI cable connection to the 21-pin Scart cable connection between this unit and your TV.

## Connecting to a TV with an HDMI (High Definition Multimedia Interface) cable

When connected to an HDMI compatible unit, an uncompressed digital audio and video signal is transmitted. You can enjoy high quality, digital video and audio with just one cord. When connecting to an HDMI-compatible HDTV (High Definition Television), the output can be switched to 1080p, 1080i or 720p HD video.

- This unit incorporates HDMI™ (V.1.3a with Deep Colour) technology.
- Video sources converted to 1920×1080 resolution, while of high quality, will exhibit somewhat lower subjective image resolution than true, native 1080p full-HD sources. See dealer for details.
- Please use High Speed HDMI Cables that have the HDMI logo (as shown on the cover).
- When setting video output to “1080p”, please use the HDMI cables 5.0 meters or less.

### Regarding VIERA Link “HDAVI Control™” function

When connecting with a Panasonic TV (VIERA) or a receiver equipped with the “HDAVI Control” function, linked operations would be possible. [⇒ 34, Linked operations with the TV (VIERA Link “HDAVI Control™/Q Link)]

- **Non-HDMI-compliant cables cannot be utilised.**
- **It is recommended that you use Panasonic’s HDMI cable.**

Recommended part number:

RP-CDHS15 (1.5 m), RP-CDHS30 (3.0 m), RP-CDHS50 (5.0 m), etc.

#### Connecting with a Panasonic TV (VIERA)

If the 21-pin Scart cable is connected, the following functions are available.

- Download from the TV (⇒ 34)
- Direct TV Recording (⇒ 34)
- Watching pictures from digital satellite receiver  
(In this case, make sure to switch the television input to “AV”.)

#### Required setting

- Set “Digital Audio Output” to “HDMI and Optical” (⇒ 63).  
(The default setting is “HDMI and Optical”.)

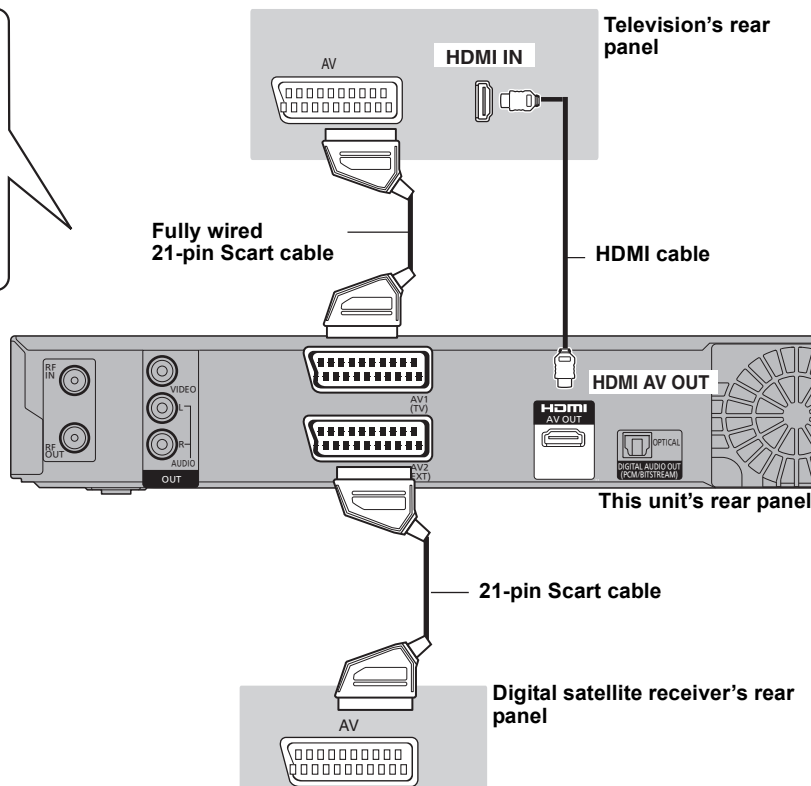

## Connecting with an HDMI compatible television and receiver

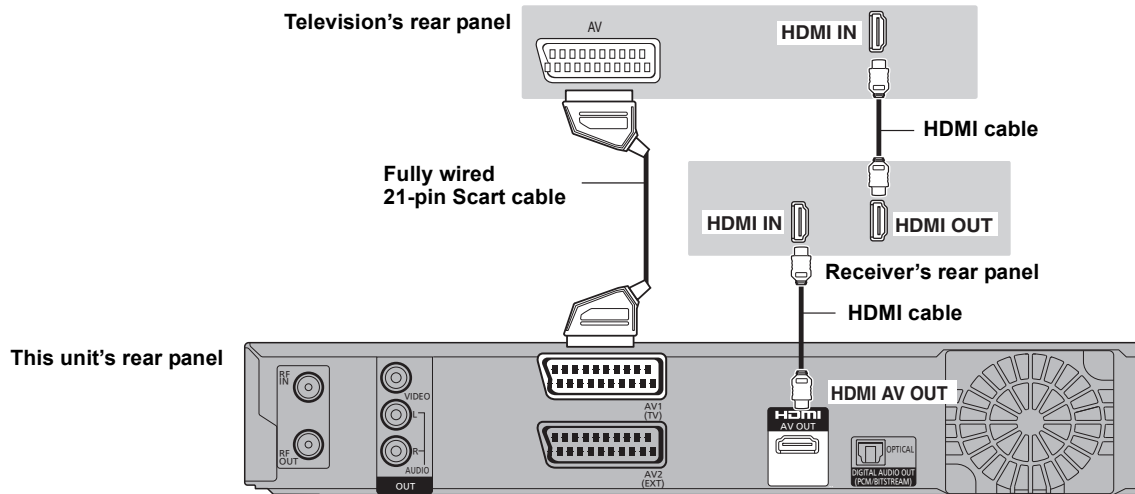

#### Note

- If you are connecting to a TV that is only compatible with 2 channel audio output, audio with 3 channels or more will be down mixed (⇒ 78) and output as 2 channels, even if connecting with an HDMI cable. (Some discs cannot be down mixed.)
- You cannot connect this unit to DVI devices that are incompatible with HDCP.  
For units compatible with HDCP (High-Bandwidth Digital Content Protection) copyright protection that are equipped with a digital DVI input terminal (PC monitors, etc.):  
Depending on the unit, images may not be displayed properly or at all when connecting with a DVI/HDMI switching cable. (Audio cannot be output.)

# STEP 2 Channel reception settings and TV aspect settings

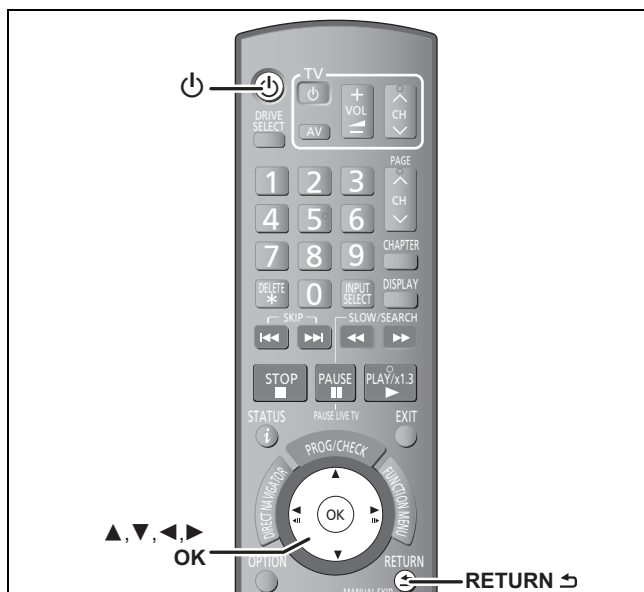

**1 Turn on the television and select the appropriate AV input to suit the connections to this unit.**

**2 Press [Power] to turn the unit on.**

When connecting to a television that has the VIERA Link or Q Link functions (⇒ 34), downloading from the television starts. You can download the tuning positions from the television for the channels in this unit's channel coverage.

**If the Country setting menu appears on the television. Press [Up], [Down] to select the country and press [OK].**

**DVB Auto Setup starts.**

The unit will search for the terrestrial digital channels. TV channels will be located and stored ready for use. This takes 5 minutes.

DVB Auto Setup			
Scan	CH 5	69	
CH	Channel Name	Type	Quality
1	ABC	TV	9
2	ABC 2	Data	9

**3 Press [Up], [Down] to select "On", "Off" or "On Timer" and press [OK] when the "Power Save in Standby" setting menu appears.**

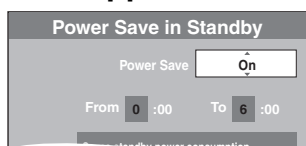

- On:** It will go into the Power Save in Standby mode when the unit is in standby mode.
- Off:** It is possible to start quickly from the standby mode. (Quick Start mode)
- On Timer:** Press [Up], [Down], [Left], [Right] to set the start and stop time and then press [OK].
  - "Power Save in Standby" is set to activate during the setting time period.

The features of the Power Save in Standby function when the unit is in standby mode are as below.

Power Save in Standby	Activated (On/On Timer) <sup>※1</sup>	Deactivated (Off)
Power consumption	Approx. 0.3 W <sup>※3</sup>	Approx. 11 W
Startup time	Not Quick	Quick <sup>※2</sup>
Watching the picture (e.g. Pay TV) from the device connected to AV2	Cannot do	Can do

※1 "Unit's Display" is set to "Automatic" in the Setup menu. (⇒ 62)

※2 It is possible to startup and start recording within several seconds.

– Depending on the type of TV or the connected terminal, it may take time to display the screen.

※3 When "RF OUT ( Aerial Signal )" is set to "Off" in the Setup menu (⇒ 65)

**If the TV aspect setting screen appears on the television.**

**Press [Up], [Down] to select the TV aspect and press [OK].**

● **16:9:**

When connected to a 16:9 widescreen television

● **Pan & Scan:**

When connected to a 4:3 aspect television, side picture is trimmed for 16:9 picture (⇒ 78).



● **Letterbox:**

When connected to a 4:3 aspect television, 16:9 picture is shown in the letterbox style (⇒ 78).



When television picture appears, set up is complete.

**To stop partway**

Press [RETURN ↵].

■ **If the clock setting menu appears**

Set the clock manually (⇒ 64).

■ **To confirm that stations have been tuned correctly (⇒ 60)**





■ **To restart set up (⇒ 59)**

**The auto setup screens may be displayed in French, Italian or Spanish. After completing step 3, change the on-screen display to English in the following steps.**

- ① Press [FUNCTION MENU].
- ② Press [Up], [Down] to select
  - "Autres" (French)
  - "Altre funzioni" (Italian)
  - "Otras" (Spanish)
 and press [OK].
- ③ Press [Up], [Down] to select
  - "Configuration" (French)
  - "Impostazioni" (Italian)
  - "Configuración" (Spanish)
 and press [OK].
- ④ Press [Up], [Down] to select
  - "Affichage" (French)
  - "Display" (Italian)
  - "Display" (Spanish)
 and press [Right].
- ⑤ Press [Up], [Down] to select
  - "Langue" (French)
  - "Lingua" (Italian)
  - "Idioma" (Spanish)
 and press [OK].
- ⑥ Press [Up], [Down] to select "English" and press [OK].
- ⑦ Press [EXIT].

## HDD and discs you can use for recording and play

(○: Possible, -: Impossible)

Disc type Standard symbol	Logo	Data that can be recorded and played	Rewritable	Play on other players*1	Recording 16:9 aspect picture*2	Copy-once recording (CPRM)
Hard disk drive (HDD) <b>HDD</b>	—	Video Still picture Music	○	—	○	○
DVD-RAM <b>RAM</b>		Video Still picture	○	○	○	○ CPRM (⇒ 78) compatible discs only.
DVD-R <b>-R</b> before finalisation <b>DVD-V</b> after finalisation (Video only)		Video*4 or Still picture*4	—	○	○	—
DVD-R DL*3 <b>-R DL</b> before finalisation <b>DVD-V</b> after finalisation		Video	—	○	○	—
DVD-RW <b>-RW(V)</b> before finalisation <b>DVD-V</b> after finalisation		Video	○	○	○	—
+R <b>+R</b> before finalisation <b>DVD-V</b> after finalisation	—	Video	—	○	— (4:3 aspect)	—
+R DL*3 <b>+R DL</b> before finalisation <b>DVD-V</b> after finalisation	—	Video	—	○	— (4:3 aspect)	—
+RW <b>+RW</b>	—	Video	○	○	— (4:3 aspect)	—

\*1 **-R -R DL -RW(V) +R +R DL**

Finalisation is needed for playback on other equipment (⇒ 58).

**RAM** can be played back on Panasonic DVD recorders and DVD-RAM compatible DVD players.

**-R DL**, **+R DL** or **+RW** can be played back only on equipment compatible with these discs.

\*2 For further information (⇒ 20, Notes for recording)

\*3 **-R DL +R DL** You cannot directly record to these discs (⇒ right).

\*4 **-R** Videos and still pictures cannot be mixed on one disc.

● **RAM -RW(V) +R +R DL +RW** To use a new disc, formatting is necessary (⇒ 57).

● **+RW** If the disc failed to play on other equipment, we recommend you create top menu (⇒ 58).

● Use of Panasonic discs is recommended.

For available recording times for different discs under different recording modes, see "Recording modes and approximate recording times" (⇒ 21).

● Formatting and/or recording/initializing constraints may prevent you from playing or recording certain discs.

● Please see specifications (⇒ 77) for compatible disc versions and recording speeds.

### Recording format

This unit records video in the following formats.

#### DVD Video Recording format **HDD RAM**

This is a recording method which allows you to record and edit television broadcasts and so on.

● You can delete unwanted parts of a title, create Playlists (Video), etc.

● The broadcasts that allow "One time only recording" can be recorded to a CPRM compatible disc.

#### DVD-Video format **-R -R DL -RW(V)**

This recording method is the same as commercially available DVD-Video.

● The broadcasts that allow "One time only recording" cannot be recorded even if using a CPRM compatible disc.

● After finalising the disc, you can play the disc on DVD players and other equipment.

#### +VR (+R/+RW Video Recording) format **+R +R DL +RW**

This is a method for recording moving pictures to +R/+RW discs. You can playback such discs recorded in this method in a similar way as contents recorded in the DVD-Video format.

● The broadcasts that allow "One time only recording" cannot be recorded.

● After finalising the disc or creating the top menu, you can play the disc on DVD players and other equipment.

### Note

● When "Rec for High Speed Copy" is set to "On", the restrictions on secondary audio recording are also applied to DVD-RAM. Turn this setting "Off" if high speed copy to **-R -R DL -RW(V) +R +R DL +RW** is not necessary (The default setting is "On". ⇒ 61).

● +R discs recorded with this unit and +R discs recorded with another Panasonic DVD Recorder may be incompatible. However, discs that are finalised are compatible and can be played.

● This unit cannot record NTSC signals to discs that already have PAL signal recordings. (However, both types of programmes can be recorded onto the HDD.)

● You may not be able to record depending on the condition of the discs and you may not be able to play due to the condition of the recording.

### You cannot directly record to a DVD-R DL and +R DL disc on this unit.







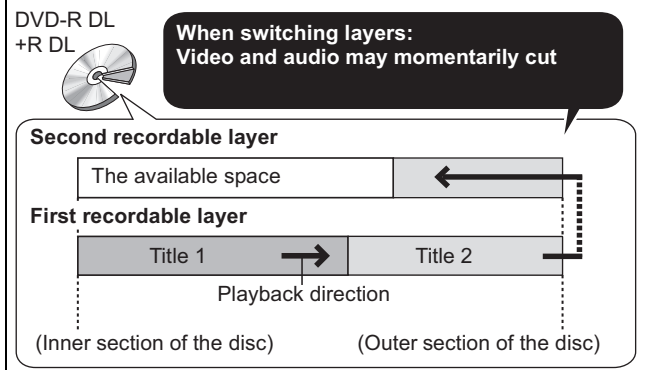

Record to the HDD and then copy to the disc.

### When playing DVD-R DL (Dual Layer, single-sided) and +R DL (Double Layer, single-sided)

DVD-R DL (Dual Layer, single-sided) and +R DL (Double Layer, single-sided) discs have two writable layers on one side. If there is not enough space on the first layer to record a programme, the remainder is recorded on the second layer. When playing a title recorded on both layers, the unit automatically switches between layers and plays the title in the same way as a normal programme. However, video and audio may momentarily cut out when the unit is switching layers.



## Play-only discs

Disc type	Logo	Standard symbol	Uses
DVD-Video	 	<b>DVD-V</b>	High quality movie and music discs
DVD-RW (DVD Video Recording format)		<b>-RW(VR)</b>	DVD-RW video recorded on another DVD recorder <ul style="list-style-type: none"> <li>You can play programmes that allow One time only recording if they have been recorded onto a CPRM compatible disc.</li> <li>By formatting (⇒ 57) the disc, you can record onto it in DVD-Video format.</li> <li>It may be necessary to finalise the disc on the equipment used for recording.</li> </ul>
DVD-R DVD-R DL	 	<b>DivX®/MP3/ JPEG</b>	<ul style="list-style-type: none"> <li>DVD-R and DVD-R DL with video recorded in DivX</li> <li>DVD-R and DVD-R DL with music recorded in MP3</li> <li>DVD-R and DVD-R DL with still pictures recorded in JPEG</li> </ul>
CD		<b>CD</b>	Recorded audio and music (including CD-R/RW*)
	—	<b>DivX/MP3/ JPEG</b>	<ul style="list-style-type: none"> <li>CD-R and CD-RW with video recorded in DivX</li> <li>CD-R and CD-RW with music recorded in MP3</li> <li>CD-R and CD-RW with still pictures recorded in JPEG</li> </ul>
Video CD		<b>VCD</b>	<ul style="list-style-type: none"> <li>Recorded music and video (including CD-R/RW*)</li> </ul>
SVCD			

\* Close the session after recording. Play may be impossible on some discs due to the condition of the recording.

- The producer of the disc can control how discs are played. So you may not always be able to control play as described in these operating instructions. Read the disc's instructions carefully.
- Operation and sound quality of CDs that do not conform to CD-DA specifications (copy control CDs, etc.) cannot be guaranteed.

### Discs that cannot be played

- 2.6 and 5.2 GB DVD-RAM, 12 cm
- 3.95 and 4.7 GB DVD-R for Authoring
- DVD-R, DVD-R DL, DVD-RW, +R, +R DL recorded on another unit and not finalised (⇒ 78).
- Discs recorded with AVCHD format.
- DVD-Video with a region number other than "2" or "ALL"
- DVD-Audio
- Blu-ray, HD DVD
- DVD-ROM, +R (8 cm), CD-ROM, CDV, CD-G, Photo CD, CVD, SACD, MV-Disc, PD
- DVD-RAM with a cartridge (TYPE 1)

### Types of disc or title recorded on HDD for the type of connected TV

When you use the discs recorded either PAL or NTSC, or playback a title recorded on HDD using PAL or NTSC, refer to this table.

(○: Possible to view, -: Impossible to view)

TV type	Disc/Titles recorded on HDD	Yes/No
Multi-system TV	PAL	○
	NTSC	○
PAL TV	PAL	○
	NTSC	○*1 (PAL60)
NTSC TV	PAL	-
	NTSC	○*2

\*1 If your television is not equipped to handle PAL 525/60 signals the picture will not be shown correctly.

\*2 Select "NTSC" in "TV System" (⇒ 63).

- When playing back a disc or title recorded on the HDD, ensure that you match the "TV System" setting to the disc or title (PAL or NTSC) (⇒ 63).

## USB memories you can use on this unit

<b>Compatible USB memories</b>	<b>USB memories which are defined as USB mass storage class, and digital cameras that use PTP protocol:</b> – USB memories that support USB 1.0/1.1 and USB 2.0 Full Speed/High Speed. ● USB memories of up to 128 GB can be used. ● USB memories that support bulk only transfer. CBI (Control/Bulk/Interrupt) is not supported. ● Digital Cameras which require additional programme installation when connected to a PC are not supported. ● MTP (Media Transport Protocol) device is not supported. ● A multi-port USB card reader is not supported.		
<b>Format</b>	FAT16 and FAT32 file systems are supported. ● UDF/NTFS/exFAT file system is not supported. ● Depending on the sector size, some files may not work. ● Only the first partition on USB memories with multi-partition is supported.		
<b>Indicated in these instructions by</b>	<b>USB</b>		
<b>Data that can be played or copied</b>	(○: Possible, -: Impossible)		
<b>File format</b>	<b>DivX</b>	<b>MP3</b>	<b>Still pictures (JPEG)</b>
<b>Playing</b>	○*	○	○
<b>Copying to HDD</b>	-	○	○
<b>Instructions</b>	You can play DivX files recorded with a computer onto the USB memory (⇒ 28).	You can play and copy to HDD MP3 files recorded with a computer onto the USB memory (⇒ 29, 52).	You can play and copy to HDD or DVD-RAM still pictures recorded with a computer onto the USB memory (⇒ 30, 50, 51).

\* DivX VOD contents recorded on USB memories cannot be played back. (⇒ 29)

● Despite meeting the conditions mentioned above, there may be USB memories that cannot be used for this unit.

● If a Panasonic digital video camera with HDD etc. is connected to this unit's USB port, you can copy the SD Video recorded with the camera to this unit's HDD or DVD-RAM.

### Note

● This unit's USB port does not support bus-powered USB device.

# Regarding DivX files, Music files and still pictures (JPEG)

## DivX

Playable media	<b>-R -R DL CD USB</b> *1
File format	DivX • Files must have the extension “.DIVX”, “.divx”, “.AVI” or “.avi”.
Number of folders	Maximum number of folders recognizable: 300 folders (including the root folder)
Number of files	Maximum number of files recognizable*2: 200 files
Support version	Certified to the DivX Home Theater Profile V3.0. Video – Number of stream: Up to 1 – Codec: DIV3, DIV4, DIVX, DV50 – 16 × 16 to 720 × 576 (25 fps) – 16 × 16 to 720 × 480 (30 fps) – Aspect Ratio: 10:11, 40:33, 16:11, 12:11, 1:1 Audio – Number of stream: Up to 8 – Format: MP3, MPEG, Dolby Digital – Multi channel: Dolby Digital is possible. MPEG multi is 2 ch conversion. – Bitrate: 16 kbps to 320 kbps (MP3/MPEG), 32 kbps to 448 kbps (Dolby Digital) – Sampling frequency.: 16 kHz/22.05 kHz/24 kHz/32 kHz/44.1 kHz/48 kHz (MP3/MPEG)/32 kHz/44.1 kHz/48 kHz (Dolby Digital)

## MP3

Playable media	<b>HDD -R -R DL CD USB</b>
File format	MP3 • Files must have the extension “.mp3” or “.MP3”.
Number of folders (groups or albums)	Maximum number of folders (groups or albums) recognizable: 300 folders (groups or albums) (including the root folder)
Number of files (tracks)	Maximum number of files (tracks) recognizable*2: 3000 files (tracks)
Bit rates	32 kbps to 320 kbps
Sampling frequency	16 kHz/22.05 kHz/24 kHz/32 kHz/44.1 kHz/48 kHz
ID3 tags	compatible ( <b>HDD USB</b> )

• If there is a large amount of still picture data etc. within a MP3 file, play may not be possible.

## Still pictures (JPEG\*3)

Playable media	<b>HDD RAM -R -R DL CD USB</b>
File format	JPEG • Files must have the extension “.jpg” or “.JPG”.
Compatible pixels	Between 34×34 and 6400×6400 (Sub sampling is 4:2:2 or 4:2:0)
Number of folders*4	<b>-R -R DL CD USB</b> Maximum number of folders recognizable: 300 folders <b>HDD RAM</b> This unit can handle a maximum of 300 folders
Number of files*4	<b>-R -R DL CD USB</b> Maximum number of files recognizable*2: 3000 files <b>HDD RAM</b> This unit can handle a maximum of 3000 files
MOTION JPEG PROGRESSIVE JPEG	Not supported

\*1 **USB** DivX VOD contents cannot be played back.

\*2 Total number of recognizable file including MP3, JPEG, DivX and other types of files is 4000.

\*3 It may take a few moments for still pictures to display.

\*4 When there are many files and/or folders, some files may not display or be playable.

## **-R -R DL CD**

- Compatible formats: ISO9660 level 1 or 2 (except for extended formats) and Joliet
- This unit is compatible with multi-session/border (except for DVD-R DL), but reading or play of the disc may take time if there are a lot of sessions.
- Operation may take time to complete when there are many files (tracks) and/or folders (groups or albums) and some files (tracks) may not display or be playable.
- English alphabet and Arabic numerals are displayed correctly. Other characters may not be displayed correctly.
- The display order on this unit may differ from how the order is displayed on a computer.
- Depending on how you create the disc (writing software), files (tracks) and folders (groups or albums) may not play in the order you numbered them.
- This unit is not compatible with packet-write format.
- Depending on the recording conditions, the disc may not be played.

## **HDD RAM**

- Compatible formats: DCF\*5 compliant (Content recorded on a digital camera, etc.)

\*5 Design rule for Camera File system: unified standard established by Japan Electronics and Information Technology Industries Association (JEITA).

## ■ Structure of folders displayed by this unit

You can play Music files (MP3) and still pictures (JPEG) on this unit by making folders as shown below. However depending on the method of writing data (writing software), play may not be in the order you numbered the folders.

### Structure of MP3 folders

**-R -R DL CD USB**

Prefix with 3-digit numbers in the order you want to play them.

### Structures of still picture folders

**-R -R DL CD USB**

Files inside a folder are displayed in the order they were updated or taken.

### **RAM**

Folders can be created on other equipment.

\* These folders cannot be selected as a copying destination.

• If a folder name or file name has been input using other equipment, the name may not be displayed properly or you may not be able to play or edit the data.

## Inserting discs

- 1 Press [**▲** OPEN/CLOSE] to open the tray.

Insert label-up.

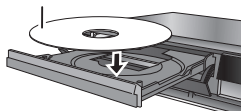

- 2 Press [**▲** OPEN/CLOSE] to close the tray.

### Automatic drive select function

#### DVD-V VCD

- If the unit is recording to the HDD or stopped, it automatically switches to the DVD drive when a disc is inserted.
- If you eject a disc and close the disc tray, the HDD drive is automatically selected.

#### Note

- When using DVD-RAM or DVD-R, remove the disc from the cartridge. Cartridge discs cannot be used.
- **RAM** It is not possible to record or play continuously from one side of a double sided disc to the other. You will need to eject the disc and turn it over.

## Inserting, removing the USB memory

### Inserting the USB memory

- Before inserting any USB memory to this unit, ensure that the data stored therein has been backed up.
- Check the orientation of the USB connector and insert it straight in.
- Insert an USB device while the unit is stopped, so the "USB device" screen is displayed. Select an item and press [OK] to switch to the USB-related operations (⇒ 28, 50, 51).

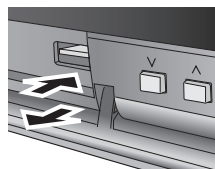

### Removing the USB memory

- Complete all USB-related operations and pull the USB memory straight out.
- If a USB memory being accessed is pulled out, then the data may be damaged.

## Disc care

### How to hold a disc

Do not touch the recorded surface.

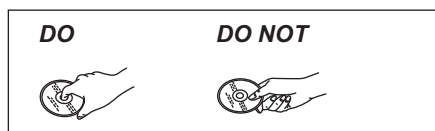

### If there is dirt or condensation on the disc

Wipe with a damp cloth and then wipe dry.



### Handling precautions

- Be careful about scratches and dirt.
- Do not attach labels or stickers to discs. (This may cause disc warping and un-balanced rotation, rendering it unusable.)
- Write on the label side of the disc only with a soft, oil-based felt pen. Do not use ballpoint pens or other hard writing implements.
- Do not use record cleaning sprays, benzine, thinner, static electricity prevention liquids or any other solvent.
- Do not use scratch-proof protectors or covers.
- Do not drop stack, or impact discs. Do not place objects on them.
- Do not use the following discs:
  - Discs with exposed adhesive from removed stickers or labels (rental discs, etc.).
  - Discs that are badly warped or cracked.
  - Irregularly shaped discs, such as heart shapes.

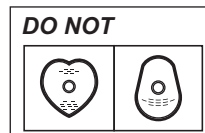

- Do not place in the following areas:
  - In direct sunlight.
  - In very dusty or humid areas.
  - Near a heater.
  - Locations susceptible to significant difference in temperature (condensation can occur).
  - Where static electricity or electromagnetic waves occur.
- To protect discs from scratches and dirt, return them to their cases when you are not using them.

**The manufacturer accepts no responsibility and offers no compensation for loss of recorded or edited material due to a problem with the unit or recordable media, and accepts no responsibility and offers no compensation for any subsequent damage caused by such loss.**

Examples of causes of such losses are

- A disc recorded and edited with this unit is played in a DVD Recorder or computer disc drive manufactured by another company.
- A disc used as described above and then played again in this unit.
- A disc recorded and edited with a DVD Recorder or computer disc drive manufactured by another company is played in this unit.





Refer to “Advanced playback” (⇒ 26) for detail information.

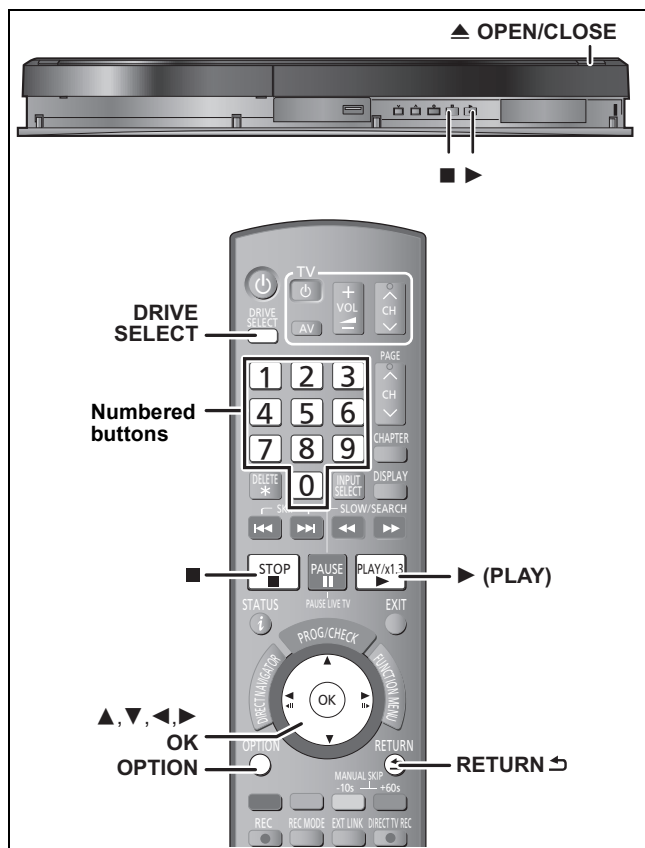

## Preparation

- Turn on the television and select the appropriate AV input to suit the connections to this unit.
- Turn on this unit.

### 1 Press [DRIVE SELECT] to select the HDD or DVD drive.

The HDD or DVD indicator lights up on the unit's display.

### 2 If you selected the DVD drive Press [▲ OPEN/CLOSE] on the main unit to open the tray and insert a disc.

- Press the button again to close the tray.

### 3 Press [▶] (PLAY).

**HDD RAM -R -R DL -RW(V) +R +R DL +RW -RW(VR)**

Play starts from the most recently recorded title.

**DVD-V VCD**

Play starts from the point specified by the disc.

**CD**

Play starts from the beginning of the disc.

#### Menu operation for other type of contents

- DivX (⇒ 28)
- MP3 (⇒ 29)
- Still pictures (JPEG) (⇒ 30)
- Music on HDD (⇒ 32)
- Music CD (⇒ 32)

## Note

- During recording, timer recording standby or EXT LINK standby, this unit cannot play discs that do not match the “TV System” (PAL/NTSC) (⇒ 63) setting. Set “TV System” to match the discs before playing them.
- When playing back a title recorded on HDD, ensure that you match the “TV System” (PAL/NTSC) setting to the recorded title (⇒ 63).
- Depending on the disc, it may take time for the menu screen, pictures, sound, etc. to start.
- The producer of the disc can control how discs are played. So you may not always be able to control play as described in these operating instructions. Read the disc's instructions carefully.

## ■ When a menu screen appears on the television

### DVD-V

Press [▲, ▼, ◀, ▶] to select the item and press [OK].

- Some items can also be selected using the numbered buttons.
- If you are instructed to press the “ENTER” button by the menu screen or the disc's instruction document, press [OK].

### VCD

Press the numbered buttons to select the item.

e.g., 5: [0] ⇒ [5] 15: [1] ⇒ [5]

## ● To return to the menu screen

### DVD-V

1 Press [OPTION].

2 Press [▲, ▼] to select “Top Menu” or “Menu” and press [OK].

### VCD

Press [RETURN ↵].

## Note

Discs continue to rotate while menus are displayed. Press [■] when you have finished playback to protect the unit's motor, your television screen and so on.

Refer to “Notes for recording” (⇒ 20) and “Advanced recording” (⇒ 21) for detail information.

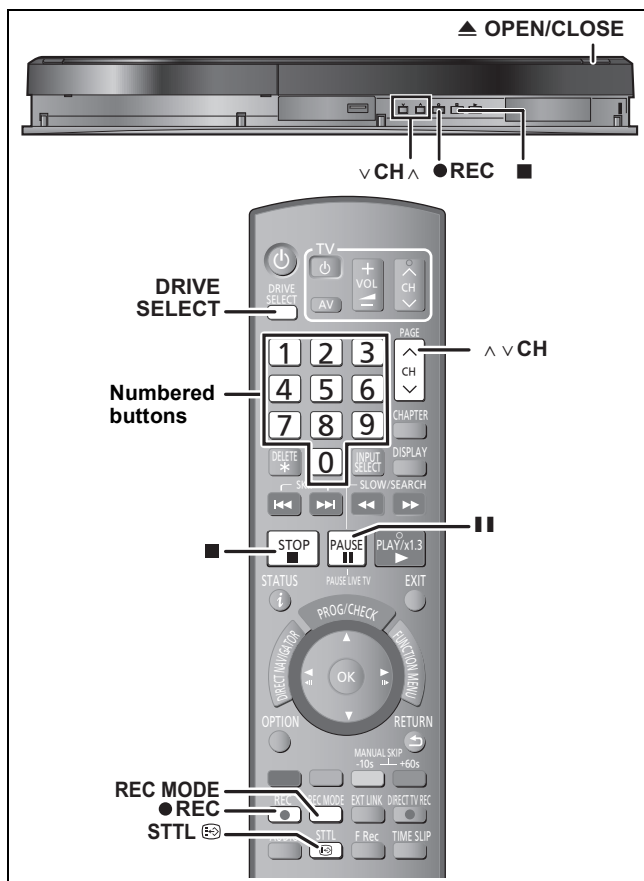

**HDD** **RAM** **-R** **-RW(V)** **+R** **+RW**

- From the start to the end of the recording is called one title.

### Preparation

- Turn on the television and select the appropriate AV input to suit the connections to this unit.
- Turn on this unit.

**1 Press [DRIVE SELECT] to select the HDD or DVD drive.**

The HDD or DVD indicator lights up on the unit's display.

**2 If you selected the DVD drive**

**Press [▲ OPEN/CLOSE] on the main unit to open the tray and insert a disc.**

- Press the button again to close the tray.

**3 Press [^ v CH] to select the channel.**

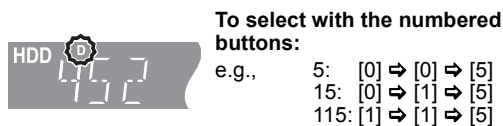

"D" means digital broadcasts.

**4 Press [REC MODE] to select the recording mode (XP, SP, LP or EP).**

- Recording modes and approximate recording times (⇒ 21) e.g.,

Recording Mode	
Rec Mode	Remain
XP	32:35
SP	65:11
LP	130:25
EP	260:04

- To record sound using LPCM (XP mode only): Set the "Audio Mode for XP Recording" to "LPCM" in the Setup menu (⇒ 62).

**5 Press [● REC] to start recording.**



Recording will take place on open space on the HDD or on disc. Data will not be overwritten.

- You cannot change the channel or recording mode during recording.
- You can record while the unit is in standby for timer recording. However, once the time for the timer recording to begin is reached, any recording taking place will stop and the timer recording will begin.

### To pause recording

Press [||].

Press again to restart recording.

You can also press [● REC] to restart. (Title is not split into separate titles.)

### To stop recording

Press [■].

#### Note

- **USB** It is not possible to record on a USB memory.
- Video will not be recorded to DVD-R discs which include JPEG images.
- **-R -RW(V) +R +RW** It takes about 30 seconds for the unit to complete recording management information after recording finishes.
- **RAM -RW(V) +R +RW** To use a new disc, formatting is necessary.
- When recording a digital radio broadcast or a digital broadcast that is not being received correctly, the digital channel information (⇒ 16) is also recorded and remains visible during playback.

**In order to play DVD-R, DVD-RW (DVD-Video format) and +R (recorded with this unit) on other DVD players, it is necessary to finalise them (⇒ 58).**

**In order to play +RW on other players, we recommend you to create a top menu. (⇒ 58)**

## When recording digital broadcast with subtitle or multiple audio

If a programme to record has subtitle or multiple audio, you can record with subtitle or selected audio.

### To record with subtitle

Before start recording, press [STTL] to show the subtitle.

If the programme has multiple subtitle, select the desired language (⇒ 16).

- Subtitle cannot be switched after recording.

### To record with the selected audio

Before start recording, select the desired language for audio (⇒ 16).

## To specify a time to stop recording—One Touch Recording

### During recording

**Press [● REC] on the main unit to select the recording time.**

- You can specify up to 4 hours later.
- The unit display changes as shown below.  
OFF 0:30 → OFF 1:00 → OFF 1:30 → OFF 2:00  
↑ Counter (cancel) ↓ OFF 4:00 ← OFF 3:00 ↓

- This does not work during timer recordings (⇒ 24) or while using Flexible Recording (⇒ 22).
- This unit is turned to standby mode when this unit is not operated for approximately 5 minutes after completing One Touch Recording, if "Auto Standby after OTR" is set to "On" in the Setup menu. (Default setting: "On") (⇒ 65)

### To cancel

Press [● REC] on the main unit several times until the counter appears.

- The time to stop recording is cancelled; however, recording continues.

### To stop recording

Press [■].

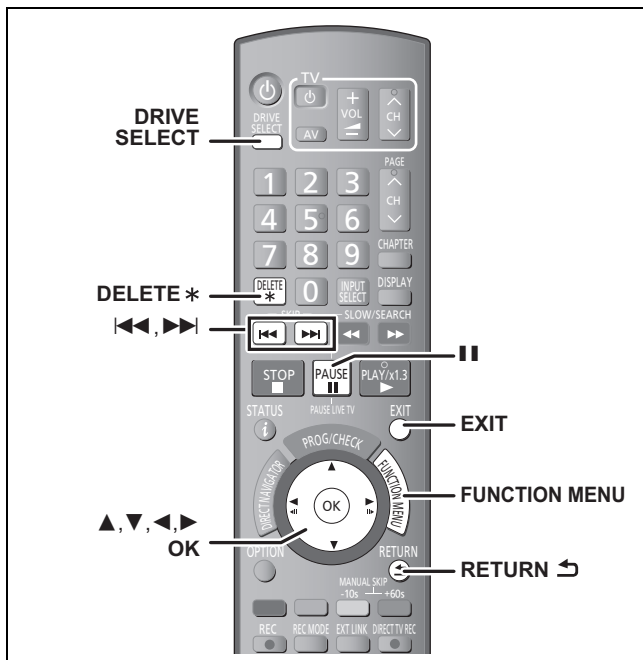

**HDD RAM -R -R DL -RW(V) +R +R DL +RW**  
 (You cannot delete items on finalised discs.)

- A title cannot be restored once it is deleted. Make certain before proceeding.
- You cannot delete while recording or copying.

### Preparation

- Press [DRIVE SELECT] to select the HDD or DVD drive.
- **RAM** Release protection (⇒ 56, Setting the protection).

### ■ Available disc space after deleting

- **HDD RAM** The space deleted becomes available for recording.

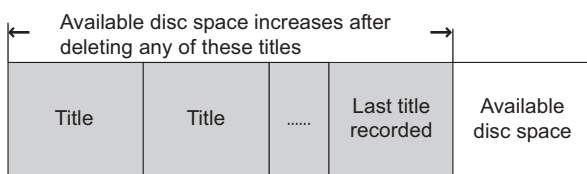

- **-RW(V) +RW** Available recording space increases only when the last recorded title is deleted.

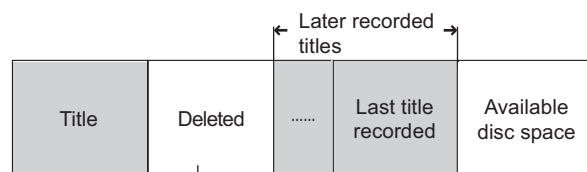
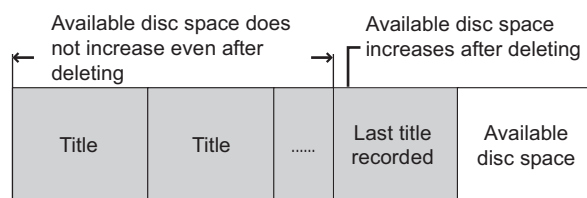

This space become available for recording after all the later recorded titles are deleted.

- **-R -R DL +R +R DL** Available space does not increase even after the contents are deleted.

## Using the DELETE Navigator to delete

- 1 While stopped  
Press [FUNCTION MENU].
- 2 Press [▲, ▼] to select “Delete” and press [OK].
- 3 Press [▲, ▼] to select “Video” and press [OK].

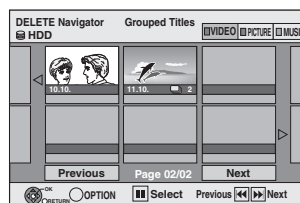

- 4 Press [▲, ▼, ◀, ▶] to select the title and press [II].

A check mark is displayed. Repeat this step until you select all necessary items.

- Press [II] again to cancel.

#### To show other pages

Press [◀, ▶] to show other pages.

You can confirm the titles, that you have selected using the option menu.

- Refer to option menu operations for the “Title View” (⇒ 36, step 4).

- 5 Press [OK].

- 6 Press [◀, ▶] to select “Delete” and press [OK].

The title is deleted.

#### To return to the previous screen







Press [RETURN ↵].

#### To exit the screen

Press [EXIT].

## Deleting during play

- 1 While playing  
Press [DELETE \*].
- 2 Press [◀, ▶] to select “Delete” and press [OK].  
The title is deleted.

<b>Selecting Audio for Recording</b>	<p><b>Broadcast in multi-channel sound:</b> You can select the audio language when receiving audio in multi channel broadcast ["Multi Audio" appears at the bottom of digital channel information display (⇒ 16)]. However, audio cannot be switched after recording.</p>  <p>Select the audio that you want to record in "DVB Multi Audio" in the on-screen menu (⇒ 55).</p>
<b>About the aspect when recording a programme</b>	<p><b>HDD RAM</b> (When "Rec for High Speed Copy" is set to "On") <b>-R -RW(V)</b> If "Aspect for Recording" in the Setup menu is set to "Automatic" (The default setting is "4:3" ⇒ 61), the programme will be recorded in the original aspect used when recording started (including when recording started at a commercial, etc.). If recorded with a different aspect, select the correct aspect ("16:9" or "4:3").</p> <p>However, in the following case, programme will be recorded in 4:3. ● <b>-R -RW(V)</b> Programme recorded using "EP" or "FR (recordings 5 hours or longer)" recording modes will be recorded in 4:3 aspect.</p> <p><b>HDD RAM</b> (When "Rec for High Speed Copy" is set to "Off") The programme will be recorded in the original aspect. <b>+R +RW</b> The programme will be recorded in 4:3 aspect.</p> 
<b>When you want to copy titles in high speed mode from the HDD to DVD-R, etc.</b>	<p><b>-R -R DL -RW(V) +R +R DL +RW</b> Set "Rec for High Speed Copy" to "On" before recording to the HDD. (The default setting is "On". ⇒ 61) You can copy titles in high speed mode (max. speed is 75X*); however, the audio and aspect settings (⇒ above) are necessary before recording to the HDD. * Depending on the disc, max. speed may vary.</p> <p style="text-align: center;">Record to the HDD  <b>HDD</b>  High speed copy to DVD-R, etc.</p> <p>In the following cases, high speed mode does not work. ● <b>+R +R DL +RW</b> Titles recorded in "EP" mode and "FR (recordings 5 hours or longer)" mode ● <b>+R +R DL +RW</b> Titles recorded in 16:9 aspect ● <b>-R -R DL -RW(V)</b> Titles recorded in 16:9 aspect using "EP" mode or "FR" (recordings 5 hours or longer) mode</p>
<b>When recording the "One time only recording" broadcasts</b>	<p>It is not possible to record the broadcasts that allow "One time only recording" onto DVD-R, DVD-RW, +R, +RW or 8 cm DVD-RAM discs. Use the HDD or CPRM (⇒ 78) compatible DVD-RAM.</p> <p><b>RAM</b> CPRM compatible discs only.</p>  <p>(○: Can do, -: Cannot do)</p> <ul style="list-style-type: none"> <li>● "One time only recording" titles can only be transferred from the HDD to CPRM compatible DVD-RAM (They are deleted from the HDD). They cannot be copied.</li> <li>● Even when copying to videotape the title may not be copied correctly because of the copy guard.</li> <li>● You cannot copy a Playlist (Video) created from "One time only recording" titles.</li> </ul>
<b>Playing the disc on other DVD players</b>	<p><b>-R -R DL -RW(V) +R +R DL</b> The disc must be finalised after recording or copying (⇒ 58). It is necessary to finalise DVD-R, etc. on this unit after recording or copying titles to them. You can then play them as a commercially sold DVD-Video. However, the discs become play-only and you can no longer record or copy.* * You can record and copy again if you format DVD-RW.</p> <p style="text-align: center;">Record to DVD-R, etc.  <b>Finalise</b>  Play on other DVD equipment</p> <p><b>+RW</b> If the disc failed to play on other equipment, we recommend you create top menu (⇒ 58).</p>
<b>Recording to DVD-R DL and +R DL</b>	<p>You cannot directly record to a DVD-R DL and +R DL disc on this unit. Record to the HDD and then copy to the disc.</p>

● It is not possible to record to both the HDD and the DVD drive simultaneously.

## Recording modes and approximate recording times

Depending on the content being recorded, the recording times may become shorter than indicated. (The times provided on this chart are an estimate.)

Recording Mode	HDD (160 GB)	DVD-RAM		DVD-R DVD-RW +R +RW (4.7 GB)	DVD-R DL <sup>*3</sup> (8.5 GB)	+R DL <sup>*3</sup> (8.5 GB)
		Single-sided (4.7 GB)	Double-sided <sup>*1</sup> (9.4 GB)			
<b>XP (High picture quality recording mode)</b>	35 hours	1 hour	2 hours	1 hour	1 hour 45 min.	1 hour 45 min.
<b>SP (Standard recording mode)</b>	70 hours	2 hours	4 hours	2 hours	3 hours 35 min.	3 hours 35 min.
<b>LP (Long recording mode)</b>	140 hours	4 hours	8 hours	4 hours	7 hours 10 min.	7 hours 10 min.
<b>EP (Extra long recording mode)<sup>*4</sup></b>	279 hours (209 hours <sup>*2</sup> )	8 hours (6 hours <sup>*2</sup> )	16 hours (12 hours <sup>*2</sup> )	8 hours (6 hours <sup>*2</sup> )	14 hours 20 min. (10 hours 45 min. <sup>*2</sup> )	
<b>FR (Flexible Recording Mode)<sup>*4</sup></b>	279 hours maximum	8 hours maximum	16 hours maximum	8 hours maximum	14 hours 20 min.	Approximately 9 hours with video quality equivalent to LP mode.

<sup>\*1</sup> It is not possible to record or play continuously from one side of a double sided disc to the other.

<sup>\*2</sup> When "Recording time in EP mode" is set to "EP ( 6 hours )" in the Setup menu (⇒ 61). The sound quality is better when using "EP ( 6 hours )" than when using "EP ( 8 hours )".

<sup>\*3</sup> You cannot record directly to DVD-R DL and +R DL discs with this unit. The table shows the recording time when copying.

**+R DL** You cannot copy in "EP" or "FR (recordings 5 hours or longer)" mode.

<sup>\*4</sup> When recording to the HDD in "EP" or "FR (recordings 5 hours or longer)" mode, you cannot perform high-speed copy to +R, +R DL or +RW discs.

● **RAM** When recording to DVD-RAM using "EP ( 8 hours )" mode, play may not be possible on DVD players that are compatible with DVD-RAM. Use "EP ( 6 hours )" mode if playback may be on other equipment.

**HDD**  
● You can record up to 499 titles on HDD. (When continuously recording for long durations, titles are automatically divided every 8 hours.)

**RAM -R -RW(V)**  
● You can record up to 99 titles on one disc.

**+R +RW**  
● You can record up to 49 titles on one disc.

### FR (Flexible Recording Mode)

You can set FR (Flexible Recording) mode when copying or programming timer recordings.

The unit automatically selects a recording rate between XP and EP ( 8 hours ) that will enable the recordings to fit in the remaining disc space with the best possible recording quality.

For example with a 90-minute recording to an unused DVD-RAM, the picture quality is adjusted to between "XP" and "SP".

● When recording to the HDD, picture quality is automatically adjusted to precisely fit a copied title on a 4.7 GB disc.

● All the recording modes from XP to EP appear in the display.

## When the format confirmation screen is displayed

**RAM -RW(V) +R +R DL +RW**

When you insert a new disc or a disc recorded on a computer or other equipment, a format confirmation screen is displayed. Format the disc to use it. However, all the recorded contents are deleted.

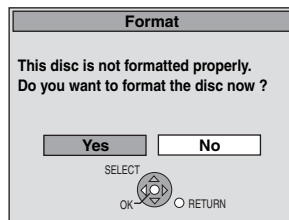

Press [**◀**, **▶**] to select "Yes" and press [OK].

### To format a disc

"Deleting all the contents—Format" (⇒ 57)

## When removing a recorded disc

**-R -R DL -RW(V) +R +R DL**

The following screen appears when you have not processed the disc for play on other equipment.

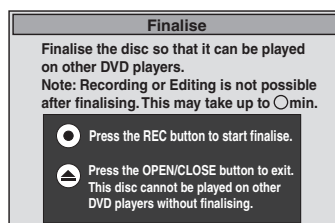

e.g. Disc recorded with Videos

### ■ To finalise the disc

Press [**●** REC] on the main unit.

● You cannot stop this process once you have started it.

● If you want to set the background, play menu select or provide a disc name, select "Top Menu" (⇒ 58), "Auto-Play Select" (⇒ 58) or "Disc Name" (⇒ 57) in "DVD Management" before finalising.

### ■ To open the tray without disc finalisation

Press [**▲** OPEN/CLOSE] on the main unit.

## Flexible Recording

(Recording that fits the remaining disc space)

**HDD** **RAM** **-R** **-RW(V)** **+R** **+RW**

The unit sets the best possible picture quality that fits the recording within the remaining disc space. The recording mode becomes FR mode.

### ■ Using “Flexible Rec” is convenient in these kinds of situations.

**RAM** **-R** **-RW(V)** **+R** **+RW**

- When the amount of free space on the disc makes selecting an appropriate recording mode difficult
- When you want to record a long programme with the best picture quality possible

**HDD**

- When you want to record a title to HDD so that it can then be copied to fit one 4.7 GB disc perfectly
- You do not need to edit the recorded title, or change the recording mode when copying, to fit the disc space.

e.g., Recording a 90-minute programme to disc

#### If you select XP mode, the programme will not fit one disc.



If you try to record a 90-minute programme in XP mode, only the first 60 minutes will fit on the disc and the 30-minute balance will not get recorded.

- Another disc is necessary.

#### If you select SP mode, the programme will fit one disc.



However there will be 30 minutes remaining disc space.

#### If you select “Flexible Rec” the programme will fit one disc perfectly.



■ Necessary space for recording

#### Preparation

- Select the channel or the external input to record.
- Press [DRIVE SELECT] to select the HDD or DVD drive.

### 1 While stopped Press [F Rec].

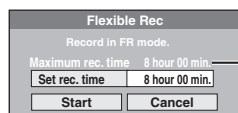

**Maximum recording time**  
This is the maximum recording time in EP ( 8 hours ) mode.

### 2 Press [◀, ▶] to select “hour” and “min.” and press [▲, ▼] to set the recording time.

- You can also set the recording time with the numbered buttons.
- You cannot record more than 8 hours.

### 3 When you want to start recording Press [▲, ▼, ▶, ◀] to select “Start” and press [OK].

**To exit the screen without recording** e.g., HDD  
Press [RETURN ↵].

**To stop recording partway**  
Press [■].

**To show the remaining time**  
Press [STATUS ⓘ].

Remaining time of recording

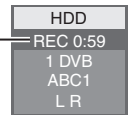

## Playing while you are recording

**HDD** **RAM**

### Playing from the beginning of the title you are recording—Chasing playback

#### Press [▶] (PLAY) during recording.

There is no sound output while searching forward or backward.

#### To stop play

Press [■].

#### To stop recording

2 seconds after play stops, press [■].

#### To stop timer recording

2 seconds after play stops

- 1 Press [■].
- 2 Press [◀, ▶] to select “Stop Recording” and press [OK].

### Playing a title previously recorded while recording—Simultaneous rec and play

- You can also change the drive and play while recording. Press [DRIVE SELECT].

### 1 Press [DIRECT NAVIGATOR] during recording.

### 2 Press [▲, ▼, ▶, ◀] to select a title and press [OK].

- There is no sound output while searching forward or backward.

#### To stop play

Press [■].

#### To exit the DIRECT NAVIGATOR screen

Press [DIRECT NAVIGATOR].

#### To stop recording

After play stops

- 1 Press [DIRECT NAVIGATOR] to exit screen.
- 2 Press [■].
- 3 If the recording stop confirmation screen is displayed, press [◀, ▶] to select “Yes” or “Stop Recording” and press [OK] to stop recording.

#### Note

“Chasing playback” and “Simultaneous rec and play” can only be used with programmes of the same encoding system (PAL/NTSC).

**HDD** **RAM** **-R** **-RW(V)** **+R** **+RW**

See also “Notes for recording” (⇒ 20).

## Making timer recordings on the television

(e.g., of digital broadcasts)

### HDD

To make a timer recording with your television, connect to a television with a Q Link function (⇒ 34) that you can use for setting timer recordings using a fully wired 21-pin Scart cable (⇒ 8).

- 1 Make timer programming on the TV.**
- 2 Turn off this unit.**

The start and end of recording is controlled by the TV.

- The titles are recorded to the HDD.

### To stop recording

Press [■].

### Note

- When this unit is in EXT LINK standby (“EXT-L” is shown on the unit’s display), recording from television does not start.
- Programmes are recorded as one title on this unit when the end time of the earlier timer recording and the start time of the later timer recording are close to each other.  
To divide the titles, go to “Divide Title” (⇒ 37).

## Recording from digital satellite receiver

### Preparation

- Connect a digital satellite receiver to this unit’s AV2 input terminals (⇒ 8).
- Set “AV2 Input” to match the connected equipment in the Setup menu (⇒ 64).
- When the output signal from the external equipment is NTSC, change the “TV System” to “NTSC” in the Setup menu (⇒ 63).
- Press [DRIVE SELECT] to select the HDD or DVD drive.

- 1 While stopped**  
**Press [INPUT SELECT] to select “AV2”.**
- 2 Press [REC MODE] to select the recording mode.**
- 3 Select the channel on the other equipment.**
- 4 Press [● REC].**  
Recording starts.

### To skip unwanted parts

Press [■] to pause recording. (Press again to restart recording.)

### To stop recording

Press [■].

### Note

- This unit cannot record NTSC signals to discs that already have PAL signal recordings. (However, both types of programmes can be recorded onto the HDD.)

## Linked timer recordings with external equipment (digital satellite receiver) — EXT LINK

To record programmes from digital satellite receiver using timer programming

### Preparation

- Make sure you connect the AV2 input terminal of this unit to the Scart terminal of a VCR or a digital satellite receiver with a 21-pin Scart cable (⇒ 67).
- Set “Ext Link” to match the connected equipment in the Setup menu (⇒ 64).
- Set “AV2 Input” to match the connected equipment in the Setup menu (⇒ 64).

- 1 Make timer programming on the external equipment.**
- 2 Press [DRIVE SELECT] to select the HDD or DVD drive.**  
If you selected the DVD drive, insert a disc (⇒ 15).
- 3 Press [EXT LINK].**

The unit turns off and “EXT-L” lights on the unit’s display to indicate timer recording standby has been activated.

### To cancel the external control

Press [EXT LINK] to stop recording or to cancel linked timer recording standby.

- In order to prevent accidental operation, press [EXT LINK] to cancel the setting after recording is finished.

### Note

- This function does not work when “TV System” is set to “NTSC” in the Setup menu (⇒ 63).
- This function does not work with some equipment. Refer to the equipment’s operating instructions.
- The beginnings of recordings may not be recorded correctly in some cases.
- Programmes are recorded as one title on this unit when the end time of the earlier timer recording and the start time of the later timer recording are close to each other.  
**HDD** **RAM** To divide the titles, go to “Divide Title” (⇒ 37).
- While the unit is in EXT LINK standby mode or recording, video picture is from the AV2 input terminal irrespective of “AV1 Output” setting (⇒ 63).
- During EXT LINK standby mode or recording, playback is only available from the drive performing the recording.
- When “EXT-L” lights on the unit’s display, Direct TV Recording is unavailable.
- While the unit is in EXT LINK standby mode or recording, most operations on this unit are prohibited ([▲ OPEN/CLOSE], [⏻/⏪] etc.). When you operate, press [EXT LINK] to cancel EXT LINK standby mode or recording (This unit turns on and “EXT-L” disappears.).

See also “Notes for recording” (⇒ 20).

Depending on the type of disc used for recording or the type of broadcast, there may be restrictions on the title you are trying to record.

**HDD** **RAM** **-R** **-RW(V)** **+R** **+RW**

• You can enter up to 32 programmes up to a month in advance.  
(Each daily or weekly programme is counted as one programme.)

**RAM** **-RW(V)** **+R** **+RW**

• To use a new disc, formatting is necessary.

### Note

You cannot switch subtitles during timer recording.

### Preparation

- Turn on the television and select the appropriate video input to suit the connections to this unit.
- If recording to DVD, insert a disc that you can use for recording (⇒ 11).
- Make sure that the clock settings are correct (⇒ 64).

## Manually programming timer recordings

### 1 Press [PROG/CHECK].

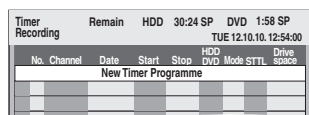

### 2 Press [▲, ▼] to select “New Timer Programme” and press [OK].

### 3 Press [◀, ▶] to move through the items and change the items with [▲, ▼].

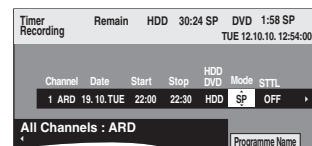

- When “Channel” is selected, you can press the “Blue” button to change the category [e.g., TV, Radio, Favourite (⇒ 59)] and then press [▲, ▼] to select the channel you want to record.
- Press and hold [▲, ▼] to alter the Start (Start time) and Stop (Finish time) in 30-minute increments.
- You can also set Channel (Programme position/TV Station Name), Date, Start (Start time), and Stop (Finish time) with the numbered buttons.
- **Date**
  - **Date:** Current date up to one month later minus one day
  - ↓ ↑
  - **Daily timer:** SUN-SAT → MON-SAT → MON-FRI
  - ↓ ↑
  - **Weekly timer:** SUN → --- → SAT

Titles recorded using the same daily or weekly timer are bundled and displayed as a “group” in the DIRECT NAVIGATOR screen (⇒ 27) except when using Auto Renewal Recording.

- You can also press [DRIVE SELECT] to select the recording drive.  
When the recording drive is “DVD” and there is not enough remaining space, recording automatically switches to the “HDD” (⇒ 25, Relief Recording).
- You can also press [REC MODE] to change the recording mode.
- **HDD RENEW (Auto Renewal Recording)** (⇒ 25)  
ON ↔ OFF
- **Programme Name**  
Press [◀, ▶] to select “Programme Name” and press [OK]. (⇒ 44, Entering text)
- **STTL (Subtitles)**  
AUTO ↔ OFF  
When the “Channel” column is set in AV1 or AV2, this setting is unavailable.

You can also press [STTL ] to switch “STTL” setting.

When there are multiple languages, select the subtitle (⇒ 60, DVB Preferred Language).

### 4 Press [OK].

The timer programme is stored and the timer icon is displayed.



“Ⓞ” lights on the unit’s display to indicate timer recording standby has been activated.

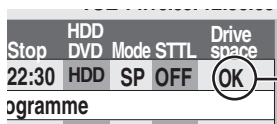

Check to make sure “OK” is displayed (⇒ below).

Repeat steps 2–4 to programme other recordings.  
Press [⏻] to turn the unit off.

## Check, change or delete a programme

- Even when the unit is turned off, you can display the timer recording list by pressing [PROG/CHECK].

### Press [PROG/CHECK].

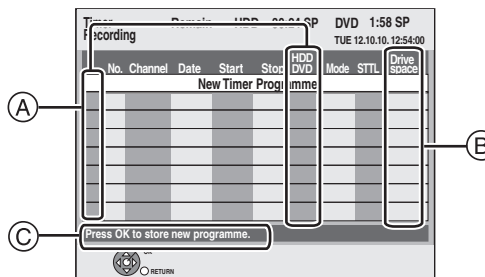

#### A Icons

- Ⓞ Timer recording standby is activated.
- This programme is currently recording.
- ⊖ Programmes are overlapped. Recording of the programme with the later start time starts when the earlier programme finishes recording.
- ⊘ You stopped a daily or weekly timer recording. The icon disappears the next time the timer programme starts recording.
- Ⓛ The disc was full so the programme failed to record.
- Ⓜ The programme was copy-protected so it was not recorded.
- ✗ The programme did not complete recording because the disc is dirty or some other reason.
- ↻ Timer programmes set to Auto Renewal Recording (⇒ 25).
- ↵ Titles that have been rerouted to the HDD (Displayed while recording.)

- HDD** Recording drive is set to HDD
- DVD** Recording drive is set to DVD

#### B Message displayed in the “Drive space” line

**OK:** Displayed if the recording can fit in the remaining space.

→ **(Date):** For recordings made daily or weekly, the display will show until when recordings can be made (up to a maximum of one month from the present time) based on the time remaining on the disc.

! : It may not be possible to record because:

- there is not enough space left.
- the number of possible titles has reached its maximum.
- programmes are overlapped.
- programmes are deactivated.

**Relief:** Timer programmes that will be relief recorded to the HDD.

#### C Channel name, programme name and other information are displayed.



## ■ To change a programme

Press [▲, ▼] to select the programme and press [OK]. (⇒ 24, Manually programming timer recordings, step 3)

## ■ To delete a programme

Press [▲, ▼] to select the programme and press [DELETE \*].

You can also delete a programme with the following steps

- 1 Press [▲, ▼] to select the programme and press [OPTION].
- 2 Press [▲, ▼] to select "Delete" and press [OK].

## ■ To release the unit from recording standby

Press [▲, ▼] to select the programme and press the "Red" button.

- The timer icon "⊙" disappears from the timer recording list.
- You cannot cancel timer recording standby mode as long as even one timer icon "⊙" remains in the timer recording list.
- Press the "Red" button again to activate timer recording standby.

## ■ To resolve overlapping

Press [▲, ▼] to select the programme with  and press [OK].

- Change or delete the overlapped programme.

## ■ To exit the timer recording list

Press [PROG/CHECK].

### Note

- Programmes that failed to record are deleted from the timer recording list at 4 a.m. two days later.

## To cancel recording when recording has already begun

- 1 While the unit is on  
Press [■].



- 2 Press [◀, ▶] to select "Stop Recording" and press [OK].

If you stop a timer recording, it will be cancelled. However, if you have set a weekly or daily timer recording, the recording will start from the next time the timer recording is set.

## Language for digital broadcast with multi-audio or multi-subtitle

In timer recording of digital broadcast with multi-audio or multi-subtitle, audio and subtitle language to be recorded will follow the setting of "DVB Preferred Language" in the Setup menu (⇒ 60).

## Relief Recording

When the recording drive is "DVD" and there is not enough remaining space, recording automatically switches to the "HDD". If there is no disc in the tray or the disc cannot be recorded on or when timer recording starts while copying, the recording drive will be altered to the HDD.

- The DIRECT NAVIGATOR shows which programmes were relief-recorded ("↔" is displayed.) (⇒ 27).
- If the time remaining on the HDD is insufficient, as much of the programme as possible will be recorded onto the HDD.

## Auto Renewal Recording

### HDD

If you record a programme onto HDD repeatedly everyday or every week using timer recording, the unit will record the new programme over the old one.

This function can be used only when daily or weekly timer recording is selected.

- 1 Press [PROG/CHECK].
- 2 Press [▲, ▼] to select the programme and press [OK].
- 3 Press [◀, ▶] to select "RENEW" column.
- 4 Press [▲, ▼] to select "ON" and press [OK].

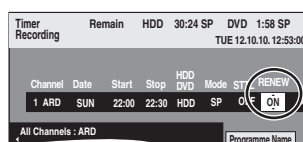

### Note

- If a programme set for Auto Renewal Recording is protected or while play back is taking place from the HDD, or while copying, the programme will not be overwritten. Instead the programme set for recording will be saved as a separate programme, and this programme will be the one to be overwritten when the next Auto Renewal Recording takes place.
- Playlist (Video) made from programmes that were set for Auto Renewal Recording are deleted along with auto renewal.
- When there is not enough space on the HDD, the programme may not be recorded completely.

## Notes on timer recording

- When a timer recording is set, DVDs that were recorded using a different TV System (PAL/NTSC) cannot be played unless the TV System is changed in the Setup menu (⇒ 63) or the timer recording has completed or has been cancelled.
- Timer recordings are activated regardless of whether the unit is turned on/off.
- Timer recordings begin when the set time is reached even when playing.
- Timer recordings do not begin while editing or copying in normal speed mode (⇒ 45).
- If the unit is turned on when timer recording begins, it remains turned on after recording finishes. It does not turn off automatically. You can turn the unit off during timer recording.
- When you programme successive timer recordings to start immediately one after the other, the unit cannot record the part at the beginning of the later programmes.

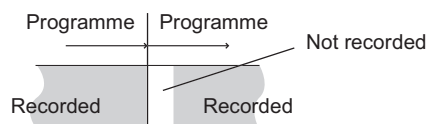

## Operation during play

• Depending on the media, some operations may not be possible.

<b>Stop</b>	<p><b>Press [■].</b> The stopped position is memorized.</p> <p><b>Resume play function</b> Press [▶] (PLAY) to restart from this position.</p> <p><b>Stopped position</b></p> <ul style="list-style-type: none"> <li>• If [■] is pressed several times, the position is cleared in some cases.</li> <li>• <b>(Except for HDD)</b> The position is cleared if the tray is opened.</li> <li>• <b>CD VCD</b> and <b>MP3/DivX</b> : The position is cleared if the unit is turned off.</li> </ul>
<b>Pause</b>	<p><b>Press [⏸].</b> Press [⏸] again or [▶] (PLAY) to restart play.</p>
<b>Search</b>	<p><b>Press [◀◀] or [▶▶].</b></p> <ul style="list-style-type: none"> <li>• The speed increases up to 5 steps. (+R +R DL +RW up to 3 steps)</li> <li>• Press [▶] (PLAY) to restart play.</li> <li>• Audio is heard during first level search forward.</li> <li>• <b>CD</b> and <b>MP3</b> : Audio is heard during all levels of search.</li> <li>• <b>DivX</b> : Audio is not heard during all levels of search.</li> </ul>
<b>Skip</b>	<p><b>During play or while paused, press [◀◀] or [▶▶].</b></p> <p>Skip to the title, chapter or track you want to play.</p> <ul style="list-style-type: none"> <li>• Each press increases the number of skips.</li> <li>• <b>DivX</b> : Press [◀◀] to return to the beginning of the title currently playing.</li> </ul>
<b>Starting from a selected title</b>	<p><b>Press the numbered buttons.</b> Play starts from the selected title, chapter or track.</p> <ul style="list-style-type: none"> <li>• <b>HDD</b> and <b>DivX</b> e.g., 5: [0] ⇒ [0] ⇒ [5] 15: [0] ⇒ [1] ⇒ [5]</li> <li>• <b>MP3</b> e.g., 5: [0] ⇒ [0] ⇒ [0] ⇒ [5] 15: [0] ⇒ [0] ⇒ [1] ⇒ [5]</li> <li>• Other discs Input a 2-digit number e.g., 5: [0] ⇒ [5] 15: [1] ⇒ [5]</li> </ul> <p>• This works only when stopped (the screen on the television) with some discs.</p> <p>• <b>VCD</b> (with playback control) If you press the numbered buttons while stopped (the above screen is displayed on the television) you can cancel PBC. (Elapsed play time appears on the unit's display.)</p>
<b>Quick View</b>	<p><b>Press and hold [▶] (PLAY) × 1.3).</b> Play speed is quicker than normal.</p> <ul style="list-style-type: none"> <li>• Press again to return to normal speed.</li> </ul>
<b>Slow-motion</b>	<p><b>While paused, press [◀◀] or [▶▶].</b> The speed increases up to 5 steps.</p> <ul style="list-style-type: none"> <li>• Press [▶] (PLAY) to restart play.</li> <li>• <b>VCD</b> Forward direction [▶▶] only.</li> <li>• The unit will pause if slow-motion play is continued for approximately 5 minutes (excluding <b>DVD-V VCD</b>).</li> </ul>



## Frame-by-frame

HDD RAM -R  
-R DL -RW(V)  
+R  
+R DL +RW  
DVD-V  
-RW(VR) VCD

## While paused, press [◀] (◀||) or [▶] (||▶).

Each press shows the next frame.

- Press and hold to change in succession forward or backward.
- Press [▶] (PLAY) to restart play.
- **VCD** Forward direction [▶] (||▶) only.

## Skipping the specified time (Time Slip)

HDD RAM

-R -R DL  
-RW(V) +R  
+R DL

(This function does not work with finalised discs.)

+RW -RW(VR)

## 1 Press [TIME SLIP]. 2 Press [▲, ▼] to select the time and press [OK].

Play skips the specified time.

- Each time you press [▲, ▼], the time increases [▲] or decreases [▼] by 1-minute intervals. (Press and hold for 10-minute intervals.)

This automatically disappears after approximately 5 seconds. To show the screen again press [TIME SLIP] again.

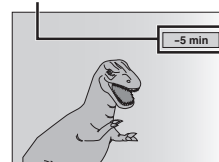

## Manual Skip

HDD RAM

-R -R DL  
-RW(V) +R  
+R DL

(This function does not work with finalised discs.)

+RW -RW(VR)

## 1-minute skip function:

### Press [MANUAL SKIP +60s].

Each time you press, play skips forward approximately 1 minute.

## 10-second skip back function:

### Press [MANUAL SKIP -10s].

Each time you press, play skips backward approximately 10 seconds.

## Create Chapter

(⇒ 36, Chapter)

HDD RAM

## Press [CHAPTER].

Chapters are divided at the point pressed.

- Press [◀◀, ▶▶] to skip to the start of a chapter.
- Chapters cannot be created during EXT LINK standby.

## Changing audio during play

### Press [AUDIO].

HDD RAM -RW(VR) VCD, DivX

LR→L→R

↑

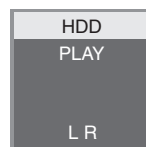

e.g., "L R" is selected

**DVD-V**

You can change the audio channel number each time you press the button. This allows you to change things like the soundtrack language (⇒ 54, Soundtrack).



e.g., English is selected.

### Note

You cannot change the audio type in the following cases.

- When a DVD-R, DVD-R DL, DVD-RW (DVD-Video format), +R, +R DL or +RW disc is in the disc tray while DVD drive is selected.
- When the recording mode is XP and "Audio Mode for XP Recording" is set to "LPCM" (⇒ 62).
- When "Rec for High Speed Copy" is set to "On" (The default setting is "On" ⇒ 61).

# Selecting recorded programmes (titles) to play—DIRECT NAVIGATOR

**HDD** **RAM** **-R** **-R DL** **-RW(V)** **+R** **+R DL** **+RW** **-RW(VR)**

You can quickly find the recorded titles and easily play them. You can also sort the titles or edit the Groups of titles.

## 1 Press [DIRECT NAVIGATOR].

**HDD** **RAM** When "VIDEO" is not selected, press the "Red" button to select "VIDEO".

## 2 Press [▲, ▼, ◀, ▶] to select the title and press [OK].

You can also select titles with the numbered buttons (All Titles screen only).

e.g., **HDD**  
5: [0] ⇒ [0] ⇒ [5]    15: [0] ⇒ [1] ⇒ [5]  
115: [1] ⇒ [1] ⇒ [5]

e.g., **RAM** **-R** **-R DL** **-RW(V)** **+R** **+R DL** **+RW** **-RW(VR)**  
5: [0] ⇒ [5]    15: [1] ⇒ [5]

### To show other pages

Press [▲, ▼, ◀, ▶] to select "Previous" or "Next" and press [OK].  
• You can also press [◀◀, ▶▶] to show other pages.

### To exit the screen

Press [DIRECT NAVIGATOR].

### DIRECT NAVIGATOR screen icons

●	Currently recording.
🔒	Title protected.
📄	Title that was not recorded due to recording protection (Digital broadcasts etc.)
×	Title cannot be played [When copying a title to the HDD, or when data is damaged etc.]
➡	Titles that have been rerouted to the HDD (⇒ 25, Relief Recording)
📄	Title with "One time only recording" restriction (⇒ 78, CPRM)
📄	Groups of titles ( <b>HDD</b> only)
▶	Title that was recorded but has not yet been played ( <b>HDD</b> only)
NTSC	Title recorded using a different encoding system from that of the TV system currently selected on the unit.
PAL	• Alter the "TV System" setting on this unit to suit (⇒ 63).

## Switching the DIRECT NAVIGATOR appearance

"Grouped Titles"/"All Titles" **HDD**  
"Table Display"/"Thumbnail Display"

- While the DIRECT NAVIGATOR screen is displayed Press [OPTION].
- Press [▲, ▼] to select the item and press [OK].  
e.g.,



### Grouped Titles screen

Two or more titles recorded in the Daily/weekly timer recording mode are bundled and displayed as one item.

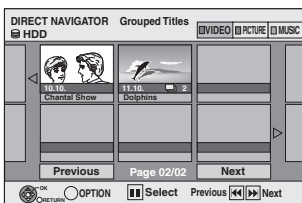

(in Thumbnail Display)

Select the item marked with and press [OK] to display the bundled titles.

### All Titles screen

Displays all titles.

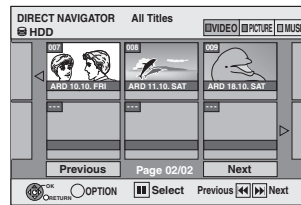

(in Thumbnail Display)

## To sort the titles for easy searching

**HDD** (All Titles screen in Table Display only)

This function is convenient when searching for one title to playback from many titles.

- Press [OPTION].
- Press [▲, ▼] to select "Sort" and press [OK].
- Press [▲, ▼] to select the item and press [OK].

If you select an item other than "No."

- The DIRECT NAVIGATOR screen will reappear after playback of the selected title has finished. (You cannot play titles continuously.)
- Skip and Time Slip will only function with the title currently being played back.
- If you exit the DIRECT NAVIGATOR screen, or switch to another DIRECT NAVIGATOR screen, the sort will be cancelled.

## To play grouped titles **HDD**

- Press [▲, ▼, ◀, ▶] to select the group and press [OK].
- Press [▲, ▼, ◀, ▶] to select the title and press [OK].

## To edit the group of titles **HDD**

**HDD** (Grouped Titles screen only)

- Press [▲, ▼, ◀, ▶] to select a title or a group and press [III].  
A check mark is displayed. Repeat this step until you select all necessary titles.  
• Press [III] to cancel.
- Press [OPTION].
- Press [▲, ▼] to select the option and press [OK].



### Create Group:

Press [◀, ▶] to select "Create" and press [OK].  
Selected titles are bundled to form a group.

### Release Grouping:

Press [◀, ▶] to select "Release" and press [OK].  
• When a group of titles has been selected, all the titles in the group are released.  
• When a title in a group has been selected, the title is released from the group.

### Regarding the group name

The name of the first title in the group is used as the group name.

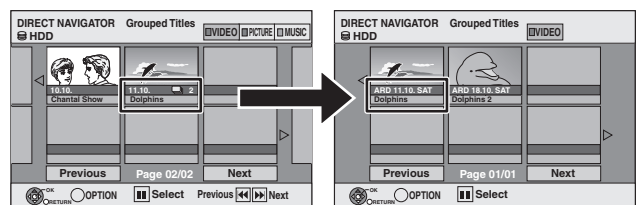

### To change the group name

- Press [▲, ▼, ◀, ▶] to select the group and press [OPTION].
- Press [▲, ▼] to select "Edit" and press [OK].
- Press [▲, ▼] to select "Enter Name" and press [OK].
- Enter the name. (⇒ 44, Entering text)

• Even if the group name is changed, the title names in the group will not be changed.

### Note

This function is only available for Videos and not available for music or still pictures.

## Showing the menu screen

**-R -R DL CD**

- 1 Insert the disc.
- 2 If the menu screen appears, press [▲, ▼] to select the item and press [OK].  
e.g., **CD**

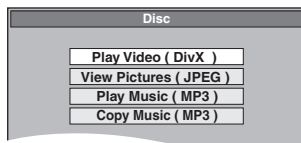

**USB**

- 1 Insert the USB memory.
- 2 Press [▲, ▼] to select a file type and press [OK].  
e.g.

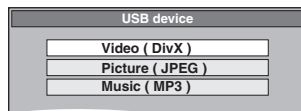

- 3 If the menu screen appears, press [▲, ▼] to select the item and press [OK].  
e.g., Picture

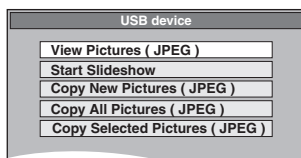

## Showing the menu with FUNCTION MENU Display

e.g. selecting a file to play

- 1 Press [RETURN ↵] several times to exit the menu.
- 2 Press [FUNCTION MENU].
- 3 **-R -R DL CD**

- ① Press [▲, ▼] to select "Playback" and press [OK].
- ② Press [▲, ▼] to select file type and press [OK].

**USB**

- ① Press [▲, ▼] to select "Drive Select" and press [OK].
- ② Press [▲, ▼] to select "USB" and press [OK].
- ③ Press [▲, ▼] to select file type and press [OK].
- ④ Press [▲, ▼] to select the item ("Play Video ( DivX )", "View Pictures ( JPEG )" or "Play Music ( MP3 )") and press [OK].

## Playing DivX video contents

**-R -R DL CD USB**

### ABOUT DIVX VIDEO:

DivX® is a digital video format created by DivX, Inc. This is an official DivX Certified device that plays DivX video. Visit [www.divx.com](http://www.divx.com) for more information and software tools to convert your files into DivX video.

You can play DivX video contents recorded with a computer onto DVD-R, DVD-R DL, CD-R/CD-RW and USB memory.

## 1 Show DivX Menu screen.

(⇒ left, Showing the menu screen)

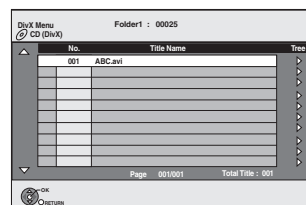

: Resume play function  
(⇒ 26)

- Files are treated as titles.
- Press [▶] (PLAY) if the DivX Menu screen is not displayed.

## 2 Press [▲, ▼] to select the title and press [OK].

Play starts on the selected title.

- You can also select the title with the numbered buttons.

e.g., 5: [0] ⇒ [0] ⇒ [5]  
15: [0] ⇒ [1] ⇒ [5]

### To stop playing

Press [■].

### To show other pages

Press [◀, ▶].

### To exit the screen

Press [DIRECT NAVIGATOR].

### Note

- Picture sizes set at the recording time may prevent the unit from showing pictures in the adequate aspect. You may be able to adjust the aspect through the TV.
- Successive play is not possible.
- Playback is not possible if recording is performed on the HDD drive or the DVD drive.

## Using the tree screen to find a folder

### 1 While the file list is displayed

Press [▶] while a title is highlighted to display the tree screen.

F: Selected folder no./Total folder no. including DivX title.

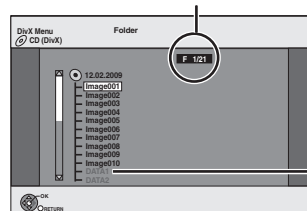

You cannot select folders that contain no compatible files.

### 2 Press [▲, ▼] to select a folder and press [OK].

The file list for the folder appears.

### To return to the previous screen

Press [RETURN ↵].

## Regarding DivX VOD content

**-R -R DL CD**

### ABOUT DIVX VIDEO-ON-DEMAND:

This DivX Certified® device must be registered in order to play DivX Video-on-Demand (VOD) content.

To generate the registration code, locate the DivX VOD section in the device setup menu.

Go to vod.divx.com with this code to complete the registration process and learn more about DivX VOD.

### Display the unit's registration code.

(⇒ 65, "DivX Registration" in "Others" tab)

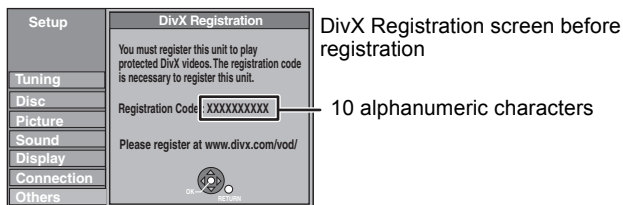

DivX Registration screen before registration

- After playing DivX VOD content for first time, the registration code is not displayed.
- If you purchase DivX VOD content using a registration code different from this unit's code, you will not be able to play this content.

### Cancel the unit's registration

(⇒ 65, DivX Registration)

Press [◀, ▶] to select "Yes" in "DivX Registration".

Use the deregistration code to cancel the registration in www.divx.com.

### Regarding DivX content that can only be played a set number of times

Some DivX VOD contents can only be played a set number of times. When you play this content, the number of times already played and initially playable number of times is displayed.

- The remaining number of plays decreases each time a programme is played. However, when playing from the point where play was previously stopped, the remaining number of plays does not decrease due to the resume play function.

## Playing Music files

**-R -R DL CD USB**

You can play MP3 files recorded with a computer onto a DVD-R, DVD-R DL, CD-R/CD-RW and USB memory.

- You cannot play MP3 files on the USB memory while recording or copying.

### 1 Show MP3 Menu screen.

(⇒ 28, Showing the menu screen)

G: Group No.  
T: Track No. in the group  
**TOTAL:**  
Track No./Total tracks in all groups

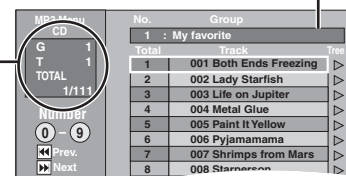

Selected group

- Files are treated as tracks and folders are treated as groups.

### 2 Press [▲, ▼] to select the track and press [OK].

Play starts on the selected track.

- "C" indicates the track currently playing.

- You can also select the track with the numbered buttons.

e.g., 5: [0] ⇒ [0] ⇒ [0] ⇒ [5]  
15: [0] ⇒ [0] ⇒ [1] ⇒ [5]

### To stop playing

Press [■].

### To show other pages

Press [◀◀, ▶▶].

### To exit the screen

Press [DIRECT NAVIGATOR].

## Using the tree screen to find a group

### 1 While the file list is displayed

Press [▶] while a track is highlighted to display the tree screen.

### Selected group No. /Total groups

If the group has no track, "--" is displayed as group number.

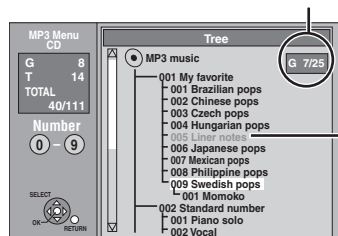

You cannot select groups that contain no compatible files.

### 2 Press [▲, ▼, ◀, ▶] to select a group and press [OK].

The file list for the group appears.

### To return to the previous screen

Press [RETURN ↵].

## Playing still pictures

HDD RAM -R -R DL CD USB

- You cannot play still pictures while recording or copying.

### 1 Show Album View screen.

-R -R DL CD USB

(⇒ 28, Showing the menu screen)

HDD RAM

While stopped

- Press [DRIVE SELECT] to select the drive.
- Press [DIRECT NAVIGATOR].  
When "PICTURE" is not selected, press the "Green" button to select "PICTURE".

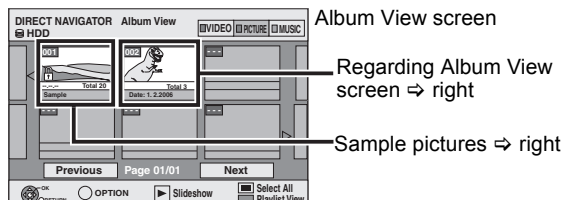

DIRECT NAVIGATOR screen icons

- Picture and folder protected
- Album that has not yet been viewed (HDD RAM)

To show other pages

Press [▲, ▼, ◀, ▶] to select "Previous" or "Next" and press [OK].

- You can also press [◀◀, ▶▶] to show other pages.

### 2 Press [▲, ▼, ◀, ▶] to select the album and press [OK].

You can also select album with the numbered buttons.  
e.g.,

5: [0] ⇒ [0] ⇒ [5]

15: [0] ⇒ [1] ⇒ [5]

115: [1] ⇒ [1] ⇒ [5]

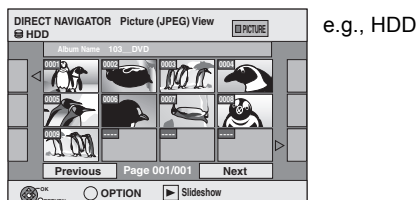

### 3 Press [▲, ▼, ◀, ▶] to select the still picture and press [OK].

You can also select still pictures with the numbered buttons.  
e.g.,

5: [0] ⇒ [0] ⇒ [0] ⇒ [5]      115: [0] ⇒ [1] ⇒ [1] ⇒ [5]

15: [0] ⇒ [0] ⇒ [1] ⇒ [5]      1115: [1] ⇒ [1] ⇒ [1] ⇒ [5]

- Press [◀, ▶] to display the previous or next still picture.
- Useful functions during still picture play (⇒ 31)

To return to the Album View screen or Picture (JPEG) View screen

Press [RETURN ⇩].

To exit the screen

Press [DIRECT NAVIGATOR].

### ■ Regarding Album View screen

Still pictures copied from USB memories are grouped by the shooting date in the HDD or DVD-RAM.

You can arrange these still pictures and create an album (⇒ 40).

HDD RAM

Grouped by date



Number of pictures/Shooting date

HDD RAM -R -R DL CD USB

Album

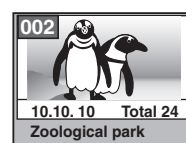

Shooting date/Number of pictures/  
Album name

- Depending on the digital camera, the editing software on the PC etc., the information about the recording date may not be displayed. In this case, the date will appear as [--.--.--].

Note

Sample pictures

- Sample JPEG pictures are pre-installed on HDD of this unit. You can play them back or start slideshow (⇒ below) with them. If you want to delete sample pictures, perform "Cancel Protection" and then delete them. (⇒ 40)

## Start Slideshow

HDD RAM -R -R DL CD USB

You can display still pictures one by one at a constant interval with favourite music.

- While the Album View (Playlist (Picture)) screen is displayed Press [▲, ▼, ◀, ▶] to select the album.

### 2 Press [▶] (PLAY).

You can also start Slideshow by pressing [OPTION] and press [▲, ▼] to select "Start Slideshow" and then press [OK].

To select multiple albums for starting Slideshow:

- Press [▲, ▼, ◀, ▶] to select the album.
- Press [■].  
A check mark appears.  
• Press [■] again to cancel the selection.
- Repeat steps ①-② until you select all necessary albums.
- Perform step 2.

To select all albums for starting Slideshow:

- Press [■] in step 1.
- Press [◀, ▶] to select "Yes" and press [OK].
- Perform step 2.

USB

To start Slideshow on the menu screen:

- Insert the USB memory.  
The menu is automatically displayed. (⇒ 28)
- Press [▲, ▼] to select "Start Slideshow", and press [OK].

Note

- Sample Music is selected for default Background Music, which is played with Slideshow. Refer to "Slideshow Settings" to turn off or change the Background Music. (⇒ 31)

## Useful functions during still picture play

### Slideshow Settings

While the Album View (Playlist (Picture)) screen is displayed (⇒ 30)

- 1 Press [OPTION].
- 2 Press [▲, ▼] to select “Slideshow Settings” and press [OK].
- 3 Press [▲, ▼] to select “Picture Settings” or “Background Music Settings” and press [OK].
- 4 Press [▲, ▼] to select the item and press [◀, ▶] to select the setting.



After finishing settings, press [▲, ▼, ▶, ◀] to select “Set” and press [OK].

#### Picture Settings

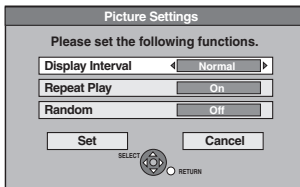

- Display Interval: Selects the desired interval. (“Normal”, “Long” or “Short”)
- Repeat Play: Selects “On” to play pictures in the selected album repeatedly.
- Random: Selects “On” to play pictures in the selected album at random.

#### Background Music Settings

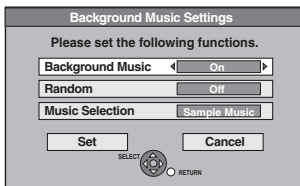

- Background Music: Selects “On” to play Slideshow with Background Music. Selects “Off” to play Slideshow without Background Music.
- Random: Selects “On” to play Background Music at random.
- Music Selection:
- ① Press [▲, ▼] to select “Music Selection” and press [OK].
  - ② Press [▲, ▼] to select the storage location of Background Music and press [OK].
    - “Sample Music” is Background Music pre-installed on HDD.
  - ③ Press [▲, ▼] to select an album for Background Music and press [OK] when selecting other than “Sample Music”.

#### Note

- Music albums on HDD, a disc and a USB memory can be used as the Slideshow Background Music. However, when selecting still images on a disc or a USB memory for the slideshow, music albums on the same media cannot be used as the Background Music. (Even if a music album on the same media is selected, the music is not played.)
- “Sample Music” cannot be deleted or changed to other files.
- “Music Selection” setting turns back to “Sample Music” when removing media on which specified Background Music is recorded or deleting specified Background Music files.
- DTS-CD cannot be played back as Slideshow Background Music.
- “Rotate RIGHT/Rotate LEFT” or “Zoom in/Zoom out” does not work during Slideshow.

### Rotate RIGHT/Rotate LEFT

While playing

- 1 Press [OPTION].
- 2 Press [▲, ▼] to select “Rotate RIGHT” or “Rotate LEFT” and press [OK].

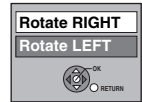

- Rotation information will not be stored.
  - [R] [R DL] [CD] [USB] Still pictures
  - When disc or album is protected
  - When played on other equipment
  - When copying pictures
  - When changing date

### Zoom in/Zoom out

While playing

- 1 Press [OPTION].
- 2 Press [▲, ▼] to select “Zoom in” and press [OK].

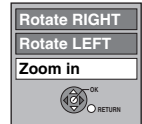

- To return the picture to its original size, press [▲, ▼] to select “Zoom out” in step 2 and press [OK].
- When zooming in, the picture may be cut off.
- The enlargement information will not be stored.
- The “Zoom in/Zoom out” function is only available for still pictures smaller than 640 × 480 pixels.

### Properties

While playing

Press [STATUS ⓘ] twice.

e.g., HDD



Shooting date

To exit the picture properties screen

Press [STATUS ⓘ].

## To play music CD

### Preparation

Press [DRIVE SELECT] to select the DVD drive.

### 1 Insert a music CD.

The menu is automatically displayed.

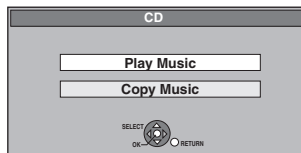

### 2 Press [▲, ▼] to select “Play Music” and press [OK].

The music CD starts playing back.

You can also select the track with the numbered buttons.

e.g.,

5: [0] ⇒ [5]

15: [1] ⇒ [5]

## To play music recorded on HDD

### Copying music to HDD (⇒ 52)

### Preparation

Press [DRIVE SELECT] to select the HDD drive

### 1 Press [DIRECT NAVIGATOR].

When “MUSIC” is not selected, press the “Yellow” button to select “MUSIC”.

### 2 Press [▲, ▼] to select the album and press [OK].

You can also select the album with the numbered buttons.

e.g.,

5: [0] ⇒ [0] ⇒ [5]      115: [1] ⇒ [1] ⇒ [5]

15: [0] ⇒ [1] ⇒ [5]

### 3 Press [▲, ▼] to select the track and press [OK].

You can also select the track with the numbered buttons.

e.g.,

5: [0] ⇒ [0] ⇒ [0] ⇒ [5]      115: [0] ⇒ [1] ⇒ [1] ⇒ [5]

15: [0] ⇒ [0] ⇒ [1] ⇒ [5]      1115: [1] ⇒ [1] ⇒ [1] ⇒ [5]

### To return to the previous screen

Press [RETURN ↵].

### To exit the screen

Press [DIRECT NAVIGATOR].

### Note

- You cannot play music tracks on HDD while recording or copying.

## Useful functions during music play

### Operations during play

Stop	<p><b>Press [■].</b> The stopped position is memorized. Press [▶] (PLAY) to restart from this position. • If [■] is pressed several times, the position is cleared.</p>
Pause	<p><b>Press [⏸].</b> Press [⏸] again or [▶] (PLAY) to restart play.</p>
Search	<p><b>Press [◀◀] or [▶▶].</b> The speed increases up to 5 steps. Press [▶] (PLAY) to restart play.</p>
Skip	<p><b>During play or while paused, press [◀◀] or [▶▶].</b> Skip to the track you want to play. • Each press increases the number of skips.</p>

### Repeat Play

**HDD**

You can select the item which you want to repeat.

While playing

- 1 Press [OPTION].
  - 2 Press [▲, ▼] to select “Repeat Play Setting” and press [OK].
  - 3 Press [▲, ▼] to select the item and press [OK].
- Select “Off” to cancel repeat play.

### Sort

**HDD**

You can change the order of the Album View alphabetically.

While Album View screen is displayed

- 1 Press [OPTION].
- 2 Press [▲, ▼] to select “Sort” and press [OK].
- 3 Press [▲, ▼] to select “Album Name” and press [OK].

### To cancel the sorted screen

Press [▲, ▼] to select “No.” and press [OK].

### Properties

**HDD**

While Track View screen is displayed

- 1 Press [OPTION].
  - 2 Press [▲, ▼] to select “Properties” and press [OK].
- To exit the Properties screen, press [OK].



## FUNCTION MENU Display

By using the FUNCTION MENU you may access the main functions quickly and easily. If "FUNCTION MENU Display" is set to "On" in the Setup menu, FUNCTION MENU automatically appears when you turn the power on. (⇒ 62)

### 1 Press [FUNCTION MENU].

Functions displayed depend on the selected drive or type of disc.

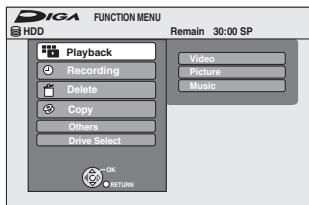

### 2 Press [▲, ▼] to select a function and press [OK].

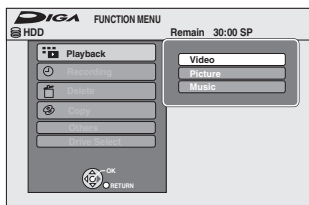

- If you press [RETURN ↵], you can return to the previous screen.

### 3 Press [▲, ▼] to select an item and press [OK].

- Refer to "Easy access to various functions — FUNCTION MENU Display" about each function. (⇒ 7)

#### To exit the FUNCTION MENU

Press [FUNCTION MENU].

## To pause the TV programme you are watching—Pause Live TV

You can pause the TV programme you are watching using this unit's tuner and resume later by temporarily saving it on the HDD. This is useful when you have to briefly stop watching TV to run an errand. If you stop the Pause Live TV function, then the TV programme temporarily saved on the HDD will be deleted.

- 1 Turn on the television and select the appropriate AV input to suit the connections to this unit.
- 2 Turn on this unit and press [^ v CH] to select the channel.
- 3 When you want to pause the TV programme Press [PAUSE LIVE TV].

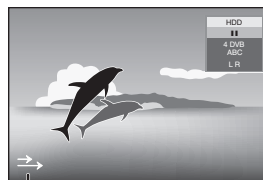

This icon indicates that Pause Live TV is working. You can turn off this icon (⇒ 62, Pause Live TV Icon).

### 4 When you want to resume Press [▶] (PLAY).

- The programme is saved on the HDD in SP recording mode (⇒ 21) regardless of the recording mode and the drive selected before starting saving.
- At least 1 hour up to 8 hours of TV programmes can be temporarily saved on the HDD. (This may vary depending on the HDD free space.)

#### Operation during Pause Live TV

Search	Press [◀, ▶].
Pause	Press [  ]. • Press [▶] (PLAY) to restart.
Quick View	Press and hold [▶] (PLAY/×1.3). • Press again to return to the normal speed.
Slow-motion	While paused, press [◀◀] or [▶▶]. The speed increases up to 5 steps. • Press [▶] (PLAY) to restart play.
Stop Pause Live TV	1 Press [■]. 2 Press [◀, ▶] to select "Yes" and press [OK].

#### Note

- The Pause Live TV function automatically stops when a timer recording starts.
- The Pause Live TV function does not work
  - when the clock is not set
  - while recording
  - while timer recording
  - while EXT LINK recording, etc.
- Audio or Subtitle cannot be switched during resume play.
- The first 30 minutes is deleted every 30 minutes after the HDD is full or the saving lasts 8 hours.
- The Pause Live TV function stops automatically 24 hours after started.
- "DVB Multi Audio" and "DVB Subtitles" of on-screen menu cannot be switched during Pause Live TV.

You can enjoy linked operations with the TV and receiver by using “HDAVI Control” or Q Link.

## What is VIERA Link “HDAVI Control”?

VIERA Link “HDAVI Control” is a convenient function that offers linked operations of this unit, and a Panasonic TV (VIERA) or receiver under “HDAVI Control”. You can use this function by connecting the equipment with the HDMI cable. See the operating instructions for connected equipment for operational details.

- VIERA Link “HDAVI Control”, based on the control functions provided by HDMI which is an industry standard known as HDMI CEC (Consumer Electronics Control), is a unique function that we have developed and added. As such, its operation with other manufacturers’ equipment that supports HDMI CEC cannot be guaranteed.

- **This unit supports “HDAVI Control 5” function.**

“HDAVI Control 5” is the newest standard (current as of December, 2009) for Panasonic’s HDAVI Control compatible equipment. This standard is compatible with Panasonic’s conventional HDAVI equipment.

- Please refer to individual manuals for other manufacturers’ equipment supporting VIERA Link function.

### Preparation

- 1 Connect this unit to your TV using an HDMI cable and a fully wired 21-pin Scart cable (⇒ 9), or to your receiver using an HDMI cable (⇒ 9).
- 2 Set “VIERA Link” to “On” (⇒ 63). (The default setting is “On”.)

- 3 Set the “HDAVI Control” operations on the connected equipment (e.g., TV).

- **Set the input channel on VIERA to suit the terminal to be used as “HDAVI Control”.**

- 4 Turn on all “HDAVI Control” compatible equipment and select this unit’s input channel on the connected TV so that the “HDAVI Control” function works properly.

**Also when the connection or settings are changed, repeat this procedure.**

## What is Q Link?

Q Link is a convenient function that offers linked operations of this unit and a Panasonic TV. You can use this function by connecting the equipment with a fully wired 21-pin Scart cable.

### Preparation

- Connect this unit to your TV with a fully wired 21-pin Scart cable (⇒ 8).

### For your reference

The following systems from other manufacturers have similar function to Q Link from Panasonic.

For details, refer to your television’s operating instructions or consult your dealer.

- Q Link (registered trademark of Panasonic)
- DATA LOGIC (registered trademark of Metz)
- Easy Link (registered trademark of Philips)
- Megalogic (registered trademark of Grundig)
- SMARTLINK (registered trademark of Sony)

## What you can do with “HDAVI Control” and Q Link

**VIERA Link** **Q Link**

### Download from the TV<sup>※1</sup>

When you connect the unit to a TV for the first time, the station list data etc. are automatically copied from the TV to the unit and the TV stations are assigned to the programme positions on the unit in the same order as on the TV (⇒ 10).

### Easy playback

When the TV is on and the following operations are performed, the TV’s input will automatically switch to HDMI input mode (**VIERA Link**) or AV input mode (**Q Link**) and the TV displays the corresponding action. (Picture or sound may not be available for the first few seconds.)

Press **[FUNCTION MENU]**<sup>※2</sup>, **[▶]** (**PLAY**)<sup>※3</sup>, **[DIRECT NAVIGATOR]**, **[PROG/CHECK]** etc.

### Power on link

When the TV is off and the following operations are performed, the TV will automatically turn on and displays the corresponding action. (Picture or sound may not be available for the first few seconds.)

Press **[FUNCTION MENU]**<sup>※2</sup>, **[▶]** (**PLAY**)<sup>※3</sup>, **[DIRECT NAVIGATOR]**, **[PROG/CHECK]** etc.

- **DVD-V** **CD** **VCD** **SVCD** and **MP3**

The TV is automatically turned on when you insert the discs.

### Power off link

When you set the TV to standby mode, the unit is also automatically set to standby mode. The unit is automatically set to standby mode even if the FUNCTION MENU etc. is displayed during playback or when the unit set to a timer recording.

Even if the TV is set to standby mode, the unit will not be set to standby mode at the same time when recording, copying, finalising etc.

- When this unit is connected to an “HDAVI Control” compatible Panasonic receiver with an HDMI cable, the receiver will also turn off.

### Direct TV Recording<sup>※1</sup>

This function allows you to immediately start recording the programme that you are viewing on the TV.

- **Depending on the TV type connected with this unit, this function may not work.**

**Press and hold [● DIRECT TV REC] for 1 second.**

Recording starts.

- The titles are recorded to the HDD.

#### To stop recording

Press **[■]**.

- If you switch TV channels while using Direct TV Recording, the Direct TV Recording may stop.
- When “EXT-L” lights on the unit’s display (⇒ 23), Direct TV Recording is unavailable.

<sup>※1</sup> **VIERA Link** This function is available with the TV that supports “HDAVI Control 3” or later.

<sup>※2</sup> This button is available only when this unit is on.

<sup>※3</sup> When this button is pressed, the playback image is not immediately displayed on the screen and it may not be possible to watch the contents from where playback started.

In this case, press **[◀◀]** or **[◀◀]** to go back to where playback started.

### Note

- These functions may not work normally depending on the equipment condition.
- About “HDAVI Control” function, read the manual of the connected equipment (e.g., TV) too.

## Easy control only with VIERA remote control

### VIERA Link

If you connect this unit to the TV that supports “HDAVI Control 2” or later with an HDMI cable, you can enjoy using more convenient functions. You can operate this unit using buttons on the TV remote control.

The buttons that you can use for this unit vary depending on the TV. For details, refer to the operating instructions of the TV.

Use the remote control supplied with this unit if you cannot operate this unit using buttons on the TV remote control.

- The operation of this unit may be interrupted when you press incompatible buttons on the TV remote control.
- The TV displays the TV tuner’s picture when the linked operation is finished.

## Using the FUNCTION MENU to operate this unit<sup>\*1</sup>

Refer to the TV operating instructions for operating the TV.

### 1 Display this unit’s “FUNCTION MENU” using the TV remote control.

- If this unit is set to standby mode, it will automatically turn on.

### 2 Select the item you want to operate with the TV remote control, and press [OK].

- About the FUNCTION MENU Display (⇒ 7, 33, 62).

## Pause live TV programme<sup>\*2</sup>

You can pause the TV programme you are watching and resume later by temporarily saving it on the HDD. This is useful when you have to briefly stop watching TV to run an errand.

If you stop the Pause Live TV function, then the TV programme temporarily saved on the HDD will be deleted.

Refer to the TV operating instructions for operating the TV.

### 1 When you want to pause the TV programme

#### Turn on the “Pause Live TV” function using the TV remote control.

- This unit turns on automatically.

### 2 When you want to resume

#### Display the Control Panel (⇒ below) and press [OK].

- The TV programme resumes.

#### To stop Pause Live TV

- ① Press [▼] while the Control Panel is displayed.
- ② Press [◀, ▶] to select “Yes” and press [OK].

(⇒ 33, To pause the TV programme you are watching—Pause Live TV)

## Using the OPTION menu window to operate this unit<sup>\*1</sup>

By using the TV remote control, you can play discs using the “Control Panel” (⇒ below) and display the Top Menu for DVD-Video.

### 1 Press [OPTION].

e.g.,



#### Note

You cannot use the OPTION menu while the Top Menu for DVD-Video is displayed and while DVD-Video is being copied.

### 2 Select an item then press [OK].

Control Panel	Control Panel is displayed (⇒ below).
FUNCTION MENU	FUNCTION MENU is displayed (⇒ above).
Top Menu <b>DVD-V</b>	Top menu is displayed (⇒ 17).
Menu <b>DVD-V</b>	Menu is displayed (⇒ 17).
Standby Settings	“Standby Settings” screen is displayed (⇒ 65).
Drive Select	Select the HDD or DVD drive
Slideshow	“Album View” screen is displayed (⇒ 30).
Rotate RIGHT (JPEG) Rotate LEFT (JPEG)	Rotate the still picture (⇒ 31).
Zoom in (JPEG) Zoom out (JPEG)	Enlarge or shrink the still picture (⇒ 31).

## ■ Using the Control Panel

Using the Control Panel, you can operate search backward, search forward, stop, etc. with the TV remote control.

Select “Control Panel” and press [OK] in step 2 (⇒ above).

The Control Panel is displayed (⇒ right).

- When playing a title or DVD-Video, etc.
  - [▲]: Pause, [▼]: Stop, [◀]: Search backward, [▶]: Search forward, [OK]: Play, [EXIT]: Exit the Control Panel.
- While playing still pictures
  - [▼]: Stop, [◀]: View previous picture, [▶]: View next picture, [EXIT]: Exit the Control Panel.

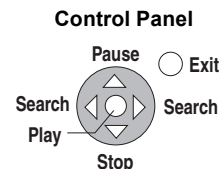

<sup>\*1</sup> This function is available with the TV that supports “HDAVI Control 2” or later.

<sup>\*2</sup> This function is available with the TV that supports “HDAVI Control 3” or later.

## ■ When you want to leave the TV on and set only this unit to standby mode

Press [⏻] on this unit’s remote control and set to standby mode.

## ■ When not using “HDAVI Control”

Set “VIERA Link” in the Setup menu to “Off” (⇒ 63).

**HDD RAM**  
**-R -R DL -RW(V) +R +R DL** (You cannot edit finalised discs.)  
**+RW -RW(VR)**

**Chapter**  
 Each section between the division points becomes a chapter.

**HDD RAM** You can change the order of chapters and create a Playlist (Video) (⇒ 38).

**“Chapter Creation” in the Setup menu (⇒ 61)**  
**“Automatic”:**  
 Detects changes (special mute points like the start and the end of the programme) in the scene during recording and sets chapter start points on them automatically.  
 • Depending on the programme to be recorded or the Recording Mode, the chapter start points may not be created correctly.

**“5 minutes”:**  
 Sets chapter start points automatically during recording at approximately 5-minute interval.

- The maximum number of items on a disc:  
**HDD**  
 – Titles: 499  
 – Chapters: Approx. 1000 per title (Depends on the state of recording.)  
**RAM -R -R DL -RW(V) +R +R DL +RW**  
 – Titles: 99 (**+R +R DL +RW** 49 titles)  
 – Chapters: Approx. 1000 (**+R +R DL +RW** Approx. 254) (Depends on the state of recording.)

**Note**

- Once deleted, divided or partially deleted, recorded content cannot be restored to its original state. Make certain before proceeding.
- You cannot edit during recording or copying, etc.
- Restricted recording information remains even after editing (e.g. dividing a title etc).
- **+R +R DL** Each time you edit a title the information is saved to the free space on the disc. If you do this numerous times, the amount of free space decreases.  
 We recommend that you edit on the HDD and then copy to disc.

## Editing titles/chapters and playing chapters

You can modify (remove unnecessary parts, divide, etc.) recorded programmes.

- Preparation**
- Turn on the television and select the appropriate AV input to suit the connection to this unit.
  - Turn the unit on.
  - Press [DRIVE SELECT] to select the drive containing the recorded title to be edited.
  - **RAM** Release protection (⇒ 56, Setting the protection).

**1** During play or while stopped  
 Press [DIRECT NAVIGATOR].

**HDD RAM** When “VIDEO” is not selected, press the “Red” button to select “VIDEO”.

**2** Press [▲, ▼, ◀, ▶] to select the title.

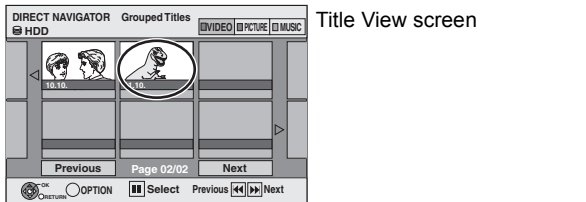

**To show other pages**  
 Press [▲, ▼, ◀, ▶] to select “Previous” or “Next” and press [OK].  
 • You can also press [◀◀, ▶▶] to show other pages.

**Multiple editing**  
 Select with [▲, ▼, ◀, ▶] and press [■]. (Repeat.)  
 A check mark appears. Press [■] again to cancel.

- 3** Press [OPTION].  
**4** Press [▲, ▼] to select the operation and press [OK].  
 • If you select “Edit”, press [▲, ▼] to select the operation and press [OK].

Enter Title Name  
 Set up Protection  
 Cancel Protection  
 Partial Delete  
 Change Thumbnail  
 Divide Title

Delete  
 Properties  
 Edit

Create Group  
 Release Grouping  
 Chapter View  
 Table Display  
 All Titles  
 PICTURE/MUSIC

Refer to “Title operations” (⇒ 37).

To edit the group of titles **HDD** (⇒ 27)  
 ⇒ below  
 Switching the DIRECT NAVIGATOR appearance (⇒ 27)  
 • Playing still pictures (⇒ 30)  
 • To play music recorded on HDD (⇒ 32)

- If you select “Chapter View”
- 5** Press [▲, ▼, ◀, ▶] to select the chapter.  
 To start play ⇒ Press [OK].  
 To edit ⇒ Step 6.

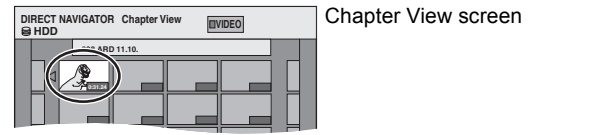

- To show other pages/Multiple editing (⇒ left)
- 6** Press [OPTION], then [▲, ▼] to select the operation and press [OK].

Delete Chapter  
 Create Chapter  
 Combine Chapters  
 Title View

Refer to “Chapter operations” (⇒ 37).

• You can go back to Title View.

**To return to the previous screen**  
 Press [RETURN ↵].

**To exit the screen**  
 Press [DIRECT NAVIGATOR].

## Title operations

After performing steps 1–4 (⇒ 36)

### Delete\*

HDD RAM -R -R DL -RW(V)  
+R +R DL +RW

Press [◀, ▶] to select “Delete” and press [OK].

- Once deleted, the recorded contents are lost and cannot be restored. Make certain before proceeding.
- The available recording space on DVD-R, DVD-R DL, +R or +R DL does not increase when you delete titles.
- Available recording space on DVD-RW (DVD-Video format) and +RW increases only when the last recorded title is deleted. It does not increase if other titles are deleted (⇒ 19).

### Properties

HDD RAM -R -R DL -RW(V)  
+R +R DL +RW -RW(VR)

Information (e.g., time and date) is shown.

- Press [OK] to exit the screen.



### Enter Title Name

HDD RAM -R -R DL -RW(V)  
+R +R DL +RW

You can give names to recorded titles.

(⇒ 44, Entering text)

- **HDD** Even if the group name is changed, the title names in the group will not be changed.

### Set up Protection\*

HDD RAM +R +R DL +RW

If set, this will protect the title from accidental deletion.

Press [◀, ▶] to select “Yes” and press [OK].

The lock symbol appears when the title is protected.

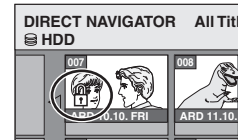

### Partial Delete

HDD RAM

(⇒ below, For your reference)

You can remove unnecessary part of the recording.

- 1 Press [OK] at the start point and end point of the section you want to delete.
- 2 Press [▲, ▼] to select “Finish” and press [OK].
  - Select “Next” and press [OK] to delete other sections.
- 3 Press [◀, ▶] to select “Delete” and press [OK].



### Change Thumbnail

HDD RAM -R -R DL -RW(V)  
+R +R DL +RW

(⇒ below, For your reference)

You can change an image to be shown as the thumbnail picture in the Title View.

- 1 Press [▶] (PLAY) to start play.
- 2 Press [OK] when the image you want to use as a thumbnail is shown.
  - To change the thumbnail
  - Restart play and press [▲, ▼] to select “Change”, then press [OK] at the point you want to change.
- 3 Press [▲, ▼] to select “Finish” and press [OK].

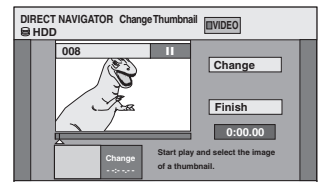

### Divide Title

HDD RAM

(⇒ below, For your reference)

You can divide a title into two.

- 1 Press [OK] at the point you want to divide the title.
- 2 Press [▲, ▼] to select “Finish” and press [OK].
- 3 Press [◀, ▶] to select “Divide” and press [OK].

To confirm the division point

Press [▲, ▼] to select “Preview” and press [OK]. (The unit plays 10 seconds before and after the division point.)

To change the division point

Restart play and press [▲, ▼] to select “Divide”, then press [OK] at the point where you want to divide the title.

#### Note

- The divided titles retain the title name and CPRM property (⇒ 78) of the original title.
- Video and audio just before and after the dividing point may momentarily cut out.
- **HDD** Divided titles form a group of titles.

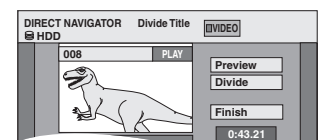

\* Multiple editing is possible.

## Chapter operations

After performing steps 1–6 (⇒ 36)

### Delete Chapter\*

HDD RAM

Press [◀, ▶] to select “Delete” and press [OK].

- Once deleted, the recorded contents are lost and cannot be restored. Make certain before proceeding.
- Select “Combine Chapters” (⇒ below) when you only want to delete the division point between chapters. (The recorded contents will not be deleted.)

### Create Chapter

HDD RAM

(⇒ below, For your reference)

Select the point where you want to start a new chapter while viewing the title.

- 1 Press [OK] at the point you want to divide.
  - Repeat this step to divide at other points.
- 2 Press [▲, ▼] to select “Finish” and press [OK].

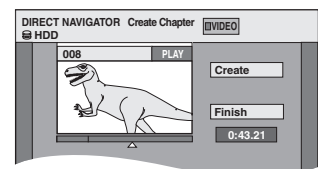

### Combine Chapters

HDD RAM

Press [◀, ▶] to select “Combine” and press [OK].

- The selected chapter and following chapter are combined.

\* Multiple editing is possible.

#### For your reference

- Use Search (⇒ 26), Time Slip (⇒ 26) to find the desired point.
- To find the desired point correctly, use Slow-motion (⇒ 26) and Frame-by-frame (⇒ 26).
- To skip to the start or end of a title/chapter, press [◀◀] (start) or [▶▶] (end).

You can arrange the chapters (⇒ 36) to create a Playlist (Video).

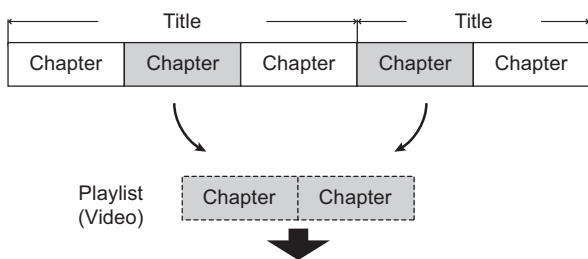

Copying (⇒ 45) a Playlist (Video) will create a title.

- Playlists (Video) are not recorded separately so this doesn't use much capacity.
- Editing chapters in a Playlist (Video) does not modify the source titles and source chapters.
- You cannot create or edit Playlists (Video) while recording or copying.

## HDD RAM

- The maximum number of items on a disc:
  - Playlists (Video): 99
  - Chapters in Playlists (Video): Approx. 1000 (Depends on the state of recording.)
- If you exceed the maximum numbers of items for a disc, all the items entered will not be recorded.

## Creating Playlists (Video)

### HDD RAM

#### Preparation

- Turn on the television and select the appropriate AV input to suit the connection to this unit.
- Turn the unit on.
- Press [DRIVE SELECT] to select the drive containing the recorded title to be edited.
- **RAM** Release protection (⇒ 56, Setting the protection).
- Playlists (Video) must be made in accordance with the encoding system currently selected in "TV System" (⇒ 63).

- 1 While stopped  
Press [FUNCTION MENU].
- 2 Press [▲, ▼] to select "Others" and press [OK].
- 3 Press [▲, ▼] to select "Playlists" and press [OK].

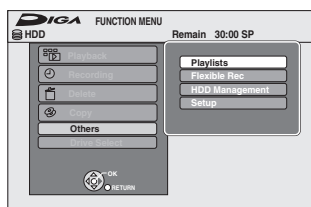

### HDD

When "VIDEO" is not selected, press the "Red" button to select "VIDEO".



- 4 Press [▲, ▼, ◀, ▶] to select "Create" and press [OK].



- 5 Press [◀, ▶] to select the source title and press [▼].

- Press [OK] to select all the chapters in the title, then skip to step 7.

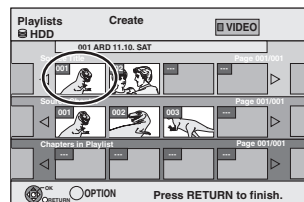

- 6 Press [◀, ▶] to select the chapter you want to add to a Playlist (Video) and press [OK].

Press [▲] to cancel.

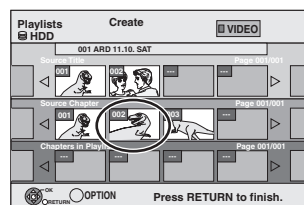

- You can also create a new chapter from the source title. Press [OPTION] to select "Create Chapter" and press [OK] (⇒ 37, Create Chapter).

- 7 Press [◀, ▶] to select the position to insert the chapter and press [OK].

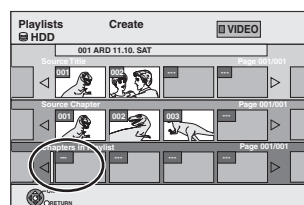

- Press [▲] to select other source titles.
- Repeat steps 6–7 to add other chapters.

- 8 Press [RETURN ↵].

All the selected scenes become the Playlist (Video).

**To return to the previous screen**

Press [RETURN ↵].

**To exit the screen**

Press [EXIT].

## Editing and playing Playlists (Video)/ chapters

**HDD RAM**  
-RW(VR) (Play only)

- 1 While stopped  
Press [FUNCTION MENU].
- 2 Press [▲, ▼] to select “Others” and press [OK].
- 3 Press [▲, ▼] to select “Playlists” and press [OK].

**HDD**

When “VIDEO” is not selected, press the “Red” button to select “VIDEO”.

- 4 Press [▲, ▼, ◀, ▶] to select the Playlist (Video).

To start play ⇒ Press [OK].  
To edit ⇒ Step 5.



• To show other pages/Multiple editing (⇒ 36)

- 5 Press [OPTION], then [▲, ▼] to select the operation and press [OK].

• If you select “Edit”, press [▲, ▼] to select the operation and press [OK].

e.g. **HDD**

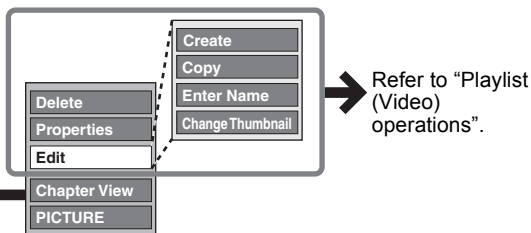

■ If you select “Chapter View”

- 6 Press [▲, ▼, ◀, ▶] to select the chapter.

To start play ⇒ Press [OK].  
To edit ⇒ Step 7.

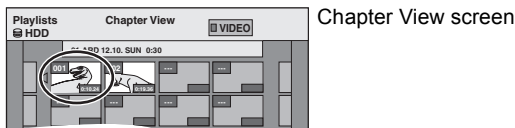

• To show other pages/Multiple editing (⇒ 36)

- 7 Press [OPTION], then [▲, ▼] to select the operation and press [OK].

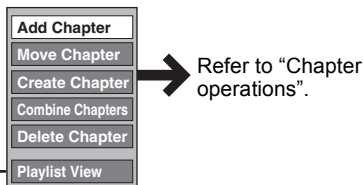

• You can go back to Playlist View ( Video ).

To return to the previous screen

Press [RETURN ↵].

To exit the screen

Press [EXIT].

## Playlist (Video) operations

After performing steps 1–5 (⇒ left)

<b>Delete</b> * <b>HDD RAM</b>	Press [◀, ▶] to select “Delete” and press [OK]. Once deleted, the Playlists (Video) are lost and cannot be restored. Make certain before proceeding.
<b>Properties</b> <b>HDD RAM</b> -RW(VR)	Playlist (Video) information (e.g., total time and date) is shown. • Press [OK] to exit the screen.
<b>Create</b> <b>HDD RAM</b>	(⇒ 38, Creating Playlists (Video), Step 5–8)
<b>Copy</b> * <b>HDD RAM</b>	Press [◀, ▶] to select “Copy” and press [OK]. • The copied Playlist (Video) becomes the newest one in “Playlist View ( Video )” screen.
<b>Enter Name</b> <b>HDD RAM</b>	You can give names to Playlists (Video). (⇒ 44, Entering text)
<b>Change Thumbnail</b> <b>HDD RAM</b>	(⇒ 37, Change Thumbnail)

\* Multiple editing is possible.

## Chapter operations

**HDD RAM**

After performing steps 1–7 (⇒ left)

• Editing chapters in a Playlist (Video) does not modify the source titles and source chapters.

<b>Add Chapter</b>	(⇒ 38, Creating Playlists (Video), Step 5–7)
<b>Move Chapter</b>	Press [▲, ▼, ◀, ▶] to select the position to insert the chapter and press [OK].
<b>Create Chapter</b>	(⇒ 37, Create Chapter)
<b>Combine Chapters</b>	(⇒ 37, Combine Chapters)
<b>Delete Chapter</b> *	(⇒ 37, Delete Chapter) The Playlist (Video) itself is deleted if you delete all the chapters in it.

\* Multiple editing is possible.

## Editing still pictures (JPEG)

**HDD** **-R** (JPEG) **RAM**

- You can edit pictures and albums.
- You cannot edit still pictures recorded on DVD-R DL, CD-R/CD-RW and USB memory.
- You cannot edit still pictures recorded on finalised DVD-R.

### Preparation

- Press [DRIVE SELECT] to select the HDD or DVD drive.
- **RAM** Release protection (⇒ 56, Setting the protection).

## 1 Press [DIRECT NAVIGATOR].

**HDD** **RAM** When "PICTURE" is not selected, press the "Green" button to select "PICTURE".

## 2 Editing an album:

### Select the album to be edited and press [OPTION].

- When you want to create an album using "Create Album", press [OPTION] without selecting album.

#### Editing a still picture:

- ① Select the album which contains the still picture to edit and press [OK].
- ② Select the still pictures to edit and press [OPTION].

#### To show other pages

Press [▲, ▼, ◀, ▶] to select "Previous" or "Next" and press [OK].

- You can also press [◀◀, ▶▶] to show other pages.

#### Multiple editing

Select with [▲, ▼, ◀, ▶] and press [■]. (Repeat.)

A check mark appears. Press [■] again to cancel.

#### To select all albums

Press [■]. After confirmation message appears, press [◀, ▶] to select "Yes".

## 3 Press [▲, ▼] to select the operation and press [OK].

### ■ To edit the album

(e.g., **HDD**)

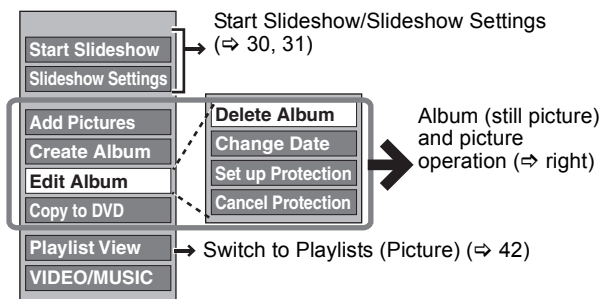

### ■ To edit still picture

(e.g., **HDD**)

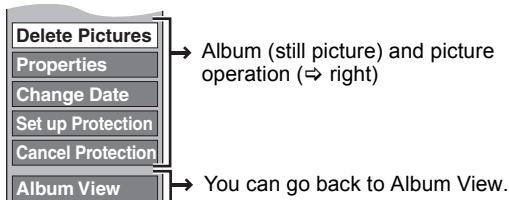

### To return to the previous screen

Press [RETURN ↵].

### To exit the screen

Press [DIRECT NAVIGATOR].

## Album (still picture) and picture operation

After performing steps 1–3 (⇒ left)

### Delete Pictures\*

### Delete Album\*

**HDD**  
**-R** (JPEG)  
**RAM**

Press [◀, ▶] to select "Delete" and press [OK].

- Once deleted, the recorded contents are lost and cannot be restored. Make certain before proceeding.

- When deleting an album, files other than the still picture files inside the album will also be deleted. (This does not apply to folders under the album concerned.)

- **-R** Available space does not increase even after pictures are deleted.

### Change Date\*

**HDD** **RAM**

You can change the date of the picture.

- ① Press [◀, ▶] to select the item and press [▲, ▼] to change.
- ② Press [OK].

### Enter Album Name

**HDD** **RAM**

You can give names to albums. (⇒ 44, Entering text)

- Album names input using this unit may not be displayed on other equipment.

### Set up Protection\*

### Cancel Protection\*

**HDD** **RAM**

If set, this will protect the still picture or album from accidental deletion.

Press [◀, ▶] to select "Yes" and press [OK].

The lock symbol appears when the still picture or album is protected.

- Even if the protection setting is used by this unit to protect an album, the album may be deleted by another unit.

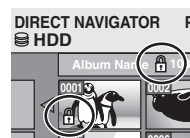

### Properties

**HDD** **RAM** **-R**  
**-R** DL **CD**  
**USB**

Information (e.g., image size and file size) is shown.

- To exit the Properties screen, press [OK].

### Add Pictures

### Create Album

**HDD** **RAM**

- ① Press [◀, ▶] to select "Start" or "Yes" and press [OK].

- ② Press [▲, ▼, ◀, ▶] to select the album that contains the still picture you want to add and press [OK].

- ③ Press [▲, ▼] to select the item and press [OK].

- If "Select pictures to copy" is selected: Select the still picture you want to add and press [OK].

- If "Copy all pictures" is selected: All the still pictures in the album will be copied.

- ④ Press [◀, ▶] to select "Yes" or "No" and press [OK].

- If you want to continue copying, select "Yes" and go to step ②.

#### Only for "Create Album"

- ⑤ Press [◀, ▶] to select "Yes" or "No" and press [OK].

- If "Yes" is selected:

You can give names to albums. (⇒ 44, Entering text)

- If "No" is selected:

The album name is automatically given.

### Copy to DVD\*

**HDD**

For copy to DVD-RAM or HDD  
Press [◀, ▶] to select "Start" and press [OK].

### Copy to HDD\*

**RAM**

For copy to DVD-R

Press [◀, ▶] to select "Copy & Finalise" or "Copy Only" and press [OK].

- **-R** Use blank discs or unfinalised discs on which JPEG images are recorded with this unit.

\* Multiple editing is possible.

[Change Date : Only when the "Picture (JPEG) View" screen is displayed]



**Note**

- Timer recordings do not start when performing “Change Date”, “Copy to DVD”, “Copy to HDD”, “Add Pictures” or “Create Album”.
- **RAM** “Add Pictures” is available only for the folders conforming to DCF.
- If you want to delete sample pictures, perform “Cancel Protection” and then delete them. (⇒ 40)
- “Sample Music” is not displayed on the MUSIC screen.

## Editing music

**HDD****Preparation**

Press [DRIVE SELECT] to select the HDD drive.

**1 Press [DIRECT NAVIGATOR].**

When “MUSIC” is not selected, press the “Yellow” button to select “MUSIC”.

**2 Editing an album:**

**Press [▲, ▼] to select the album and press [OPTION].**

Editing a track:

- 1 Press [▲, ▼] to select the album and press [OK].
- 2 Press [▲, ▼] to select the track and press [OPTION].

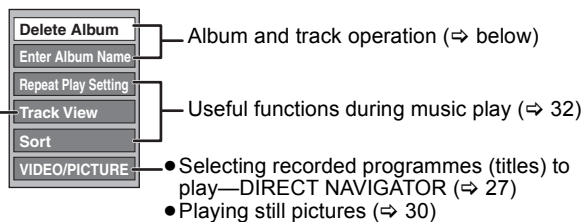
**3 Press [▲, ▼] to select the operation and press [OK].****■ To edit the album (Music)**

⇒ below

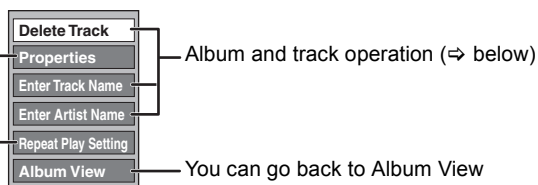
**■ To edit the track (Music)**

Useful functions during music play (⇒ 32)

**To return to the previous screen**

Press [RETURN ↵].

**To exit the screen**

Press [DIRECT NAVIGATOR].

## Album and track operation

After performing steps 1-3 (⇒ above)

<b>Delete Album</b> <b>Delete Track</b>	Press [◀, ▶] to select “Delete” and press [OK]. • Once deleted, the recorded contents are lost and cannot be restored. Make certain before proceeding.
<b>Enter Album Name</b> <b>Enter Track Name</b>	You can give names to albums and tracks. (⇒ 44, Entering text)
<b>Enter Artist Name</b>	You can edit the artist name of the track. (⇒ 44, Entering text)

**Note**

- When the timer recording starts, editing music stops on the way.

## Deleting still pictures and music using DELETE Navigator

**HDD -R (JPEG) RAM**

- 1 While stopped  
Press [FUNCTION MENU].
- 2 Press [▲, ▼] to select “Delete” and press [OK].
- 3 Press [▲, ▼] to select “Picture” or “Music”.
- 4 Press [OK].
- 5 Deleting an album  
Press [▲, ▼, ◀, ▶] to select the item and press [DELETE \*].

Deleting a still picture or track

- 1 Press [▲, ▼, ◀, ▶] to select the album which contains the still picture or track to delete and press [OK].
- 2 Press [▲, ▼, ◀, ▶] to select the still picture or track and press [OK].

You can confirm the item that you have selected using the option menu.

- Refer to option menu operations
  - for Still pictures ⇒ 40, step 3
  - for Music ⇒ left, step 3

**To show other pages [Album (still picture) and still picture only]**

Press [◀◀, ▶▶] to show other pages.

**Multiple deleting [Album (still picture) and still picture only]**

Select with [▲, ▼, ◀, ▶] and press [■]. (Repeat.) A check mark appears. Press [■] again to cancel.

**6 Press [◀, ▶] to select “Delete” and press [OK].**

The item is deleted.

**To return to the previous screen**

Press [RETURN ↵].

**To exit the screen**

Press [EXIT].

You can arrange favourite still pictures in albums stored on HDD to create a Playlist (Picture).

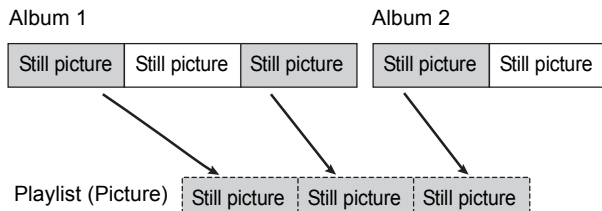

Copying (⇒ 50) a Playlist (Picture) will create an album. (Background Music cannot be copied.)

- Playlists (Picture) are not recorded separately so this doesn't use much capacity.
- Editing still pictures in a Playlist (Picture) does not modify the source albums or source still pictures.
- You cannot create or edit Playlists (Picture) while recording or copying.

- The maximum number of Playlists (Picture):
  - Playlists: 99
  - Pictures in a Playlist (Picture): Approx. 3000

## Creating Playlists (Picture)

### HDD

You can create Playlists (Picture) with Background Music.

#### Preparation

Press [DRIVE SELECT] to select the HDD drive.

- 1 While stopped  
Press [FUNCTION MENU].
- 2 Press [▲, ▼] to select “Others” and press [OK].
- 3 Press [▲, ▼] to select “Playlists” and press [OK].

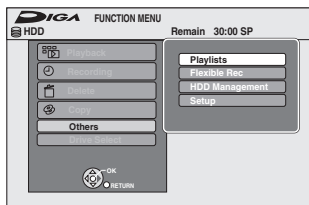

When “PICTURE” is not selected, press the “Green” button to select “PICTURE”.

- 4 Press [▲, ▼, ◀, ▶] to select “Create” and press [OK].

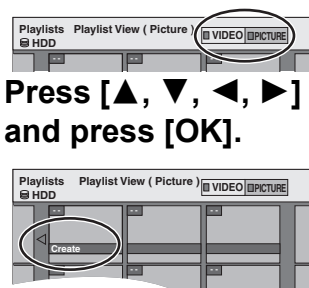

- 5 Press [◀, ▶] to select an album (a folder) in “Source Albums” and press [▼].

- Press [OK] to select all still pictures in the album, then skip to step 8.
- Press [▲] to cancel.

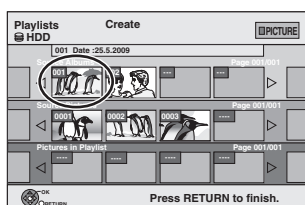

- 6 Press [◀, ▶] to select the still picture you want to add to a Playlist (Picture) and press [■].

A check mark is displayed. Repeat this step until you select all necessary items.

- Press [■] again to cancel.

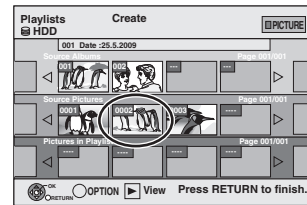

- 7 Press [OK].

- 8 Press [◀, ▶] to select the position to insert the still picture and press [OK].

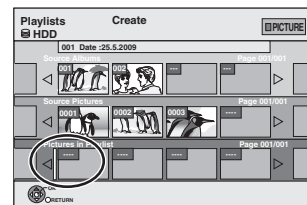

- Press [▲] to select other “Source Albums” and repeat steps 5–8 to add pictures in other albums.

- 9 Press [RETURN ↵].

- 10 Press [◀, ▶] to select “Yes” if you want to name the Playlist (Picture).



(⇒ 44, Entering text)

- 11 Select the Background Music if you want to change Background Music.

- If “No” is selected, Sample Music is set for Background Music.

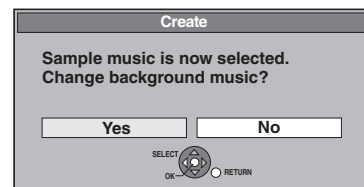

- ① Press [◀, ▶] to select “Yes” and press [OK].
- ② Press [▲, ▼] to select the storage location of Background Music and press [OK].
  - “Sample Music” is Background Music pre-installed on HDD.
- ③ Press [▲, ▼] to select an album for Background Music and press [OK] when selecting other than “Sample Music”.
  - Background Music on Playlists (Picture) is specified for each Playlist (Picture). (⇒ 43)

All the selected pictures become a Playlist (Picture).

#### To return to the previous screen

Press [RETURN ↵].

#### To exit the screen

Press [EXIT].

## Editing Playlists (Picture)/still pictures

HDD

- 1 While stopped  
Press [FUNCTION MENU].
- 2 Press [▲, ▼] to select “Others” and press [OK].
- 3 Press [▲, ▼] to select “Playlists” and press [OK].  
• When “PICTURE” is not selected, press the “Green” button to select “PICTURE”.
- 4 Editing a Playlist (Picture):  
Select the Playlist (Picture) to be edited and press [OPTION].

Editing a still picture:

- ① Select the Playlist (Picture) which contains still pictures to edit and press [OK].
- ② Select the still pictures to edit and press [OPTION].

To show other pages

Press [▲, ▼, ◀, ▶] to select “Previous” or “Next” and press [OK].

• You can also press [◀◀, ▶▶] to show other pages.

Multiple editing

Select with [▲, ▼, ◀, ▶] and press [■]. (Repeat.)

A check mark appears. Press [■] again to cancel.

- 5 Press [▲, ▼] to select the operation and press [OK].

### ■ To edit the Playlist (Picture)

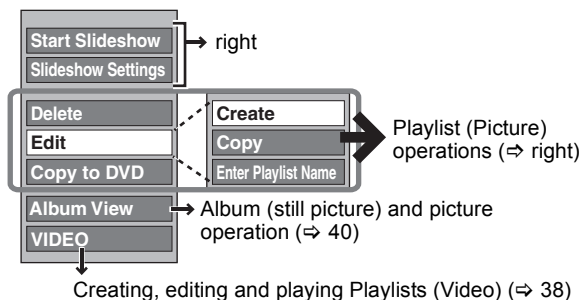

### ■ To edit still picture

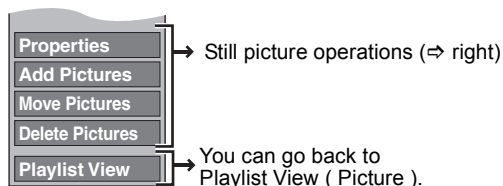

To return to the previous screen

Press [RETURN ↵].

To exit the screen

Press [EXIT].

## Playlist (Picture) operations

HDD

- After performing steps 1–5 (⇒ left)

Start Slideshow	(⇒ 30, Start Slideshow, Steps 1-2) • You cannot select multiple Playlists (Picture) or all Playlists (Picture).
Slideshow Settings	(⇒ 31, Slideshow Settings) • Slideshow Settings are retained only for the specified Playlist (Picture). • Music CD (CD-DA) is used for Background Music when inserting Music CD.
Delete*	Press [◀, ▶] to select “Delete” and press [OK]. Once deleted, the Playlists (Picture) are lost and cannot be restored. Make certain before proceeding.
Copy to DVD*	For copy to DVD-RAM Press [◀, ▶] to select “Start” and press [OK]. For copy to DVD-R Press [◀, ▶] to select “Copy & Finalise” or “Copy Only” and press [OK]. • [R] Use blank discs or unfinalized discs on which JPEG images are recorded with this unit.
Create	(⇒ 42, Creating Playlists (Picture), Step 5–11)
Copy*	Press [◀, ▶] to select “Copy” and press [OK]. • The copied Playlist (Picture) becomes the newest one in “Playlist View (Picture)” screen.
Enter Playlist Name	You can give names to Playlists (Picture). (⇒ 44, Entering text)

\* Multiple editing is possible.

## Still picture operations

HDD

- After performing steps 1–5 (⇒ left)

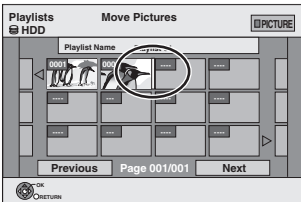
Properties	(⇒ 40, Album (still picture) and picture operation)
Add Pictures	(⇒ 42, Creating Playlists (Picture), Step 5–9)
Move Pictures	Press [▲, ▼, ◀, ▶] to select the position to insert the picture and press [OK]. 
Delete Pictures*	Press [◀, ▶] to select “Delete” and press [OK].

\* Multiple editing is possible.

**HDD RAM -R -R DL -RW(V) +R +R DL +RW**

You can give names to recorded titles, etc.

## 1 Show Enter Title Name screen etc.

### Title (timer recording)

Select "Programme Name". (⇒ 24, Manually programming timer recordings, step 3)

### Title

Select "Enter Title Name". (⇒ 36, step 4)

### Playlist (Video)

Select "Enter Name". (⇒ 39, step 5)

### Playlist (Picture)

Select "Enter Playlist Name". (⇒ 43, step 5)

### Album of still pictures

Select "Enter Album Name". (⇒ 40, Editing still pictures (JPEG), step 3)

### Album (CD/MP3) (HDD)

Select "Enter Album Name". (⇒ 41, Editing music, step 3)

### Track (CD/MP3) (HDD)

Select "Enter Track Name". (⇒ 41, Editing music, step 3)

### Artist (CD/MP3) (HDD)

Select "Enter Artist Name". (⇒ 41, Editing music, step 3)

### Disc

Select "Disc Name". (⇒ 57, Providing a name for a disc, step 1)

### Favourite 1-4

Press the "Red" button. (⇒ 59, To change the name of a Favourite in the "Favourite" column, step ②)

**Name field:** shows the text you have entered

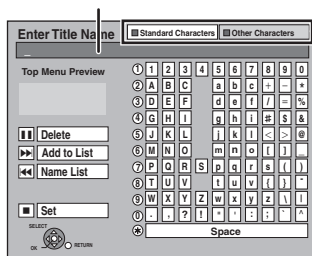

Press the "Red" button or "Green" button to select character type and press [OK].

"Standard Characters":  
(⇒ left, Alphabet characters, etc.)

"Other Characters":  
(⇒ below, Umlaut characters, accented characters, etc.)

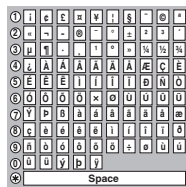

## 2 Press [▲, ▼, ◀, ▶] to select a character and press [OK].

Repeat this step to enter other characters.

### •To delete a character

Press [▲, ▼, ◀, ▶] to select the character in the name field and press [II]. (The selected characters are deleted.)

### •Using the numbered buttons to enter characters

e.g., entering the letter "R"

① Press [7] to move to the 7th row.

② Press [7] twice to highlight "R".

③ Press [OK].

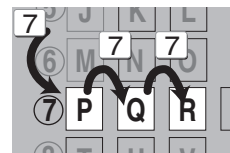

### •To enter a space

Press [DELETE \*] and press [OK].

## 3 Press [■] (Set).

### To end partway

Press [RETURN ↵].

Text is not added.

### ■ To add a name to the list

You can add frequently used names and recall them later.

Maximum number of added names: 20

Maximum number of characters per name: 44

After entering the name (steps 1-2).

1 Press [▲, ▼, ◀, ▶] to select "Add to List" and press [OK].

• You can also press [▶▶] to select "Add to List".

2 Press [◀, ▶] to select "Add" and press [OK].

• Press [RETURN ↵] to cancel.

### ■ To recall an added name

1 Press [▲, ▼, ◀, ▶] to select "Name List" and press [OK].

• You can also press [◀◀] to select "Name List".

2 Press [▲, ▼, ◀, ▶] to select the name to be recalled and press [OK].

### ■ To delete an added name

1 Press [▲, ▼, ◀, ▶] to select "Name List" and press [OK].

• You can also press [◀◀] to select "Name List".

2 Press [▲, ▼, ◀, ▶] to select the name to be deleted.

3 Press [OPTION] to show "Delete Name" and press [OK].

4 Press [◀, ▶] to select "Delete" and press [OK].

5 Press [RETURN ↵].

### For your reference

If you enter a long name, only part of it is shown in the Top Menu after finalisation (⇒ 58). When entering a title name, the name that will appear in the Top Menu can be previewed in "Top Menu Preview" window.

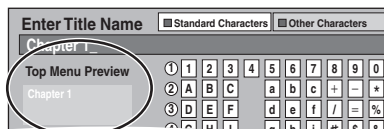

### Note

- If a name is long, parts of it may not be shown in some screens.
- The number of characters that can be entered depends on what kind of things you name.

# Copying titles or Playlists (Video)

		Copy [Video (HDD to DVD)]		Advanced Copy	
<b>Features</b>		Easy copying from HDD to DVD with no difficult settings.		Make a copy list and then copy. You can set the unit to copy titles or Playlists (Video) in the way you want.	
<b>Copy direction</b>	HDD → DVD	○		○	
	DVD → HDD	-		○	
<b>High speed mode copy<sup>*1</sup></b>		○		○	
<b>Changing recording mode</b>		-		○ <sup>*2</sup>	
<b>Finalise<sup>*3</sup></b>		-R -R DL -RW(V) +R +R DL Automatically finalised		-R -R DL -RW(V) +R +R DL Can be selected	
		<b>High speed mode</b>	<b>Normal speed mode</b>	<b>High speed mode</b>	<b>Normal speed mode</b>
<b>Copying Playlists (Video)<sup>*4</sup></b>		-	-	○	○
<b>Are chapters maintained?</b>		○	- <sup>*5</sup>	○	- <sup>*5</sup>
<b>Are thumbnails maintained?</b>		○	- <sup>*6</sup>	○ <sup>*7</sup>	- <sup>*6</sup>
<b>Recording or Playing while Copying</b>		-	-	○ <sup>*8</sup>	-

<sup>\*1</sup> To high speed copy titles (or Playlists (Video) created from those titles), set "Rec for High Speed Copy" to "On" before recording to the HDD (The default setting is "On". ⇒ 61).

However in the following cases, copying to DVD-R, DVD-R DL, DVD-RW (DVD-Video format), +R, +R DL and +RW using the high speed mode does not work.

- When arranging multiple titles for copying, if any titles are recorded with "Rec for High Speed Copy" to "Off", then you cannot perform with high-speed copy.
- Playlists (Video) created from titles using a variety of recording modes or multiple titles using FR recording mode.
- Playlists (Video) mixed with a variety of audio types (Dolby Digital and LPCM, etc.).
- Titles that contain many deleted segments.
- Titles that have been copied to the HDD from a Panasonic digital video camera with HDD (SD Video).

- +R +R DL +RW Titles recorded in "EP" mode and "FR (recordings 5 hours or longer)" mode. (Displayed ►►!)

- +R +R DL +RW Titles recorded in 16:9 aspect

- -R -R DL -RW(V) Titles recorded in 16:9 aspect using "EP" mode or "FR" (recordings 5 hours or longer) mode

<sup>\*2</sup> If you select a recording mode with better picture quality than the original, the picture quality does not improve. (However it does prevent against degradation of picture quality.)

+R DL You cannot copy in "EP" or "FR (recordings 5 hours or longer)" mode.

<sup>\*3</sup> You cannot select "Top Menu" or "Auto-Play Select".

If you want to set auto-play select or the background colour, select "Top Menu" or "Auto-Play Select" in "DVD Management" before copying (⇒ 58).

<sup>\*4</sup> You cannot copy Playlists (Video) with a play time more than 8 hours.

When you copy a Playlist (Video), it will become a title in the destination drive.

<sup>\*5</sup> RAM -R DL +R DL +RW : One title becomes one chapter.

-R -RW(V) +R : Chapters are created automatically (-R -RW(V) about 5 minutes +R about 8 minutes) when finalising after copying the disc.

<sup>\*6</sup> Thumbnails return to the default position.

<sup>\*7</sup> When copying Playlists (Video), the thumbnails may not reflect changes made to them.

<sup>\*8</sup> Possible only with titles on the HDD

(However it is not possible when copying with automatic finalisation.)

- You cannot perform chasing play or edit, etc. while copying.

- You cannot play a Playlist (Video) while copying titles with "One time only recording" restriction (⇒ 20).

- Still pictures or music cannot be played.

## ■ Approximate copying times (Max. speed)

(excludes time required to write data management information)

HDD		5X Speed DVD-RAM		12X Speed DVD-R <sup>*1</sup>		4X Speed DVD-R DL <sup>*2</sup>		4X Speed DVD-RW <sup>*3</sup>		8X Speed +R <sup>*4</sup>		4X Speed +R DL <sup>*2</sup>		4X Speed +RW	
Recording Mode	Recorded	Required time	Speed	Required time	Speed	Required time	Speed	Required time	Speed	Required time	Speed	Required time	Speed	Required time	Speed
XP	1 hour	12 min.	5x	5 min. 46 s.	10x	15 min.	4x	15 min.	4x	8 min. 20 s.	7x	15 min.	4x	15 min.	4x
SP		6 min.	10x	2 min. 30 s.	24x	7 min. 30 s.	8x	7 min. 30 s.	8x	3 min. 45 s.	16x	7 min. 30 s.	8x	7 min. 30 s.	8x
LP		3 min.	20x	1 min. 21 s.	44x	3 min. 45 s.	16x	3 min. 45 s.	16x	1 min. 53 s.	32x	3 min. 45 s.	16x	3 min. 45 s.	16x
EP(6 hours)		2 min.	30x	58 s.	62x	2 min. 30 s.	24x	2 min. 30 s.	24x						
EP(8 hours)		1 min. 30 s.	40x	48 s.	75x	1 min. 53 s.	32x	1 min. 57 s.	31x						

• The above rated value indicates the fastest time and speed required for copying 1 hour title from HDD to each disc in the above list supporting High-Speed copying. The amount of time and speed may vary depending on the conditions such as the area on where information is written or unique feature on the disc.

<sup>\*1</sup> In this unit, copying with a 16X Speed DVD-R disc will be performed at the same speed as with a 12X Speed DVD-R disc.

<sup>\*2</sup> In this unit, copying with 8X Speed discs, DVD-R DL and +R DL, will be performed at the same speed as with 4X Speed discs, DVD-R DL and +R DL.

<sup>\*3</sup> In this unit, copying with a 6X Speed DVD-RW disc will be performed at the same speed as with a 4X Speed DVD-RW disc.

<sup>\*4</sup> In this unit, copying with a 16X Speed +R disc will be performed at the same speed as with a 8X Speed +R disc.

### Note

- When recording or playing while copying, the unit may not use the maximum recording speed.

- Depending on the condition of the disc, the unit may not copy using the maximum speed.

### Regarding copying to DVD-R DL (single-sided, Dual Layer) and +R DL (single-sided, Double Layer)

When not copying in high speed mode, titles are temporarily copied at normal speed to the HDD and then copied at high speed to DVD-R DL and +R DL.

The titles that were temporarily copied to the HDD are then deleted.

You cannot copy to DVD-R DL and +R DL in the following cases.

- When there is not enough free space on the HDD. (When copying to a new blank disc, if you intend to fill a new disc when copying to it, the equivalent of up to 4 hours of free space in SP mode is needed on the HDD.)

- When the number of titles recorded to the HDD and the number of titles to be copied to the DVD-R DL and +R DL is greater than 499 in total.

When playing a title recorded on both layers, video and audio may momentarily cut out when the unit is switching layers. (⇒ 11)

### Regarding copying of the broadcasts that allow "One time only recording"

You can copy a recorded title to a CPRM (⇒ 78) compatible DVD-RAM, however, the title is deleted from the HDD.

- Titles or Playlists (Video) cannot be copied from DVD-RAM to the HDD.

- Titles will not be copied if they are protected (⇒ 37).

- You cannot copy Playlists (Video) created from "One time only recording" titles.

- Titles with recording limitations and Playlists (Video) cannot be registered on the same copying list.

**Before copying**

**Speed and recording mode when copying**

**HDD** ↔ **RAM** : High speed

**HDD** → **-R -R DL -RW(V) +R +R DL +RW** : Refer to the following table.

Rec for High Speed Copy (⇒ 61)	Copy speed
Only titles recorded with "Rec for High Speed Copy" set to "On". *	High speed
Only titles recorded with "Rec for High Speed Copy" set to "Off".	Normal speed
When making a copy of multiple titles that were recorded with "Rec for High Speed Copy" set to "On" and "Off".	

\* In the following cases, even if "Rec for High Speed Copy" is set to "On", copy will perform at normal speed.

- **+R +R DL +RW** When the copying source was recorded in "EP" or "FR (recordings 5 hours or longer)" mode.
- When the copy destination (disc) does not have enough space.
- When the title aspect for the copying source and "Aspect for Recording" (⇒ 61) do not match.
- When the title aspect for the copying source is 16:9:
  - **+R +R DL +RW**
  - **-R -R DL -RW(V)** copying source was recorded in "EP" or "FR (recordings 5 hours or longer)" mode.

**Note**

- Titles and Playlists (Video) recorded using a different encoding system (PAL or NTSC) from the TV system currently selected on the unit cannot be copied.
- **-R** Video cannot be copied to a disc with still pictures (JPEG) already recorded on it.
- **-R** Still images cannot be copied to a DVD-R disc with video already recorded on it.

**Preparation**

- Insert a disc that you can use for copying (⇒ 11, 15).
- Confirm that there is enough remaining disc space.

**Copy [Video (HDD to DVD)]**

DVD-R, DVD-R DL, DVD-RW (DVD-Video format), +R and +R DL are automatically finalised (⇒ 78). After finalising, the discs become play-only and you can also play them on other DVD equipment. However, you can no longer record or edit.

**HDD** → **RAM +R -R DL -RW(V) +R +R DL +RW**

(You cannot copy to finalised discs.)

When copying in normal speed, recording mode will be set to FR. (However, if there is still not enough space after setting to FR mode, copy will not be performed.)

- 1 While stopped**  
Press **[FUNCTION MENU]**.
- 2 Press [▲, ▼] to select "Copy" and press [OK].**
- 3 Press [▲, ▼] to select "Video (HDD to DVD)" and press [OK].**

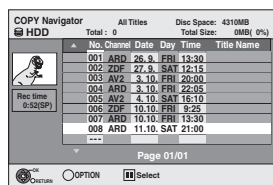

- 4 Press [▲, ▼] to select the title you want to copy and press [II].**

A check mark is displayed. Repeat this step until you select all necessary items.

- Press **[II]** again to cancel.

**To show other pages**

Press **[◀, ▶]** to show other pages.

- 5 Press [OK].**

- 6 After you start copying DVD-R, DVD-R DL, DVD-RW (DVD-Video format), +R and +R DL discs, they become play-only and you can no longer record or edit. Press [◀, ▶] to select "Start" and press [OK].**

Copy starts.

**To return to the previous screen**

Press **[RETURN ↵]**.

**To stop copying (⇒ 47)**

**COPY Navigator/Copying list icons and functions (⇒ 48)**

**To check the properties of a title and sort COPY Navigator**

- 1 Press [▲, ▼] to select the title and press [OPTION].**

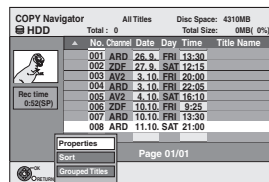

- 2 Press [▲, ▼] to select "Properties" or "Sort" and press [OK].**

**Properties:**

The name, recording date, channel etc. of the selected title are shown.

**Sort (All Titles screen only):**

Press **[▲, ▼] to select the item and press [OK].**

This changes the way that titles are displayed. You can select to display titles by No., channel, recording date, day, recording start time and title name. (You cannot select this item if a title has a check mark.)

If you close the COPY Navigator screen, the display order is cancelled.

**Note**

- When copying titles in high speed mode to high speed recording compatible DVD-RAM 5X, DVD-R 8X, +R 8X or +RW 4X, the sound of the disc rotating becomes louder than normal. If you want copy to perform more quietly, select "Normal ( Silent )" in "DVD Speed for High Speed Copy" in the Setup menu (⇒ 61).
- If you register multiple titles, they are copied in order from the title at the top of the screen and not in the order you registered them. To change the order that titles are copied, create a copying list and then copy the contents of the list (⇒ 47).

## Copying using the copying list- Advanced Copy

HDD → RAM -R -R DL -RW(V) +R +R DL +RW  
RAM -RW(VR) +RW → HDD

You can order titles and Playlists (Video) as desired for copy to disc.

See also “Before copying” (⇒ 46).

- 1 While stopped  
Press [FUNCTION MENU].
- 2 Press [▲, ▼] to select “Copy” and press [OK].
- 3 Press [▲, ▼] to select “Advanced Copy” and press [OK].

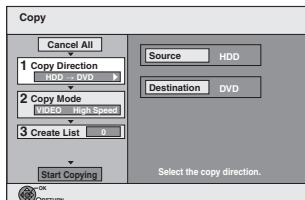

- If you are not going to change the registered list press [▼] several times (⇒ step 7).

### 4 Set the copy direction.

- If you are not going to change the copying direction, press [▼] (⇒ step 5).
- ① Press [▲, ▼] to select “Copy Direction” and press [▶].
- ② Press [▲, ▼] to select “Source” and press [OK].
- ③ Press [▲, ▼] to select the drive and press [OK].  
The same drive as the copy source cannot be selected.
- ④ Press [◀] to confirm.

### 5 Set the recording mode.

- If you are not going to change the recording mode, press [▼] (⇒ step 6).
- ① Press [▲, ▼] to select “Copy Mode” and press [▶].
- ② Press [▲, ▼] to select “Format” and press [OK].
- ③ Press [▲, ▼] to select “VIDEO” and press [OK].
- ④ Press [▲, ▼] to select “Recording Mode” and press [OK].
- ⑤ Press [▲, ▼] to select the mode and press [OK].
- ⑥ Press [◀] to confirm.

### 6 Register titles and Playlists (Video) for copy.

- If you are going to copy a registered list without making any changes to it (⇒ step 7).
- ① Press [▲, ▼] to select “Create List” and press [▶].

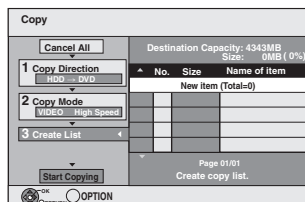

- ② Press [▲, ▼] to select “New item” and press [OK].
- ③ Press the “Red” button to select “VIDEO” or press the “Blue” button to select “Playlists”.

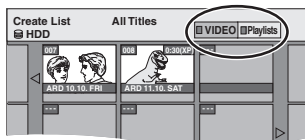

- ④ Press [▲, ▼, ◀, ▶] to select the title or Playlist (Video) and press [■].  
A check mark is displayed. Repeat this step until you select all necessary items.
  - Press [■] again to cancel.
  - The items will be copied in the order of the copying list. If you want to specify the order, repeat selecting one item at a time.
  - When you switch between the “VIDEO” and “Playlists” tab, the check mark is cancelled.
  - When copying to a disc using high speed mode,

-R -R DL -RW(V) : only items indicated with “▶▶▶” or

“▶▶▶” can be registered.

+R +R DL +RW : only items indicated with “▶▶▶” can be registered.

- To show other pages (⇒ below)

⑤ Press [OK].

- To edit the copying list (⇒ 48)

You cannot start copying when the value of the “Size” (⇒ 48) exceeds 100% (“Destination Capacity:” is not sufficient).

⑥ Press [◀] to confirm.

### 7 Press [▲, ▼] to select “Start Copying” and press [OK].

When copying titles in high speed mode to high speed recording compatible DVD-RAM 5X, DVD-R 8X, +R 8X or +RW 4X, the sound of the disc rotating becomes louder than normal.

If you want copy to perform more quietly, select “Normal ( Silent )” in “DVD Speed for High Speed Copy” in the Setup menu (⇒ 61).

### 8 Press [◀, ▶] to select “Yes” and press [OK] to start copying.

HDD → -R -R DL -RW(V) +R +R DL  
Press [◀, ▶] to select “Copy & Finalise” or “Copy Only” and press [OK].

- If “Copy & Finalise” is selected

After finalising, the discs become play-only and you can also play them on other DVD equipment. However, you can no longer record or edit.

#### To show other pages

Press [▲, ▼, ◀, ▶] to select “Previous” or “Next” and press [OK].

- You can also press [◀◀, ▶▶] to show other pages.

#### To stop copying

Press and hold [RETURN ↵] for 3 seconds.  
(You cannot stop while finalising)

#### When High-speed copying

All titles that have completely copied at the point cancelled are copied.

#### When Normal Speed copying

Copies until the point cancelled. However as for titles with “One time only recording” restriction, only titles that have completely copied at the point cancelled are copied to the disc. Titles that are cancelled before the copy is complete are not copied and remain on the HDD.

- -R DL +R DL If copy is cancelled during the step while temporarily copying to the HDD, then nothing will be copied. However, if copy is cancelled during the step while copying to disc from the HDD, then only titles completely copied at the point canceled are copied.

Even if the title was not copied to the DVD-R, DVD-R DL, DVD-RW (DVD-Video format), +R, +R DL or +RW, the amount of remaining writable disc space becomes less.

#### To return to the previous screen

Press [RETURN ↵].

#### Recording and playing while copying

You can record and play using the HDD while high speed copying. (Only when high speed copying without finalising)









- Still pictures and music recorded on the HDD cannot be played. Press [OK] to cancel the screen display.
- To confirm the current progress  
Press [STATUS ⓘ].

#### Note

- Timer recordings executed while copying are recorded to the HDD regardless of the recording drive settings. (Only when high speed copying without finalising)

**COPY Navigator/Copying list icons and functions**

COPY Navigator/Copying list indicators

-  Titles and Playlists (Video) that can be copied in high speed mode to DVD-R, DVD-R DL, DVD-RW (DVD-Video format), +R, +R DL, +RW
-  Titles and Playlists (Video) that can be copied in high speed mode to DVD-R, DVD-R DL, DVD-RW (DVD-Video format)  
(However, titles and Playlists (Video) cannot be copied in high speed mode to +R, +R DL, +RW)  
**+R DL**  is displayed, but copy cannot be performed.
-  Title with "One time only recording" restriction (⇒ 20, When recording the "One time only recording" broadcasts)
-  Titles deleted from the HDD by "One time only recording" restriction after copying. (⇒ 20, When recording the "One time only recording" broadcasts)
-  Title or Playlist (Video) contains still picture(s)  
● Still picture(s) cannot be copied.
-  (NTSC) Title or Playlist (Video) recorded using a different encoding system from that of the TV system currently selected on the unit.
-  (PAL) ● Titles and Playlists (Video) displaying these marks cannot be selected.

Data size of each registered item

**Size:**  
Data size recorded to the copy destination

- When copying at normal speed, the total data size will change according to the recording mode.
- The total data size shown may be larger than the sum of the data sizes for each registered item, because of data management information being written to the copy destination, etc.

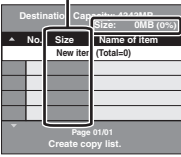

To play DVD-R, DVD-R DL, DVD-RW (DVD-Video format), +R and +R DL on other players, it is necessary to finalise them after copy.

**To edit the copying list**

Select the item in step 6-⑤ (⇒ 47)

- ① Press [OPTION].
- ② Press [▲, ▼] to select the operation and press [OK].

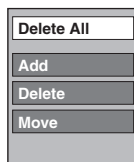

**Delete All:**

Delete all items registered on the copying list.  
Press [◀, ▶] to select "Yes" and press [OK].

**Add:**

Add new items to the copying list.

- 1 Press [▲, ▼, ◀, ▶] to select the title or Playlist (Video) and press [III].  
A check mark is displayed. Repeat this step until you select all necessary items.  
● Press [III] again to cancel.
- 2 Press [OK].

**Delete:**

Delete the selected items.  
Press [◀, ▶] to select "Yes" and press [OK].

**Move:**

Move selected items or change the order of items on the copying list.  
Press [▲, ▼] to select the destination and press [OK].

**To cancel all registered copying setting and lists**

After performing steps 1-3 (⇒ 47)

- 1 Press [▲, ▼] to select "Cancel All" and press [OK].
  - 2 Press [◀, ▶] to select "Yes" and press [OK].
- The settings and lists may be cancelled in the following situations.
    - When a title, still picture, etc. has been recorded or deleted at the copy source
    - When steps have been taken, for instance, to turn off the unit, open the tray, change the copy direction, etc.

**Copying a finalised DVD-R, DVD-R DL, DVD-RW (DVD-Video format), +R and +R DL**

DVD-V → HDD

You can copy the content of finalised DVD-R, DVD-R DL, DVD-RW (DVD-Video format), +R, and +R DL to the HDD and re-edit. While playing a disc, the content being played is copied to the HDD according to the set time.

- If you perform search, frame-by-frame or pause while copying, that portion of title is not recorded.
- When "Rec for High Speed Copy" (⇒ 61) is set to "On" and you make a copy, the copy will be made using the picture size selected in "Aspect for Recording" (⇒ 61) of the Setup menu.

**Operations and on screen displays during copy are also recorded.**

- Almost all DVD-Video on sale have been treated to prevent illegal copying, and cannot be copied.
- The following cannot be copied: Video CD, Audio CD and so on.

**Preparation**

- Insert the finalised disc (⇒ 15).

After performing steps 1-5 ("Format" is automatically set to "DVD-Video") (⇒ 47, Copying using the copying list-Advanced Copy)

**1 Set "Copy Time".**

- If you are not going to change the setting (⇒ step 2).
  - ① Press [▲, ▼] to select "Copy Time" and press [▶].
  - ② Press [▲, ▼] to select "Time Setting" and press [OK].
- Setting the unit to copy all the content on the disc
  - ③ Press [▲, ▼] to select "Off" and press [OK].
  - ④ Press [◀] to confirm.  
Copy will continue until there is not enough available recording space on the HDD.
- Setting the unit to copy according to the set time
  - ③ Press [▲, ▼] to select "On" and press [OK].
  - ④ Press [▲, ▼] to select "Copy Time" and press [OK].

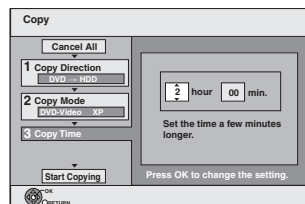

- ⑤ Press [◀, ▶] to select "hour" and "min." and press [▲, ▼] to set the recording time.
- ⑥ Press [OK].
- ⑦ Press [◀] to confirm.  
Copying to the HDD continues for the set time even after the content being played finishes.

- Set a few minutes longer than the source title, in order to include the operation time before play begins.
- You can also set the recording time with the numbered buttons.

**2 Press [▲, ▼] to select "Start Copying" and press [OK].**

**3 Press [◀, ▶] to select "Yes" and press [OK] to start copying.**

The disc top menu is displayed.

- Disc play automatically begins from title 1 when "Title 1" is selected from the "Auto-Play Select" menu when finalising the disc (⇒ 58).



#### 4 When the top menu is displayed

Press [**▲**, **▼**, **◀**, **▶**] to select the title you want to start copying, and press [**OK**].

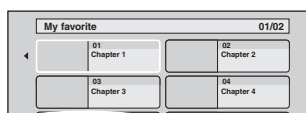

While playing in order, all the titles after the selected title are recorded until the set time. (After the last title on the disc has finished playing the top menu is recorded until the set time is reached.)

#### To return to the previous screen

Press [**RETURN** ↵].

#### To stop copying

Press [**■**].

You can also press and hold [**RETURN** ↵] for 3 seconds to stop copying.

- If stopped partway, copying will be up to that point.

#### Note

- The screen on the right is recorded at the beginning.
- The content is recorded as 1 title from the start of copy to the end.
- If play does not begin automatically or if the top menu does not display automatically, press [**▶**] (PLAY) to start.
- Even if you copy a high quality video/audio DVD, the original picture and audio quality cannot be exactly replicated.
- If you want to copy a title from a finalised DVD-RW (DVD Video Recording format), create a copy list and then copy (⇒ 47, Copying using the copying list—Advanced Copy).



## Copying Video (MPEG2) from a video equipment

Motion pictures encoded in the MPEG2 format, which have been taken by a Panasonic digital video camera with HDD etc, can be copied from the camera's HDD to this unit's HDD or DVD-RAM. (All the recordings on the same date become a title.)

- You cannot playback SD Video in the camera's HDD with this unit. You must copy the files to the HDD or a DVD-RAM.
- You cannot playback or record while copying SD Video.

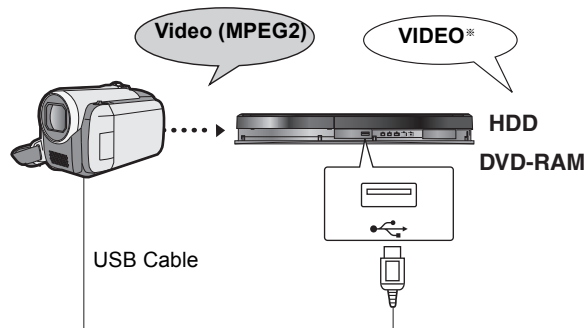

#### Preparation

- 1 Turn on both this unit and the camera.
  - 2 Connect the camera to this unit with USB cable.
  - 3 Select the appropriate mode that makes the camera ready for data transfer (such as "PC CONNECT") on the camera.
- Refer to the camera's operating instructions for detail.

The display automatically appears when you connect the camera to this unit. (⇒ 28)

- ① Press [**▲**, **▼**] to select "Video ( DivX & MPEG2 )" and press [**OK**].
- ② Press [**▲**, **▼**] to select "Copy Video ( MPEG2 )" and press [**OK**].

Then go to step 7 on page 47.

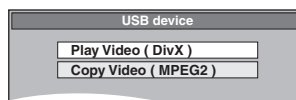

- SD Video on the camera are automatically registered on the copy list.
- If there are no SD Video on the camera, "Copy Video ( MPEG2 )" is not displayed.

# Copying still pictures/Playlist (Picture)

- You cannot copy pictures recorded to DVD-R, DVD-R DL or CD-R/CD-RW.
- When you copy a Playlist (Picture), it will become an album in the destination drive.

## Copying new still pictures on the USB memory—Copy New Pictures

USB → HDD

This unit saves information about imported still pictures. Therefore, if still pictures are imported from the same USB memory, then only new still pictures will be imported.

- 1 While stopped**  
**Insert the USB memory (⇒ 15).**  
The menu is automatically displayed. (⇒ 28)
- 2 Press [▲, ▼] to select “Picture ( JPEG )” and press [OK].**
- 3 Press [▲, ▼] to select “Copy New Pictures ( JPEG )” and press [OK].**

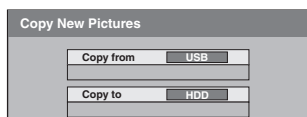

- 4 Press [◀, ▶] to select “Copy” and press [OK].**

### To stop copying

Press and hold [RETURN ↵] for 3 seconds.

### To return to the previous screen

Press [RETURN ↵].

### Note

- This unit saves the information on up to 12,000 still pictures and all USB memories for USB device. If additional still pictures are imported, then the older information will be deleted.
- If the space on the destination drive runs out or the number of files/folders to be copied exceeds the maximum (⇒ 14), copying will stop partway through.
- You cannot copy the information about the picture rotation.
- Still pictures copied from USB memories are grouped by the shooting date in the HDD.
- Only DCF-compliant USB media can be used for this function.

## Copying using the copying list

HDD → HDD -R (JPEG) RAM  
RAM → HDD RAM

- 1 While stopped**  
**Press [FUNCTION MENU].**
- 2 Press [▲, ▼] to select “Copy” and press [OK].**
- 3 Press [▲, ▼] to select “Advanced Copy” and press [OK].**

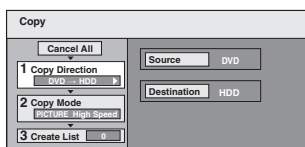

- If you are not going to change the registered list press [▼] several times (⇒ step 7).

- 4 Set the copy direction.**
  - If you are not going to change the copying direction, press [▼] (⇒ step 5).
  - ① Press [▲, ▼] to select “Copy Direction” and press [▶].
  - ② Press [▲, ▼] to select “Source” and press [OK].
  - ③ Press [▲, ▼] to select the drive and press [OK].
  - ④ Press [▲, ▼] to select “Destination” and press [OK].
  - ⑤ Press [▲, ▼] to select the drive and press [OK].  
The same drive as the copy source can be selected.
  - ⑥ Press [◀] to confirm.

## 5 Set the copy mode.

- If you are not going to change the recording mode, press [▼] (⇒ step 6).
- ① Press [▲, ▼] to select “Copy Mode” and press [▶].
- ② Press [▲, ▼] to select “Format” and press [OK].
- ③ Press [▲, ▼] to select “PICTURE” and press [OK].  
“Recording Mode” is automatically set to “High Speed”.
- ④ Press [◀] to confirm.

## 6 Register still pictures for copy.

- If you are going to copy a registered list without making any changes to it (⇒ step 7).

You can register still pictures, still picture folders or Playlists (Picture).

- Individual still pictures and folders/Playlists (Picture) cannot be registered on the same list.

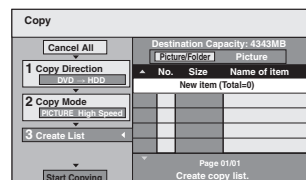

### ■ To register individual still pictures

- ① Press [▲, ▼] to select “Create List” and press [▶].
- ② Press [▲, ▼] to select “New item” and press [OK].
- ③ **HDD → HDD -R (JPEG) RAM**  
Press the “Green” button to select “PICTURE”  
Press the “Blue” button to select “Playlists”.
- ④ Press [▲, ▼, ◀, ▶] to select the still picture and press [■].  
A check mark is displayed. Repeat this step until you select all necessary items.
  - Press [■] again to cancel.
  - The items will be copied in the order of the copying list. If you want to specify the order, repeat selecting one item at a time.
  - When you switch between the “PICTURE” and “Playlists” tab, the check mark is cancelled.
- **To show other pages (⇒ 51)**
- **To select another folder or Playlist (Picture) (⇒ 51)**
- ⑤ Press [OK].
  - **To edit the copying list (⇒ 51)**
- ⑥ Press [◀] to confirm.

### ■ To register on a folder by folder basis (To register Playlists (Picture))

- ① Press [▲, ▼] to select “Create List” and press [▶].
- ② Press [▲, ▼] to select “Picture/Folder” and press [OK].



- ③ Press [▲, ▼] to select “Folder” and press [OK].
- ④ Press [▲, ▼] to select “New item” and press [OK].
- ⑤ **HDD → HDD -R (JPEG) RAM**  
Press the “Green” button to select “PICTURE”.  
Press the “Blue” button to select “Playlists”.
- ⑥ Press [▲, ▼] to select the folder or Playlist (Picture) and press [■].  
A check mark is displayed. Repeat this step until you select all necessary items.
  - Press [■] again to cancel.
  - The items will be copied in the order of the copying list. If you want to specify the order, repeat selecting one item at a time.
- **To show other pages (⇒ 51)**
- ⑦ Press [OK].
- ⑧ Repeat steps ④–⑦ until you select all necessary folders (Playlists (Picture)).
  - **To edit the copying list (⇒ 51)**
- ⑨ Press [◀] to confirm.

## 7 Press [▲, ▼] to select “Start Copying” and press [OK].

- Only when copying individual still pictures. When specifying another folder as the copying destination, select “Folder”.

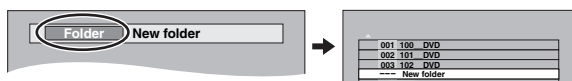

## 8 Press [◀, ▶] to select “Yes” and press [OK] to start copying.

## 9 For copy to DVD-R

Press [◀, ▶] to select “Copy & Finalise” or “Copy Only” and press [OK].

### To stop copying

Press and hold [RETURN ↵] for 3 seconds.

### To return to the previous screen

Press [RETURN ↵].

### Note

- The sequence in which the still pictures are registered on the copy list may not be the same at the copy destination.
- If the space on the destination drive runs out or the number of files/folders to be copied exceeds the maximum (⇒ 14), copying will stop partway through.
- You cannot copy the information about the picture rotation.
- **[R]** Video cannot be copied to a disc with still pictures (JPEG) already recorded on it.
- **[R]** Still images cannot be copied to a DVD-R disc with video already recorded on it.

### To show other pages

Press [▲, ▼, ▶, ◀] to select “Previous” or “Next” and press [OK].

- You can also press [◀◀, ▶▶] to show other pages.

### ■ To edit the copying list

Select the item in step 6–⑤ (for a still picture) or 6–⑦ (for a folder or Playlist) (⇒ 50)

① Press [OPTION].

② Press [▲, ▼] to select the operation and press [OK].

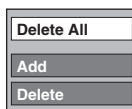

#### Delete All:

Delete all items registered on the copying list. Press [◀, ▶] to select “Yes” and press [OK].

#### Add:

Add new items to the copying list.

1 Press [▲, ▼, ▶, ◀] to select the still picture or folder and press [■].

A check mark is displayed. Repeat this step until you select all necessary items.

- Press [■] again to cancel.

2 Press [OK].

#### Delete:

Delete the selected items.

Press [◀, ▶] to select “Yes” and press [OK].

### To cancel all registered copying settings and lists

After performing steps 1–3 (⇒ 50, Copying using the copying list)

1 Press [▲, ▼] to select “Cancel All” and press [OK].

2 Press [◀, ▶] to select “Yes” and press [OK].

- The settings and lists may be cancelled in the following situations.
  - When a title, Playlist (Picture) or still picture has been recorded or deleted at the copy source
  - When steps have been taken, for instance, to turn off the unit, open the tray, change the copy direction, etc.

### ■ To select another folder or Playlist (Picture)

After performing step 6–② (⇒ 50, To register individual still pictures)

① **[HDD] → [HDD] [R] (JPEG) [RAM]**

Press the “Green” button to select “PICTURE”.

Press the “Blue” button to select “Playlists”.

② Press [▲, ▼, ▶, ◀] to select “Folder” and press [OK].

③ Press [▲, ▼] to select the folder or Playlist (Picture) and press [OK].

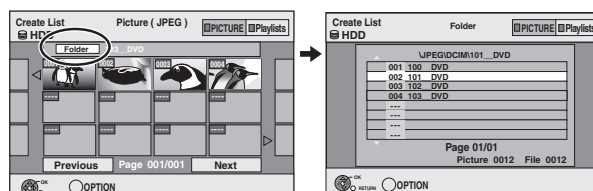

You can also select folders with the numbered buttons.

- Individual still pictures of different folders (Playlists (Picture)) cannot be registered on the same list.
- It is convenient to create a Playlist (Picture) (⇒ 42) if you want to register still pictures of different folders on HDD in the same list.

## Copying still pictures on the USB memory

### Copying all the still pictures

**USB → HDD**

1

While stopped

Insert the USB memory (⇒ 15).

The menu is automatically displayed. (⇒ 28)

2

Press [▲, ▼] to select

“Picture ( JPEG )” and press [OK].

3

Press [▲, ▼] to select “Copy All Pictures ( JPEG )” and press [OK].

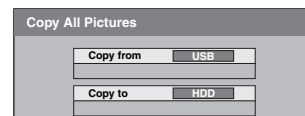

4

Press [◀, ▶] to select “Copy” and press [OK].

### Copying using the copying list

**USB → HDD RAM**

1

While stopped

Insert the USB memory (⇒ 15).

The menu is automatically displayed. (⇒ 28)

2

Press [▲, ▼] to select

“Picture ( JPEG )” and press [OK].

3

Press [▲, ▼] to select “Copy Selected Pictures ( JPEG )” and press [OK].

4

Perform steps 4 – 8 on “Copying using the copying list” (⇒ 50).

- Another folder cannot be selected as the copying destination on step 7.

### To stop copying

Press and hold [RETURN ↵] for 3 seconds.

### Note

- Copy Mode is fixed at “PICTURE High Speed”.
- The structure of folders on the USB memory may not be the same at the copy destination.
- If the space on the destination drive runs out or the number of files/folders to be copied exceeds the maximum (⇒ 14), copying will stop partway through.
- You cannot copy the information about the picture rotation.
- Still pictures copied from USB memories are grouped by the shooting date in the HDD or DVD-RAM.

You can store the following formats of music data in this unit's HDD.

- Music CD (CD-DA)
- MP3

You can copy MP3 files from the USB memory or CD-R/CD-RW/DVD-R/DVD-R DL.

## Copying music from a CD

**CD** → **HDD**

All tracks on the music CD (CD-DA) are recorded on the HDD. (Cannot record track-by-track.)

- One CD is recorded on the HDD as one album.
- Audio quality: LPCM
- The maximum number of albums on HDD: 300 (Depends on the remaining capacity.)  
If titles or pictures are recorded, then the number of albums that can be recorded will be reduced.

### Preparation

Press [DRIVE SELECT] to select the DVD drive.

## 1 Insert a music CD.

The menu is automatically displayed.

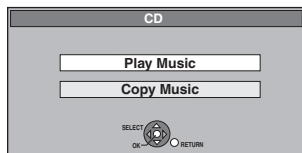

## 2 Press [▲, ▼] to select “Copy Music” and press [OK].

## 3 Press [◀, ▶] to select “Copy” and press [OK].

Recording starts.

### To stop recording

Press and hold [RETURN ↵] for 3 seconds.

- If the recording is cancelled, then no tracks on the CD will be recorded.

### To return to the previous screen

Press [RETURN ↵].

### Note

- While recording, no other operations can be performed. Timer recordings will not proceed.
- Tracks recorded on the HDD cannot be transferred to a disc or USB memory.
- CDs which have SCMS (Serial Copy Management System) restrictions cannot be recorded to the HDD.

## Copying music from a USB memory or CD-R/CD-RW/DVD-R/DVD-R DL

**-R -R DL CD USB (MP3) → HDD**

You can copy MP3 files recorded on USB memory or CD-R/CD-RW/DVD-R/DVD-R DL to the HDD by file or folder.

- One folder is recorded on the HDD as one group.
- The maximum number of albums\* on HDD: 300  
The maximum number of tracks on HDD: 3000 (Depends on the remaining capacity.)  
If titles or pictures are recorded, then the number of albums\* that can be recorded will be reduced.

\* Folders with music files (groups) copied to the HDD will be treated as albums.

## 1 While stopped

**-R -R DL CD**

Insert the CD-R/CD-RW/DVD-R/DVD-R DL (⇒ 15).

**USB**

Insert the USB memory (⇒ 15).

The menu is automatically displayed. (⇒ 28)

## 2 Press [▲, ▼] to select “Copy Music (MP3)” and press [OK].

“Copy Direction” and “Copy Mode” are automatically set to “USB→HDD”, “DVD→HDD” or “CD→HDD” and “MUSIC High Speed”, respectively.

## 3 Register MP3 files for copy.

You can register MP3 files or folders.

- MP3 files and folders cannot be registered on the same list.

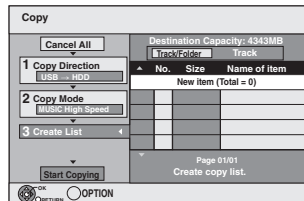

### ■ To register individual MP3 files

- 1 Press [▲, ▼] to select “Create List” and press [▶].
- 2 Press [▲, ▼] to select “New item” and press [OK].
- 3 Press [▲, ▼] to select the folder and press [OK].
- 4 Press [▲, ▼] to select the MP3 file and press [■].

A check mark is displayed. Repeat this step until you select all necessary items.

- Press [■] again to cancel.

• The items will be copied in the order of the copying list. If you want to specify the order, repeat selecting one item at a time.

- 5 Press [OK].

- To edit the copying list (⇒ 53)

- 6 Press [◀] to confirm.

## ■ To register on a folder by folder basis

- ① Press [▲, ▼] to select “Create List” and press [▶].
- ② Press [▲, ▼] to select “Track / Folder” and press [OK].



- ③ Press [▲, ▼] to select “Folder” and press [OK].
- ④ Press [▲, ▼] to select “New item” and press [OK].
- ⑤ Press [▲, ▼] to select the folder and press [■].  
A check mark is displayed. Repeat this step until you select all necessary items.
  - Press [■] again to cancel.
  - The items will be copied in the order of the copying list. If you want to specify the order, repeat selecting one item at a time.
- ⑥ Press [OK].
  - To edit the copying list (⇒ below)
- ⑦ Press [◀] to confirm.

## 4 Press [▲, ▼] to select “Start Copying” and press [OK].

- For individual files only

### When specifying an existing folder as the copying destination

- ① Press [▲, ▼] to select “Folder” and press [OK].
- ② Press [▲, ▼] to select the folder and press [OK].

### When creating a new folder as the copying destination

- ① Press [◀, ▶] to select “Yes” and press [OK].
- ② Enter the folder name (⇒ 44, Entering text).

## 5 Press [◀, ▶] to select “Yes” and press [OK] to start copying.

### To stop copying

Press and hold [RETURN ↵] for 3 seconds.

### To return to the previous screen

Press [RETURN ↵].

### Note

- The sequence in which the MP3 files are registered on the copy list may not be the same at the copy destination.
- If MP3 files are already contained inside the copy destination folder, the new MP3 files are recorded following the existing MP3 files.
- If the space on the destination drive runs out or the number of files/folders to be copied exceeds the maximum (⇒ 14), copying will stop partway through.

## ■ To edit the copying list

Select the item in step 3–⑤ (for a MP3 file) (⇒ 52, Copying music from a USB memory or CD-R/CD-RW/DVD-R/DVD-R DL) or 3–⑥ (for a folder) (⇒ above).

- ① Press [OPTION].
- ② Press [▲, ▼] to select the operation and press [OK].



### Delete All:

Delete all items registered on the copying list.  
Press [◀, ▶] to select “Yes” and press [OK].

### Add:

Add new items to the copying list.

- 1 Press [▲, ▼] to select the MP3 file or folder and press [■].  
A check mark is displayed. Repeat this step until you select all necessary items.
  - Press [■] again to cancel.
- 2 Press [OK].

### Delete:

Delete the selected items.  
Press [◀, ▶] to select “Yes” and press [OK].

### To cancel all registered copying settings and lists

After performing steps 1–2 (⇒ 52, Copying music from a USB memory or CD-R/CD-RW/DVD-R/DVD-R DL)

- 1 Press [▲, ▼] to select “Cancel All” and press [OK].
- 2 Press [◀, ▶] to select “Yes” and press [OK].

## Using on-screen menus

### Common procedures

#### 1 Press [DISPLAY].

Disc	Soundtrack	1	Digital 2/0 ch
Play	Subtitles	Off	
Picture	Audio channel	L R	
Sound			
Other			
Menu	Item	Setting	

- Depending on the condition of the unit (playing, stopped, etc.) and disc contents, there are some items that you cannot select or change.

#### 2 Press [▲, ▼] to select the menu and press [▶].

#### 3 Press [▲, ▼] to select the item and press [▶].

#### 4 Press [▲, ▼] to select the setting.

- Some items can be changed by pressing [OK].

### To clear the on-screen menus

Press [DISPLAY].

### Disc menu—Setting the disc content

#### Soundtrack\*

**HDD** **RAM** **-R** **-R DL** **-RW(V)** **+R** **+R DL** **+RW** **-RW(VR)**

The disc's audio attributes appear.

#### DVD-V

Select the audio and language (⇒ right, Audio attribute, Language).

#### VCD (SVCD) and DivX

Select the soundtrack number.

- Soundtrack numbers are displayed even when there is only one audio type.

#### Subtitles\*

#### DVD-V

Turn the subtitle on/off and select the language (⇒ right, Language).

**HDD** **RAM** **-R** **-R DL** **-RW(V)** **+R** **+R DL** **+RW** **-RW(VR)** (Only discs that contain subtitle on/off information)

Turn the subtitle on/off.

- Subtitle on/off information cannot be recorded using this unit.

#### VCD (SVCD) and DivX

Turn the subtitle on/off and select "Text" or the subtitle number.

- "Text" or subtitle numbers are displayed even if there are not multiple subtitles.

#### Angle\* DVD-V

Change the number to select an angle.

#### Audio channel HDD RAM -RW(VR) VCD and DivX

(⇒ 26, Changing audio during play)

#### Source Select (DivX)

- Automatic:**  
The constructing method of the DivX contents is automatically distinguished and output.
- Interlace:**  
Select when the disc contents were recorded using interlace.
- Progressive:**  
Select when the disc contents were recorded using progressive.

#### PBC (Playback control ⇒ 78) VCD

Indicates whether menu play (playback control) is on or off.

\* With some discs, you may only be able to make changes using the menus (⇒ 17) on the disc.

- The display changes according to the disc content. You cannot change when there is no recording.

### Audio attribute

LPCM/Digital/DTS/MPEG:

Signal type

k (kHz):

Sampling frequency

b (bit):

Number of bits

ch (channel):

Number of channels

### Language

ENG: English	DAN: Danish	THA: Thai
FRA: French	POR: Portuguese	POL: Polish
DEU: German	RUS: Russian	CES: Czech
ITA: Italian	JPN: Japanese	SLK: Slovak
ESP: Spanish	CHI: Chinese	HUN: Hungarian
NLD: Dutch	KOR: Korean	FIN: Finnish
SVE: Swedish	MAL: Malay	*: Others
NOR: Norwegian	VIE: Vietnamese	

### Play menu—Change the play sequence

This function works only when the elapsed play time is displayed. Select the item for repeat play. Depending on the disc, the items that can be selected will differ.

#### Repeat Play

- All **CD** **VCD**
- Chapter **HDD** **RAM** **-R** **-R DL** **-RW(V)** **+R** **+R DL** **+RW** **DVD-V** **-RW(VR)**
- Group **MP3 (except USB)**
- PL (Playlist (Video)) **HDD** **RAM** **-RW(VR)**
- Title **HDD** **RAM** **-R** **-R DL** **-RW(V)** **+R** **+R DL** **+RW** **DVD-V** **-RW(VR)**
- Track **CD** **VCD** and **MP3 (except USB)**

Select "Off" to cancel.

### Picture menu—Change the picture quality

#### Playback NR

Reduces noise and picture degradation while playing.

- On:**  
Reduces noise and picture degradation.
- Off:**  
Video is played back as it is.

#### Input NR

Reduces the noise while recording.

- Automatic:**  
Noise reduction only works on picture input from a video tape.
- On:**  
Noise reduction works for input video.
- Off:**  
Noise reduction is off. You can record the input signal as it is.

## Sound menu—Change the DVB multi audio and sound effect

### DVB Multi Audio

If more than one audio channel is output, you can set the desired channel before recording.

- DVB Multi Audio cannot be selected during playback or recording.
- Depending on the broadcast, the items that can be selected will differ.
  - English
  - Italian
  - Spanish
  - Basque
  - Corsican
  - German
  - French
  - Catalan
  - Galician
  - Original\*

\* "Original" is displayed when the original language is available in a broadcast.

### Dialogue Enhancer

**HDD** **RAM** **-R** **-R DL** **-RW(V)** **+R** **+R DL** **+RW** **DVD-V**

**-RW(VR)** and **DivX**

(Dolby Digital, 3-channel or over only, including a centre channel)  
The volume of the centre channel is raised to make dialogue easier to hear.

## Other menu—Change the DVB subtitle and display position

### DVB Subtitles

You can set the desired subtitles if more than one subtitle track can be selected.

- DVB Subtitles cannot be selected during playback or recording.
- Depending on the broadcast, the items that can be selected will differ.
  - English
  - Italian
  - Spanish
  - Basque
  - Corsican
  - German
  - French
  - Catalan
  - Galician
  - Original\*

\* "Original" is displayed when the original language is available in a broadcast.

### Position

1–5:

The higher the setting the lower the on-screen menu moves.

## Status messages

Press **[STATUS ⓘ]**.

The display changes each time you press the button.

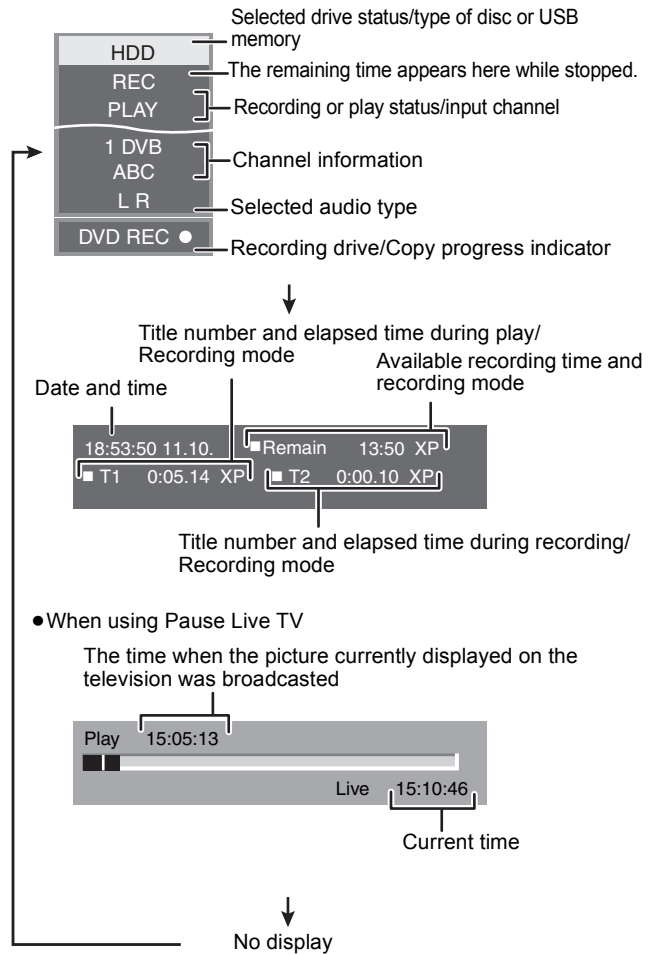

HDD RAM -R -R DL -RW(V) +R +R DL +RW -RW(VR)

## Common procedures

### Preparation

- Press [DRIVE SELECT] to select the drive.

- 1 While stopped  
Press [FUNCTION MENU].
- 2 Press [▲, ▼] to select “Others” and press [OK].

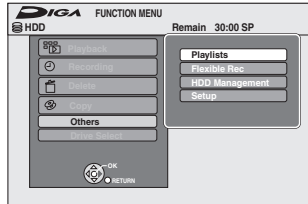

- 3 Press [▲, ▼] to select “HDD Management” or “DVD Management” and press [OK].

e.g., **RAM**

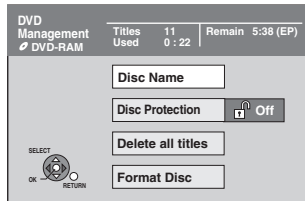

- When HDD has been selected, “Delete all titles” and “Format HDD” are displayed.

## Setting the protection

### RAM

#### Preparation

- Press [DRIVE SELECT] to select the DVD drive.

After performing steps 1–3 (⇒ left)

- 1 Press [▲, ▼] to select “Disc Protection” and press [OK].
- 2 Press [◀, ▶] to select “Yes” and press [OK].

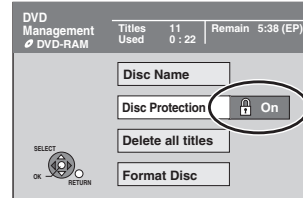

The lock symbol appears closed when the disc is write-protected.

#### To return to the previous screen

Press [RETURN ↵].

#### To exit the screen

Press [EXIT].



## Deleting all titles and Playlists (Video)—Delete all titles

**HDD** **RAM**

### Preparation

- Press [DRIVE SELECT] to select the HDD or DVD drive.
- **RAM** Release protection (⇒ 56, Setting the protection).

After performing steps 1–3 (⇒ 56, Common procedures)

- 1 Press [**▲**, **▼**] to select “Delete all titles” and press [OK].
- 2 Press [**◀**, **▶**] to select “Yes” and press [OK].
- 3 Press [**◀**, **▶**] to select “Start” and press [OK].  
A message appears when finished.
- 4 Press [OK].

### To return to the previous screen

Press [RETURN ↵].

### To exit the screen

Press [EXIT].

### Note

- Once deleted, the recorded contents are lost and cannot be restored. Make certain before proceeding.
- Deleting all video titles will result in all Playlists (Video) also being deleted.
- Still picture data (JPEG), Playlists (Picture), music data or computer data cannot be deleted.
- Delete does not work if one or more titles are protected.

## Providing a name for a disc

**RAM** **-R** **-R DL** **-RW(V)** **+R** **+R DL** **+RW**

You can provide a name for each disc.

### Preparation

- Press [DRIVE SELECT] to select the DVD drive.
- **RAM** Release protection (⇒ 56, Setting the protection).

After performing steps 1–3 (⇒ 56, Common procedures)

- 1 Press [**▲**, **▼**] to select “Disc Name” and press [OK].

(⇒ 44, Entering text)

- The disc name is displayed in the DVD Management window.
- **-R** **-R DL** **-RW(V)** **+R** **+R DL** With a finalised disc, the name is displayed on the Top Menu.
- **+RW** The disc name is displayed only if you play the disc on other equipment after creating top menu.



### Note

- Once a name is provided to a disc, it is not possible to record still images to that disc.

### To return to the previous screen

Press [RETURN ↵].

### To exit the screen

Press [EXIT].

## Deleting all the contents—Format

**HDD** **RAM** **-RW(V)** **+RW** **-RW(VR)**

**+R** **+R DL** (New disc only)

### Preparation

- Press [DRIVE SELECT] to select the HDD or DVD drive.

Formatting deletes all contents (including computer data), and they cannot be restored. Check carefully before proceeding. The contents are deleted when you format a disc even if you have set protection.

After performing steps 1–3 (⇒ 56, Common procedures)

- 1 Press [**▲**, **▼**] to select “Format HDD” or “Format Disc” and press [OK].
- 2 Press [**◀**, **▶**] to select “Yes” and press [OK].
- 3 Press [**◀**, **▶**] to select “Start” and press [OK].

A message appears when formatting is finished.

### Note

- Formatting normally takes a few minutes; however, it may take up to a maximum of 70 minutes (**RAM**).
- Do not disconnect the AC mains lead while formatting. This can render the disc unusable.

- 4 Press [OK].

### Note

- When a disc has been formatted using this unit, it may not be possible to use it on any other equipment.
- **-R** **-R DL** **CD** Formatting cannot be performed.
- You can format DVD-RW only as DVD-Video format on this unit.
- Sample pictures are restored when formatting HDD even if they have been deleted.

### To return to the previous screen

Press [RETURN ↵].

### To exit the screen

Press [EXIT].

## Selecting the background style—Top Menu

**-R -R DL -RW(V) +R +R DL +RW**

You can select the background that will be displayed as the DVD-Video top menu after finalising or creating Top Menu (**+RW**).

### Preparation

Press [DRIVE SELECT] to select the DVD drive.

After performing steps 1–3 (⇒ 56, Common procedures)

- 1 Press [**▲**, **▼**] to select “Top Menu” and press [OK].
- 2 Press [**▲**, **▼**, **◀**, **▶**] to select the background and press [OK].

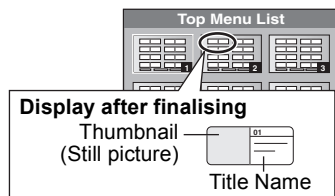

- You can change thumbnails displayed in the top menu. (⇒ 37, Change Thumbnail)
- **-R** This function cannot be used for discs with still images recorded on them.

## Selecting whether to show the Top Menu first—Auto-Play Select

**-R -R DL -RW(V) +R +R DL +RW**

You can select whether to show the top menu after finalising.

### Preparation

Press [DRIVE SELECT] to select the DVD drive.

After performing steps 1–3 (⇒ 56, Common procedures)

- 1 Press [**▲**, **▼**] to select “Auto-Play Select” and press [OK].
- 2 Press [**▲**, **▼**] to select “Top Menu” or “Title 1” and press [OK].

Top Menu: The top menu appears first.

Title 1: The disc content is played without displaying the top menu.

- **-R** This function cannot be used for discs with still images recorded on them.

## Enabling discs to be played on other equipment—Finalise

**-R -R DL -RW(V) +R +R DL**

Make selections from “Top Menu” and “Auto-Play Select” (⇒ above) before finalising the disc.

### Preparation

Press [DRIVE SELECT] to select the DVD drive.

After performing steps 1–3 (⇒ 56, Common procedures)

- 1 Press [**▲**, **▼**] to select “Finalise” and press [OK].
- 2 Press [**◀**, **▶**] to select “Yes” and press [OK].
- 3 Press [**◀**, **▶**] to select “Start” and press [OK].

A message appears when finalising is finished.

### Note

- You cannot cancel finalising.
- Finalising takes up to 15 minutes.  
(**-R DL +R DL** Finalising takes up to 60 minutes.)
- Do not disconnect the AC mains lead while finalising.  
This will render the disc unusable.

- 4 Press [OK].

### Note

When finalising a high-speed recording compatible disc, it may take longer than displayed on the confirmation screen (approximately four times).

### After finalising

- **-R -R DL +R +R DL** The disc becomes play-only and you can no longer record or edit.
  - **-RW(V)** You can record and edit the disc after formatting (⇒ 57) although it becomes play-only after finalising.
  - When copying in high speed, chapters will be replicated.
  - **-R -RW(V) +R** Chapters are created automatically (**-R -RW(V)**: about 5-minute chapters/**+R**: about 8-minute chapters), if\*
    - the titles were directly recorded to the disc.
    - the titles were copied using any mode other than the high speed mode.
- \* This time varies greatly depending on the condition and mode of recording.
- There is a pause of several seconds between titles and chapters during play.

	Before finalising	After finalising
Recording/Editing/Entering name	○	–
Play on other players	–	○

- You cannot finalise discs recorded on other manufacturer's equipment.
- If you finalise discs recorded on Panasonic equipment other than this unit, the background selected as “Top Menu” may not be displayed.
- Discs finalised on this unit may not be playable on other players due to the condition of the recording.

Visit Panasonic's homepage for more information about DVDs.

<http://www.panasonic-europe.com>

## Creating Top Menu—Create Top Menu

**+RW**

+RW discs contain no Top Menu data. Top Menu is a convenient function. We recommend you create the menu before playing a +RW disc on other equipment.

You cannot use the Top Menu for playing on this unit.

Make selections from “Top Menu” and “Auto-Play Select” (⇒ left) before creating top menu.

### Preparation

Press [DRIVE SELECT] to select the DVD drive.

After performing steps 1–3 (⇒ 56, Common procedures)

- 1 Press [**▲**, **▼**] to select “Create Top Menu” and press [OK].
- 2 Press [**◀**, **▶**] to select “Yes” and press [OK].
- 3 Press [**◀**, **▶**] to select “Start” and press [OK].  
Creating Top Menu starts. You cannot cancel creating. Creating Top Menu can take a few minutes.
- 4 Press [OK].

### Note

- You can record or edit discs after creating the Top Menu. But the created menu is deleted when you record or edit disc. In such cases, create the Top Menu again by using “Create Top Menu”.

### To return to the previous screen

Press [RETURN ↵].

### To exit the screen

Press [EXIT].

# Changing the unit's settings

You can change the unit's settings using Setup menu.

- The settings remain intact even if you switch the unit to standby.

## Common procedures

- 1 While stopped**  
Press [FUNCTION MENU].
  - 2 Press [▲, ▼] to select "Others" and press [OK].**
  - 3 Press [▲, ▼] to select "Setup" and press [OK].**
- 
- 4 Press [▲, ▼] to select the tab and press [▶].**
  - 5 Press [▲, ▼] to select the menu and press [OK].**
  - 6 Press [▲, ▼] to select the option and press [OK].**

**To return to the previous screen**

Press [RETURN ↵].

**To exit the screen**

Press [EXIT].

## Tuning

(All factory default settings are indicated with underlined text.)

### ■ Favourites Edit

You can create four Favourites of channels for making viewing and recording easier. Editing these Favourites does not affect the channel setting itself.

- Timer recording may not work correctly if you edit the Favourite during timer recording standby.

**Press the "Green" button to select the Favourite.**

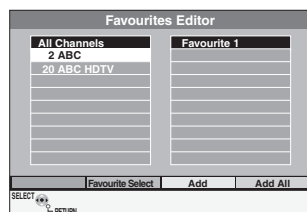

**To add channels to a Favourite**

- Press [▲, ▼] to select the channel in the "All Channels" column and press the "Yellow" button.
  - Repeat this step to add other channels.
  - Press the "Blue" button to add all the available channels to the Favourite. (This function is available only when no channels have been added to the Favourite.)
- Press [OK] to save the Favourite.

**To change the order of channels of a Favourite**

- Press [▶]\*.
- Press [▲, ▼] to select the channel in the "Favourite" column to move and press the "Green" button.
- Press [▲, ▼] to select the new position of the channel and press the "Green" button.
  - Repeat the steps ② – ③ to move other channels.
- Press [OK] to save the Favourite.

**To delete channels on a Favourite**

- Press [▶]\*.
- Press [▲, ▼] to select the channel in the "Favourite" column and press the "Yellow" button.
  - Repeat this step to delete other channels.
  - Press the "Blue" button to delete all the channels from the Favourite.

- Press [OK] to save the Favourite.  
Deleting a channel from a Favourite does not affect the channel itself. You can still select the channel from the "All Channels" category.

**To change the name of a Favourite in the "Favourite" column**

- Press [▶]\*.
- Press the "Red" button.  
(⇒ 44, Entering text)

\* When the station name of the "All Channels" column is highlighted

### ■ Auto Setup Restart Download from TV

You can restart auto channel setting if set up (⇒ 10) fails for some reason.

Select "Download from TV" when you connect the unit to a Q Link compatible TV with a fully wired 21-pin Scart cable or a VIERA Link (HDAVI Control 3 or later) compatible TV with an HDMI cable.

When the confirmation screen appears

**Press [◀, ▶] to select "Yes" and press [OK].**

You can also use the following method to restart Auto Setup.

When the unit is on and stopped

**Press and hold [▼ CH] and [CH ▲] on the main unit until the Country setting screen appears.**

All the settings except for the ratings level, ratings PIN, clock settings and remote control code, etc. return to the factory preset. The timer recording programmes are also cancelled.

### ■ DVB Manual Tuning

You can set channels manually that the DVB Auto Setup could not complete successfully.

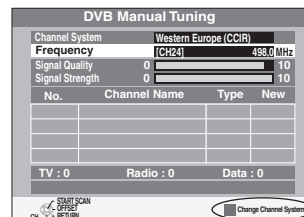

If there is no signal quality and/or signal strength, press the "Red" button and select the correct channel system.

- Press [▲, ▼] to select the channel you want to set.
- Press [◀, ▶] to adjust the frequency.
  - The frequency rises and falls in steps of 0.5 MHz.
  - Adjust the frequency by checking the signal strength and signal quality displays.  
[Refer to "Signal Condition" (⇒ 60) for signal quality and signal strength.]
- Press [OK] to start scan.  
The set channel is displayed in the table.
- Press [EXIT] and press [▲, ▼ CH] to check that applicable channels have been selected.

### ■ Add New DVB Channels

You can search for newly added terrestrial digital channels to receive.

The unit starts searching for newly available terrestrial digital channels. This takes about 5 minutes.

A message is displayed when the search is finished.

"No new DVB channels found." is displayed when no new channels can be found.

Press [OK] to save the newly found channels.

### ■ New Channel Message (⇒ 16)

When a new DVB channel is added this unit will be informed automatically. Then the confirmation message appears. If you select "Yes" on the display, Auto-Setup starts (all channel settings are deleted. The timer recording programmes are also cancelled.)

[Automatic]

[Off]

The Channel Messages are not shown.

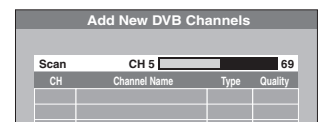

## ■ Signal Condition

You can check the quality and strength of digital broadcast signals.

The quality and strength of the signal are shown.

Press [ $\wedge$   $\vee$  CH] to select the channel.

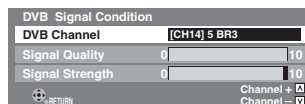

When "Signal Condition" is displayed in grey and cannot be selected:

- 1 Press [EXIT] to exit the screen.
- 2 Press [ $\wedge$   $\vee$  CH] to select a digital channel. "D" appears on the unit's display.
- 3 Display the Setup menu again ( $\Rightarrow$  59).

### Signal Quality

Below 2 (display red):

The signal quality is so poor that there may be interference in the pictures and sound.

2–5 (display orange):

The signal quality is basically adequate, but brief interference in the pictures and sound is possible in isolated case.

Over 5 (display green):

Optimum picture and sound quality.

### Signal Strength

The display for signal strength is grey. "0" means signal strength 0%, "10" means signal strength 100%.

If the signal is too strong, the display will change from grey to red.

Reduce the signal amplification at your aerial.

● When the signal is weak:

- adjust the aerial reception with "DVB Manual Tuning" in the Setup menu ( $\Rightarrow$  59).
- check that the current digital broadcast channel is correctly broadcasting.

## ■ DVB Preferred Language

You can select up to 2 different subtitles and audio tracks to be used when audio and subtitles of digital broadcasts are received. Select the order of priority.

If the selected language is not available, then the language included in the broadcast programme is selected.

### Multi Audio

#### Multi Audio ( alternative )

[English]	[German]	[Italian]	[French]
[Spanish]	[Catalan]	[Basque]	[Galician]
[Corsican]	[Original]*		

### Subtitles

#### Subtitles ( alternative )

[English]	[German]	[Italian]	[French]
[Spanish]	[Catalan]	[Basque]	[Galician]
[Corsican]	[Original]*		

\* The language specified as "Original" by the broadcast channel.

## Disc

(All factory default settings are indicated with underlined text.)

### Settings for Playback

- Press [OK] to show the following settings.

#### Ratings

Set a ratings level to limit DVD-Video play. Follow the on-screen instructions. Enter a 4-digit PIN with the numbered buttons when the PIN screen is shown.

##### Do not forget your PIN.

Setting ratings (When level 8 is selected)

- [8 No Limit] All DVD-Video can be played.  
[1 to 7] Prohibits play of DVD-Video with corresponding ratings recorded on them.  
[0 Lock All] Prohibits play of all DVD-Video.

- Changing settings (When level 0 to 7 is selected)

- [Unlock Recorder] [Change PIN]  
[Change Level] [Temporary Unlock]

#### Soundtrack

- [English] [German] [French] [Italian]  
[Spanish] [Dutch] [Swedish]  
[Original] The original language of each disc will be selected.

[Other \* \* \* \* \*]\*

#### Subtitles

[Automatic] If the language selected for "Soundtrack" is not available, subtitles of that language will automatically appear if available on that disc.

- [English] [German] [French] [Italian]  
[Spanish] [Dutch] [Swedish]

[Other \* \* \* \* \*]\*

#### Menus

- [English] [German] [French] [Italian]  
[Spanish] [Dutch] [Swedish]

[Other \* \* \* \* \*]\*

\* [Other \* \* \* \* \*]

Enter a code (⇒ 69) with the numbered buttons. When the selected language is not available on the disc, the default language is played. There are discs where you can only switch the language from the menu screen (⇒ 17).

#### DVD-V

- Choose the language for audio, subtitle and disc menus.
- Some discs start in a certain language despite any changes you make here.
- In case of English/French/German/Italian/Spanish languages, when you make download from TV, or Country setting of Auto-Setup, the language ("Soundtrack"/"Menus") will be same and "Subtitles" will set to "Automatic".

### Settings for Recording

- Press [OK] to show the following settings.

#### Recording time in EP mode

Select the maximum number of hours for recording in EP mode (⇒ 21, Recording modes and approximate recording times).

- [EP ( 6 hours )] You can record for 6 hours on an unused 4.7 GB disc.  
[EP ( 8 hours )] You can record for 8 hours on an unused 4.7 GB disc.

- The sound quality is better when using "EP ( 6 hours )" than when using "EP ( 8 hours )".

#### Aspect for Recording

Sets the aspect ratio when recording or copying.

[Automatic] The programme will be recorded in the original aspect used when recording started (including when recording started at a commercial, etc.).

[16:9] [4:3]

- When recording or copying to the HDD or DVD-RAM with "Rec for High Speed Copy" set to "Off", programme will be recorded in the original aspect ratio.
- In the following cases, even when set to "Automatic" or "16:9", recordings will be made or copied in 4:3.
  - [R] [R DL] [RW(V)] When the recording mode is set to "EP" or "FR (recordings 5 hours or longer)" mode.
  - When recording or copying to a +R, +R DL and +RW. High-speed copy does not work for the titles recorded in 16:9 even if they were recorded with "Rec for High Speed Copy" set to "On"

### Chapter Creation

Set the automatic Chapter Creation method. (⇒ 36)

[Automatic] [5 minutes]

[Off] No chapter start points are set.

### Rec for High Speed Copy

You can copy recorded titles from the HDD to DVD-R, DVD-R DL, DVD-RW (DVD-Video format), +R, +R DL and +RW using high speed mode. However, aspect, etc. is restricted (⇒ below). We recommend turning the setting "Off" if high speed copy to DVD-R, etc. is not necessary when recording a programme. This setting is effective when recording from a television programme or external equipment, or when copying from a finalised DVD-Video disc.

- [On] You can high-speed copy to DVD-R, etc. Press [◀, ▶] to select "Yes" and press [OK].
- The following restrictions are applied to recorded titles.
    - Recordings are made using the aspect ratio set in "Aspect for Recording" (⇒ left).
    - You are no longer able to switch the audio when watching a programme on an input channel on the TV connected to this unit (e.g., AV1, etc).

[Off]

### DVD Speed for High Speed Copy

Select the speed of high-speed copying (When using high-speed copy compatible DVD-RAM 5X, DVD-R, +R 8X or +RW 4X discs).

[Maximum]

[Normal ( Silent )] The noise generated by this unit is less than when "Maximum" is selected, however the time required for copying will double (approximately).

## Picture

(All factory default settings are indicated with underlined text.)

### Comb Filter

Select the picture sharpness when recording. The setting is fixed with "On" if you set "TV System" to "NTSC" (⇒ 63).

- [On] Pictures become clear and vivid. Normally, use this setting.  
[Off] Select it when recording noisy pictures.

### Still Mode

Select the type of picture shown when you pause play (⇒ 78, Frames and fields).

[Automatic]

- [Field] Select if jittering occurs when "Automatic" is selected. (The picture is coarser.)  
[Frame] Select if small text or fine patterns cannot be seen clearly when "Automatic" is selected. (The picture is clearer and finer.)

### Seamless Play

Select the play mode between Playlist chapter segments and partially deleted titles.

- [On] The chapters in Playlists (Video) are played seamlessly. This does not work when there are several audio types included on the Playlists (Video) and when using Quick View (PLAY × 1.3). Additionally, the positioning of chapter segments may change slightly.  
[Off] The points where chapters in Playlists (Video) change are played accurately, but the picture may freeze for a moment.

## Sound

(All factory default settings are indicated with underlined text.)

### Dynamic Range Compression

**DVD-V** (Dolby Digital only)

Change the dynamic range for late night viewing.

[On] [Off]

### Digital Audio Output

Change the settings when you have connected equipment through this unit's Digital Audio Output terminal (⇒ 9, 67).

● Press [OK] to show the following settings.

#### PCM Down Conversion

Select how to output audio with a sampling frequency of 96 kHz.

● Signals are converted to 48 kHz despite the settings below if the signals have a sampling frequency of over 96 kHz, or the disc has copy protection.

[On] Signals are converted to 48 kHz. (Choose when the connected equipment cannot process signals with a sampling frequency of 96 kHz.)

[Off] Signals are output as 96 kHz. (Choose when the connected equipment can process signals with a sampling frequency of 96 kHz.)

#### Dolby Digital\*

Select how to output the signal.

Select "Bitstream" if the connected equipment decodes the signal.

Select "PCM" if this unit decodes the signal and outputs it as 2 channels.

● Not making the proper settings may result in noise.

[Bitstream] When connected to equipment with a built-in Dolby Digital decoder.

[PCM] When connected to equipment without a built-in Dolby Digital decoder.

#### DTS\*

Select how to output the signal.

Select "Bitstream" if the connected equipment decodes the signal.

Select "PCM" if this unit decodes the signal and outputs it as 2 channels.

● Not making the proper settings may result in noise.

[Bitstream] When connected to equipment with a built-in DTS decoder.

[PCM] When connected to equipment without a built-in DTS decoder.

#### MPEG\*

Select how to output the signal.

Select "Bitstream" if the connected equipment decodes the signal.

Select "PCM" if this unit decodes the signal and outputs it as 2 channels.

● Not making the proper settings may result in noise.

[Bitstream] When connected to equipment with a built-in MPEG decoder.

[PCM] When connected to equipment without a built-in MPEG decoder.

\* Refer to the operating instructions for connected devices to verify whether or not they can decode each of the audio formats.

### Audio Mode for XP Recording

Choose the audio type when recording or copying with XP mode.

[Dolby Digital] (⇒ 78) [LPCM] (⇒ 78)

● The picture quality of LPCM recordings may be lower than that of normal XP mode recordings.

● The audio recording becomes Dolby Digital even if you selected LPCM when using a recording mode other than XP.

## Display

(All factory default settings are indicated with underlined text.)

### Language

Choose the language for these menus and on-screen messages.

[English] [Deutsch] [Français] [Italiano]

[Español]

### On-Screen Messages

Choose the approximate time until the digital channel information screen (⇒ 16) disappears automatically.

The length of time the control panel (⇒ 35) is displayed can also be changed, but "Off" does not work.

[Off] (The digital channel information is not displayed.)

[3 sec.] [5 sec.] [7 sec.] [10 sec.]

### Unit's Display

Changes the brightness of the unit's display.

This setting is fixed with "Automatic" if you set "Power Save in Standby" to "On" or "On Timer" (⇒ 65).

[Bright] [Dim]

[Automatic] The display turns dark during play and disappears when the unit is turned off. When "Power Save in Standby" is activated (⇒ 65), power consumption while in standby mode is reduced.

### Pause Live TV Icon

Select "Off" if you do not want to have the unit show the on-screen icon while using the Pause Live TV function.

[On] [Off]

### Screen Saver

[On] When this unit is not operated for approximately 5 minutes while the screen is being displayed, the screen saver is displayed. To return to the previous screen, press [OK].

[Off]

### FUNCTION MENU Display

[On] When the unit is turned on, the FUNCTION MENU will be displayed. (⇒ 7)

[Off]

## Connection

(All factory default settings are indicated with underlined text.)  
Depending on the connected equipment, some items may be shaded in grey on the display and cannot be selected, or you may not be able to change the settings.

### TV Aspect

Set to match the type of television connected.

[16:9] When connected to a 16:9 widescreen television.

[Pan & Scan] When connected to a 4:3 aspect television, side picture is trimmed for 16:9 picture.



[Letterbox] When connected to a 4:3 aspect television, 16:9 picture is shown in the letterbox style.



### TV System

Change the setting to match the equipment you are connecting with, or to match the title when there are both PAL and NTSC titles on the HDD.

[PAL] ● Select when connecting to a PAL or Multi-system television. Titles recorded using NTSC are played as PAL 60.  
● Select to record television programmes and PAL input from other equipment.  
● **[HDD]** Select when playing a PAL input title recorded on the HDD.

[NTSC] ● Select when connecting to a NTSC television. Television programmes cannot be recorded properly.  
● Select to record NTSC input from other equipment.  
● **[HDD]** Select when playing a NTSC input title recorded on the HDD.

#### Note

- This unit cannot record NTSC signals to discs that already have PAL signal recordings. (However, both types of programmes can be recorded onto the HDD.)
- During recording, timer recording standby or EXT LINK standby, this unit cannot play discs that do not match the "TV System" (PAL/NTSC) setting. Set "TV System" to match the discs before playing them.

### To change the setting all at once (PAL↔NTSC)

While stopped, keep pressing [■] and [▲ OPEN/CLOSE] on the main unit at the same time for 5 or more seconds.

## HDMI Settings

- Press [OK] to show the following settings.

### HDMI Video Format

You can only select items compatible with the connected equipment. This setting normally does not need to be changed. However if you are concerned about output picture quality, it may be improved by changing the setting.

- To enjoy High Quality Video up-converted to 1080p, you need to connect the unit directly to 1080p compatible HDTV. If this unit is connected to an HDTV through other equipment, it must also be 1080p compatible.

[576i / 480i] [576p / 480p] [720p] [1080i]

[1080p] When setting video output to "1080p", we recommend using High Speed HDMI Cables that have the HDMI logo (as shown on the cover) and are less than 5 meters to prevent video distortion etc.

[Automatic] Automatically selects the output resolution best suited to the connected television (1080p, 1080i, 720p, 576p / 480p or 576i / 480i).

### Aspect for 4:3 Video

To play a 4:3 title when connected with an HDMI cable, set how to show pictures on a 16:9 widescreen television.

[4:3] Picture output expands left or right.



[16:9] Picture is output as original aspect with side panels.



### Digital Audio Output

[HDMI and Optical]

[Optical Only] Select when this unit is connected to an amplifier with an optical digital audio cable and connected to a TV with an HDMI cable and you want to enjoy the highest quality of audio from discs (⇒ 67).

### VIERA Link

Set to use "HDAVI Control" function when connected with an HDMI cable to a device that supports "HDAVI Control".

[On]

[Off] Select when you do not want to use "HDAVI Control".

### AV1 Output

Set according to the terminal of the connected TV.  
If this unit is connected with an HDMI cable, you cannot select "RGB 1" or "RGB 2".

[Video]

Select when a TV that can receive a composite signal is connected.

[S Video]

Select when a TV that can receive an S Video signal is connected.

[RGB 1]

Select when a TV that can receive an RGB signal is connected. If you always would like to view the picture from the unit in RGB signal, select this mode. The TV screen will automatically switch to display the picture from the unit when the unit is turned on.

[RGB 2]

Select when a TV that can receive an RGB signal is connected. If you would like to switch to display the picture from the unit only when playback or viewing menus, select this mode.

## AV2 Settings

Set to match the connected equipment.  
 ● Press [OK] to show the following settings.

### AV2 Input

Set to "S Video" when receiving or recording S Video output from external equipment.

[Video] [S Video]

### Ext Link

This setting cannot be made when the "TV System" is set to "NTSC" (⇒ 63).

[Ext Link 1] When a digital satellite receiver which transmits a special control signal recordings via the 21-pin Scart cable is connected. Start and stop timings of recording are controlled by the control signal.

[Ext Link 2] When external equipment with a timer function is connected. When it turns on, recording starts. When it turns off, recording stops.

## Others

(All factory default settings are indicated with underlined text.)

### Remote Control

Change the remote control code on the main unit and the remote control (the two must match) if you place other Panasonic products close together.

[DVD 1] [DVD 2] [DVD 3]

Use "DVD 1", the factory set code, under normal circumstances.

- Press [▲, ▼] to select the code ("DVD 1", "DVD 2" or "DVD 3") and press [OK].

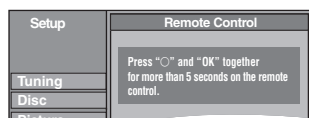

To change the code on the remote control

- While pressing [OK], press and hold the numbered button ([1], [2] or [3]) for more than 5 seconds.
- Press [OK].

■ When the following indicator appears on the unit's display



The unit's remote control code

Change the code on the remote control to match the main unit's (⇒ step ②).

#### Note

Executing "Shipping Condition" in the Setup menu returns the main unit code to "DVD 1". Change the remote control code to 1 (⇒ step ②).

## Clock

This unit usually obtains time and date information from digital broadcasts and automatically corrects the time several times a day. However, if the time is not set correctly, use the settings listed in the method below.

- Press [▲, ▼] to select "Off" of "Automatic" and press [OK].

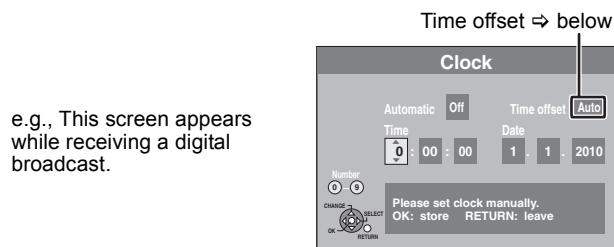

e.g., This screen appears while receiving a digital broadcast.

- Press [◀, ▶] to select the item you want to change.

The items change as follows:

Hour ↔ Minute ↔ Second ↔ Day ↔ Month ↔ Year

- Press [▲, ▼] to change the setting.

You can also use the numbered buttons for setting.

- Press [OK] when you have finished the settings.

The clock starts.

#### Note

If a TV station transmits a time setting signal, and when "Automatic" in the Clock setting menu is set to "On", the automatic time correction function checks the time and if necessary it is adjusted several times every day.

### ■ To change the time offset

When the time is not correct, set "Time offset" (from -2h to +2h).

- Press [▲, ▼] to select "On" of "Automatic" and press [OK] in step ①. Auto clock setting starts. This takes a few minutes. "Automatic clock setting completed." screen is displayed.
- Press [▶].
- Press [▲, ▼] to select the correct time offset and press [OK].
- Press [RETURN ↵].



## Standby Settings

- Press [OK] to show the following settings.

### Power Save in Standby

- [On] It will go into the Power Save in Standby mode when the unit is in standby mode.
- [Off] It is possible to start quickly from the standby mode. (Quick Start mode)
- [On Timer] "Power Save in Standby" is set to activate during the setting time period. (⇒ below)

- ① Press [▲, ▼] to select "On Timer" and press [OK].

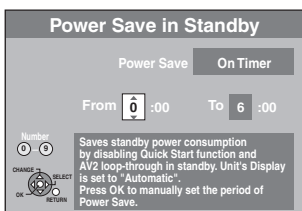

- ② Press [▲, ▼] to set the start time (hour).
  - ③ Press [◀, ▶] to select the stop time and press [▲, ▼] to set the stop time (hour).
  - ④ Press [OK] when you have finished the settings.
- You can also use the numbered buttons for setting.
  - You can set start and stop time by the hour.
  - If the clock has not been set, "Power Save in Standby" is activated at all hours.

### Auto Standby

Set the time to automatically turn the unit off. After the unit has finished operating, the unit will be turned off once the set time has passed.

- [30 minutes] [1 hour] [2 hours] [4 hours]  
[6 hours]  
[Off] The unit will not automatically turn off.

### Auto Standby after OTR

[On] This unit is turned to standby mode when this unit is not operated for approximately 5 minutes after completing One Touch Recording (⇒ 18).

[Off]

### Auto Standby after Copy

[On] This unit is turned to standby mode when this unit is not operated for approximately 5 minutes after completing copy (⇒ 45-53).

[Off]

### RF OUT ( Aerial Signal )

- [On] Broadcast signals are output from this unit. TV can receive broadcast signals even if this unit is in standby mode when connecting TV with this unit using the RF cable (⇒ 67).
- [Off] Press [◀, ▶] to select "Yes" when the confirmation message is displayed. Broadcast signals are not output from this unit to reduce standby power consumption.
- Power consumption is lowered additionally when "Power Save in Standby" is activated.
  - If this unit turns into standby mode when connecting TV with this unit using the RF cable, proper broadcast images do not appear on TV.

## DivX Registration

You need this registration code to purchase and play DivX Video-on-Demand (VOD) content (⇒ 29).

## System Update

In order to update this unit's software and to support system changes made by broadcasts, this unit periodically performs software updates.

Press [OK] to show the following settings.

- Update data is sent by an unscheduled digital broadcast. In order to receive these updates, you must be able to receive digital broadcasts.
- An update will take approximately 60 minutes. While the update is in progress, "SW-DL" appears on the unit's display. You cannot operate the unit until the update is complete. Removing the AC mains lead while the update is in progress may damage the unit.

### Software Update in Standby

[On] When you set this unit to standby mode, software updates are downloaded automatically.

[Off]

### Software Search Period

Selects the time to automatically perform updates when the unit is set to standby mode. This can only be set when "Software Update in Standby" is set to "On".

- If there is a programmed recording set for the time you have selected, the programmed recording will be given priority.

[Automatic]\*

[02:00-06:00] [06:00-10:00] [10:00-14:00]  
[14:00-18:00] [18:00-22:00] [22:00-02:00]

\* The unit will give priority to searching for update data at midnight.

### Software Update Search Now

Start the search for new software manually. A new software version is announced by a message. Do not turn your unit off during the update. This could result in the loss of data. A message shows that the update has finished.

- If applicable update data is found, press [◀, ▶] to select "Yes" and press [OK].

## Initialize

- Press [OK] to show the following settings.

### Shipping Condition\*1, \*2

All the settings except for the language settings, ratings level, ratings PIN, Slideshow Settings, and clock settings, etc. return to the factory preset.

[Yes] [No]

### Default Settings\*1, \*2

All the settings other than the tuning settings, clock settings, country settings, language settings, disc language settings, ratings level, ratings PIN, remote control code, etc. return to the factory presets.

[Yes] [No]

\*1 The timer recording programmes are also cancelled.

\*2 Recording on the HDD will not be deleted.

## Child Lock

The Child Lock deactivates all buttons on the unit and remote control. Use it to prevent other people from operating the unit.

**Press and hold [OK] and [RETURN ↵] simultaneously until “X HOLD” appears on the unit’s display.**



If you press a button while the Child Lock is on, “X HOLD” appears on the unit’s display and operation is impossible.

### To cancel the Child Lock

Press and hold [OK] and [RETURN ↵] simultaneously until “X HOLD” disappears.

## Television operation

You can configure the remote control TV operation buttons to turn the television on/off, change the television input mode, select the television channel and change the television volume.

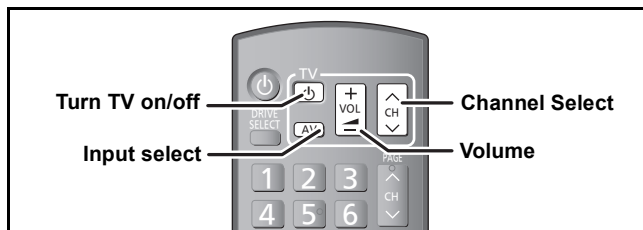

**1 Point the remote control at the television**  
**While pressing [TV], enter the code with the numbered buttons.**

e.g., 01: [0] ⇒ [1]    10: [1] ⇒ [0]

**2 Test by turning on the television and changing channels.**

- Repeat the procedure until you find the code that allows correct operation.
- If your television brand is not listed or if the code listed for your television does not allow control of your television, this remote control is not compatible with your television.

### Note

- If your television brand has more than one code listed, select the one that allows correct operation.

## Manufacturer and Code No.

Brand	Code	Brand	Code
Panasonic	01/02/03/04	METZ	05/28
AIWA	35	MITSUBISHI	05/19/20/47
AKAI	27/30	MIVAR	24
BEIJING	33	NEC	36
BEKO	05/71/72/73/74	NOBLEX	33
BENQ	58/59	NOKIA	25/26/27/60/61
BP	09	NORDMENDE	10
BRANDT	10/15	OLEVIA	45
BUSH	05	ONWA	30/39/70
CENTREX	66	ORION	05
CHANGHONG	69	PEONY	49/69
CURTIS	05	PHILCO	41/48/64
DAEWOO	64/65	PHILIPS	05/06/46
DESMET	05	PHONOLA	05
DUAL	05	PIONEER	37/38
ELEMIS	05	PROVIEW	52
FERGUSON	10/34	PYE	05
FINLUX	61	RADIOLA	05
FISHER	21	SABA	10
FUJITSU	53	SALORA	26
FUNAI	63/67	SAMSUNG	32/42/43/65/68
GOLDSTAR	05/50/51	SANSUI	05
GOODMANS	05	SANYO	21/54/55/56
GRADIENTE	36	SCHNEIDER	05/29/30
GRUNDIG	09	SEG	05/69/75/76/77/78
HIKONA	52	SELECO	05/25
HITACHI	05/22/23/40/41	SHARP	18
INNO HIT	05	SIEMENS	09
IRRADIO	30	SINUDYNE	05
ITT	25	SONY	08
JINGXING	49	TCL	31/33/66/67/69
JVC	17/30/39/70	TELEFUNKEN	10/11/12/13/14
KDS	52	TEVION	52
KOLIN	45	TEX ONDA	52
KONKA	62	THOMSON	10/15/44
LG	05/50/51	TOSHIBA	16/57
LOEWE	07/46	WHITE WESTINGHOUSE	05
MAG	52	YAMAHA	18/41

## Additional connections

### Connecting a television with AUDIO/VIDEO

- Connect to terminals of the same colour.

#### Television's rear panel

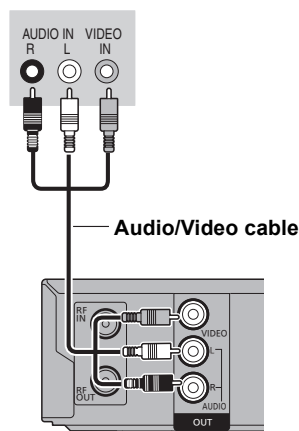

This unit's rear panel

## Connecting an amplifier with a digital input terminal

- To enjoy multi-channel surround sound DVD-Video, connect an amplifier with Dolby Digital, DTS and MPEG decoders.

### Required setting

"Digital Audio Output" in the Setup menu (⇒ 62)

- When this unit is connected to an amplifier with an optical digital audio cable and connected to a television with an HDMI cable, you can enjoy the highest quality of audio from the disc by setting "Digital Audio Output" to "Optical Only" in the Setup menu (⇒ 63). In this case audio is only output from the amplifier not the television.
- Before purchasing an optical digital audio cable (not included), check the terminal shape of the connected equipment.
- You cannot use DTS Digital Surround decoders not suited to DVD.

### Amplifier's rear panel

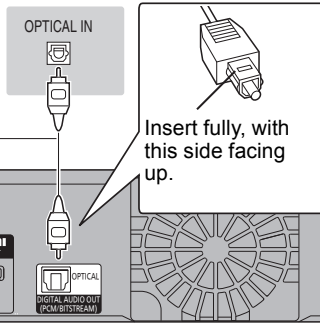

### Optical digital audio cable

Do not bend sharply when connecting.

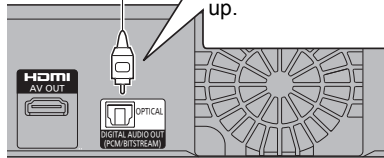

This unit's rear panel

## Connecting a stereo amplifier

- Connect to terminals of the same colour.

### Amplifier's rear panel

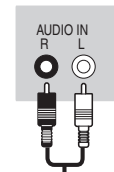

### Audio cable

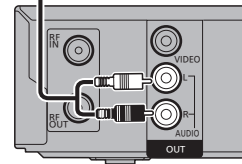

This unit's rear panel

## Connecting a television and VCR or digital satellite receiver

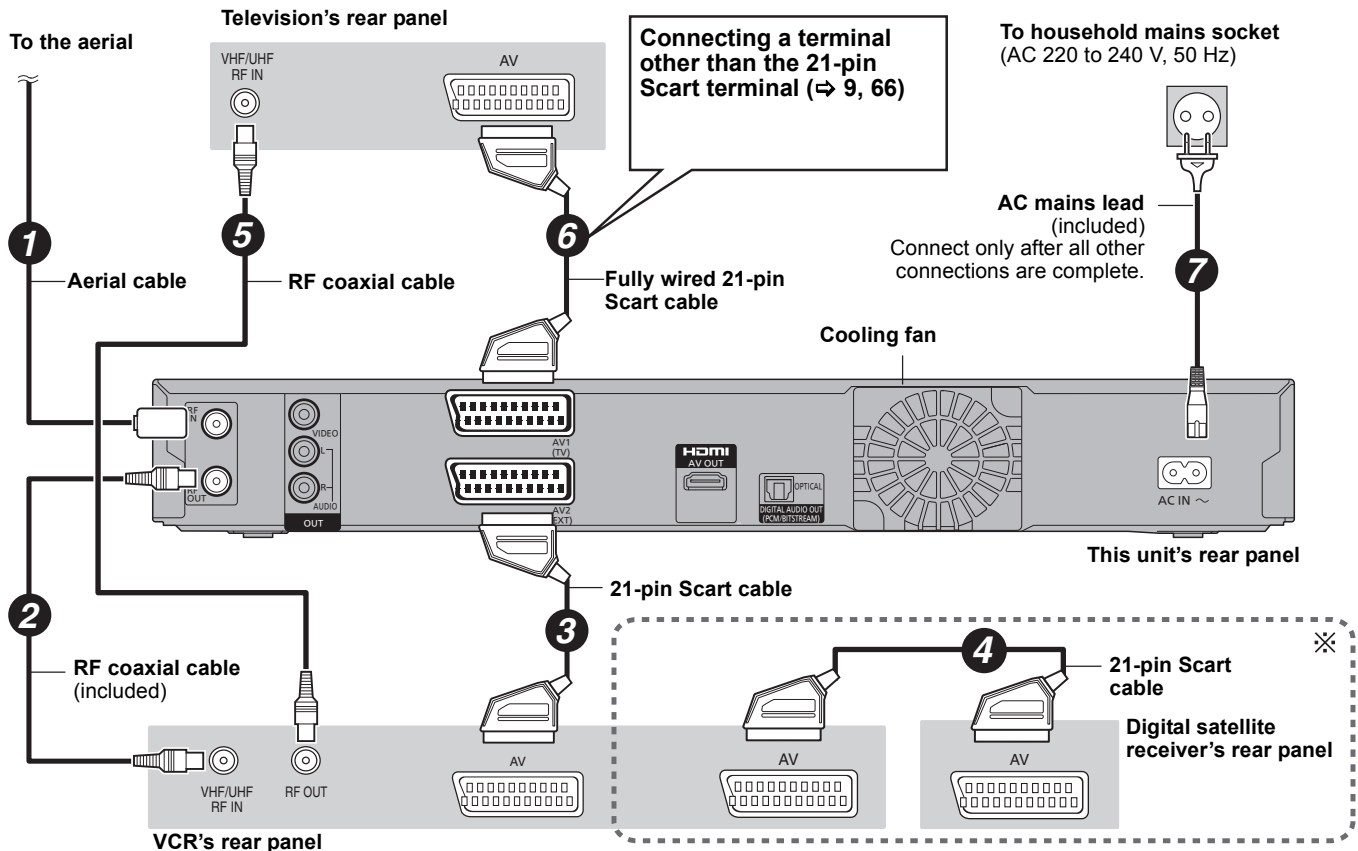

\* Only when connecting digital satellite receiver with this unit

### Required setting

"AV2 Input" setting in the Setup menu (⇒ 64)

Connect the unit directly to the television (⇒ 8, **B**)

# Frequently asked questions

Refer to the following items if you have any doubts about unit operations.

## Set up

### Which aerial is suitable for receiving digital terrestrial broadcasts?

- You can use your current aerial. Room rod aerials are also suitable. Use an indoor antenna if the reception is poor. Consult your local TV aerial installer.

### Can this unit receive or record High Definition (HD) broadcasts?

- No, this unit cannot receive or record High Definition (HD) broadcasts.

### What equipment is necessary to play multi channel surround sound?

- You cannot playback multi-channel sound on this unit without other equipment. You must connect this unit with an HDMI cable or an optical digital cable to an amplifier with a built-in (Dolby Digital, DTS or MPEG) decoder. (⇒ 9, 67)

### Are the headphones and speakers directly connected to the unit?

- You cannot directly connect them to the unit. Connect through the amplifier etc. (⇒ 67)

### Is my television progressive output compatible?

- All Panasonic televisions that have 576 (625)/50i · 50p, 480 (525)/60i · 60p input terminals are compatible. Consult the manufacturer if you have another brand of television.

## Disc

### Can I play DVD-Video and Video CDs bought in another country?

- You cannot play DVD-Video if their region number does not include "2" or "ALL". Refer to the disc's jacket for more information. (⇒ Cover)

### Can a DVD-Video that does not have a region number be played?

- The DVD-Video region number indicates the disc conforms to a standard. You cannot play discs that do not have a region number. You also cannot play discs that do not conform to a standard.

### Please tell me about disc compatibility with this unit.

- This unit records and plays DVD-RAM, DVD-R, DVD-RW (DVD-Video format), +R, and +RW, and plays DVD-RW (DVD Video Recording format). However you cannot directly record to a DVD-R DL or +R DL disc on this unit (playback and copy are possible). (⇒ 11–12)
- This unit also records and plays high speed recording compatible DVD-R, DVD-R DL, DVD-RW, +R, +R DL, +RW discs.

### Please tell me about CD-R and CD-RW compatibility with this unit.

- This unit plays CD-R/CD-RW discs which have been recorded in one of the following standards: CD-DA, Video CD, SVCD (conforming to IEC62107), DivX, MP3 and still pictures (JPEG). (⇒ 12, 14)
- You cannot write to a CD-R or CD-RW with this unit.

## Recording

### Can I record from a commercially purchased video cassette or DVD?

- Most commercially sold video cassettes and DVD are copy protected; therefore, recording is usually not possible.

### Can DVD-R, DVD-R DL, DVD-RW (DVD-Video format), +R, +R DL and +RW recorded on this unit be played on other equipment?

- You can play on compatible equipment such as DVD players after finalising the disc on this unit. However, depending on the condition of the recording, the quality of the disc and capabilities of the DVD player, play may not be possible.
- If you play a DVD-R DL, +R DL or +RW, use compatible equipment.

### Can a digital audio signal from this unit be recorded to other equipment?

- You can record if using the PCM signal. When recording DVD, change the "Digital Audio Output" settings to the following in the Setup menu. (⇒ 62)
  - PCM Down Conversion: On
  - Dolby Digital/DTS/MPEG: PCMHowever, only as long as digital recording from the disc is permitted and the recording equipment is compatible with a sampling frequency of 48 kHz.
- You cannot record MP3 signals.

### Can I high speed copy to a disc?

- Yes, you can. (When "Rec for High Speed Copy" was set to "On" before recording the programme.) Depending on the disc type, the maximum speed varies. (⇒ 45)

## USB

### What can or cannot be done using the USB port on this unit?

- You can play DivX (except for DivX VOD contents), MP3 or still picture (JPEG) files on a USB memory. (⇒ 28)
- You can copy still pictures (JPEG) files on a USB memory to the HDD or DVD-RAM. (⇒ 50, 51)
- You can copy MP3 files on a USB memory to the HDD. (⇒ 52)
- You can connect a video equipment and copy SD Video to the HDD or DVD-RAM. (⇒ 49)
- Data on the HDD or a disc cannot be transferred to a USB memory.
- Data on a USB memory cannot be edited or a USB memory cannot be formatted on this unit.
- Some USB memories cannot be used with this unit. (⇒ 13)

## Music

### Can I transfer the music tracks from HDD to the disc or USB memory?

- No, you cannot.

## TV Channels

### Please tell me about TV reception channels.

- Channel coverage depends on the tuner system you use. Refer to the following list of TV Reception Channels.

#### List of TV Reception Channels

Tuner System	Channel Coverage	VHF	UHF	CATV
DVB-T	France Italy Spain	5 – 10 D – H2 5 – 12	21 – 69 21 – 69 21 – 69	—

## On the television

<b>This unit is not authorised to play this protected DivX video.</b>	<ul style="list-style-type: none"> <li>You are trying to play the DivX VOD content that was purchased with a different registration code. You cannot play the content on this unit. (DivX) (⇒ 29)</li> </ul>
<b>Cannot finish recording completely. Copy-protect signal was detected.</b>	<ul style="list-style-type: none"> <li>The programme was copy-protected.</li> </ul>
<b>Disc is full, or maximum number of titles are recorded. Cannot finish recording completely.</b>	<ul style="list-style-type: none"> <li>The HDD or disc may be full.</li> <li>The maximum number of programme has been exceeded. (⇒ 21)</li> <li><b>HDD RAM -RW(V) +RW</b> Create space by deleting any unnecessary titles. [Even if you delete recorded content from the DVD-R, DVD-R DL, +R or +R DL there is no increase in disc space. Available space on DVD-RW (DVD-Video format) and +RW increases only when the last recorded title is deleted.] (⇒ 19, 37, 57)</li> <li>Use a new disc.</li> </ul>
<b>Cannot record. Maximum number of titles exceeded.</b>	
<b>Cannot playback. TV system is different from the setting. To playback, please change the TV System in Setup.</b>	<ul style="list-style-type: none"> <li>You tried to play a title recorded using a different encoding system from that of the TV system currently selected on the unit. Alter the "TV System" setting on this unit to suit. (⇒ 63)</li> </ul>
<b>Cannot play on this unit.</b>	<ul style="list-style-type: none"> <li>You tried to play a non-compatible image. (⇒ 14)</li> </ul>
<b>No Disc</b>	<ul style="list-style-type: none"> <li>The disc may be upside down.</li> </ul>
<b>No folders.</b>	<ul style="list-style-type: none"> <li>There is no compatible folder in this unit. (⇒ 14)</li> </ul>
<b>Not enough space in the copy destination.</b>	<ul style="list-style-type: none"> <li>Create space by deleting any unnecessary items. (⇒ 19, 37, 41, 57)</li> <li>Delete one or more items registered on the copy list to ensure that the "Destination Capacity:" is not exceeded. (⇒ 48, 51, 53)</li> </ul>
<b>This is a non-recordable disc.</b>	<ul style="list-style-type: none"> <li>The disc may be dirty or scratched. (⇒ 15)</li> <li>The unit cannot record on the disc you inserted. Insert a DVD-RAM or unfinalised DVD-R, DVD-RW (DVD-Video format), +R or +RW. (⇒ 11)</li> <li>You inserted an unformatted DVD-RAM, DVD-RW, +R, +R DL or +RW. (⇒ 57)</li> <li>You cannot directly record to a DVD-R DL and +R DL disc on this unit. Record to the HDD and then copy to the disc.</li> </ul>
<b>Unable to format.</b>	
<b>This disc is not formatted properly. Format it using DVD Management in FUNCTION MENU.</b>	
<b>Not enough space on HDD. Space of 4 hours ( in SP mode ) is necessary. Maximum number of titles is recorded on HDD. Please delete unwanted titles.</b>	<ul style="list-style-type: none"> <li><b>-R DL +R DL</b> It is not possible to copy when there is not enough free space on the HDD or when the total number of the recorded titles on the HDD and the titles to be copied are greater than 499. Delete unwanted titles from the HDD. (⇒ 19, 37, 57)</li> </ul>
<b>Rental Expired.</b>	<ul style="list-style-type: none"> <li>The DivX VOD content has zero remaining plays. You cannot play it. (DivX) (⇒ 29)</li> </ul>
⊘	<ul style="list-style-type: none"> <li>The operation is prohibited by the unit or disc.</li> </ul>

## Language code list Enter the code with the numbered buttons.

Abkhazian: 6566	Catalan: 6765	Gujarati: 7185	Lingala: 7678	Rhaeto-Romance: 8277	Tamil: 8465
Afar: 6565	Chinese: 9072	Hausa: 7265	Lithuanian: 7684	Tatar: 8484	
Afrikaans: 6570	Corsican: 6779	Hebrew: 7387	Macedonian: 7775	Romanian: 8279	Telugu: 8469
Albanian: 8381	Croatian: 7282	Hindi: 7273	Malagasy: 7771	Russian: 8285	Thai: 8472
Amharic: 6577	Czech: 6783	Hungarian: 7285	Malay: 7783	Samoan: 8377	Tibetan: 6679
Arabic: 6582	Danish: 6865	Icelandic: 7383	Malayalam: 7776	Sanskrit: 8365	Tigrinya: 8473
Armenian: 7289	Dutch: 7876	Indonesian: 7378	Maltese: 7784	Scots Gaelic: 7168	Tonga: 8479
Assamese: 6583	English: 6978	Interlingua: 7365	Maori: 7773	Serbian: 8382	Turkish: 8482
Aymara: 6589	Esperanto: 6979	Irish: 7165	Marathi: 7782	Serbo-Croatian: 8372	Turkmen: 8475
Azerbaijani: 6590	Estonian: 6984	Italian: 7384	Moldavian: 7779	Shona: 8378	Twi: 8487
Bashkir: 6665	Faroese: 7079	Japanese: 7465	Mongolian: 7778	Sindhi: 8368	Ukrainian: 8575
Basque: 6985	Fiji: 7074	Javanese: 7487	Nauru: 7865	Singhalese: 8373	Urdu: 8582
Bengali; Bangla: 6678	Finnish: 7073	Kannada: 7578	Nepali: 7869	Slovak: 8375	Uzbek: 8590
Bhutani: 6890	French: 7082	Kashmiri: 7583	Norwegian: 7879	Slovenian: 8376	Vietnamese: 8673
Bihari: 6672	Frisian: 7089	Kazakh: 7575	Oriya: 7982	Somali: 8379	Volapük: 8679
Breton: 6682	Galician: 7176	Kirghiz: 7589	Pashto, Pushto: 8083	Spanish: 6983	Welsh: 6789
Bulgarian: 6671	Georgian: 7565	Korean: 7579	Persian: 7065	Sundanese: 8385	Wolof: 8779
Burmese: 7789	German: 6869	Kurdish: 7585	Polish: 8076	Swahili: 8387	Xhosa: 8872
Byelorussian: 6669	Greek: 6976	Laotian: 7679	Portuguese: 8084	Swedish: 8386	Yiddish: 7473
Cambodian: 7577	Greenlandic: 7576	Latin: 7665	Punjabi: 8065	Tagalog: 8476	Yoruba: 8979
	Guarani: 7178	Latvian, Lettish: 7686	Quechua: 8185	Tajik: 8471	Zulu: 9085

## On the unit's display

The following messages or service numbers appear on the unit's display when something unusual is detected during startup and use.

<b>DVD</b> □ ("□" stands for a number.)	<ul style="list-style-type: none"> <li>The remote control and main unit are using different codes. Change the code on the remote control.</li> </ul>  <p>Press and hold [OK] and the indicated number button at the same time for more than 5 seconds. (⇒ 64)</p>
<b>HARD ERR*</b>	<ul style="list-style-type: none"> <li>If there is no change after turning the unit on and off, consult the dealer where the unit was purchased.</li> </ul>
<b>NoERAS</b>	<ul style="list-style-type: none"> <li>You cannot delete items on this disc. The disc may be damaged. Use a new disc.</li> </ul>
<b>NoREAD</b>	<ul style="list-style-type: none"> <li>The disc is dirty or badly scratched. The unit cannot record, play, or edit. (⇒ 15)</li> <li>This message may appear when the DVD lens cleaner has finished cleaning. Press [▲ OPEN/CLOSE] on the main unit to eject the disc. (⇒ 5)</li> </ul>
<b>NoWRIT</b>	<ul style="list-style-type: none"> <li>You cannot write to this disc. The disc may be damaged. Use a new disc.</li> </ul>
<b>PLEASE WAIT*</b>	<ul style="list-style-type: none"> <li>There was a power failure or the AC plug was disconnected while the unit was on. The unit is carrying out its recovery process. This process restores the unit to normal operation. The unit is not broken. Wait until the message disappears.</li> </ul>
<b>PROG FULL*</b>	<ul style="list-style-type: none"> <li>There are already 32 timer programmes. Delete unnecessary timer programmes. (⇒ 25)</li> </ul>
<b>REMOVE</b>	<ul style="list-style-type: none"> <li>The USB device is drawing too much power. Remove the USB device and turn the unit off.</li> </ul>
<b>SP 35:50</b> <b>LP 151h</b> "SP", "LP" and the numbers are examples.	<ul style="list-style-type: none"> <li>Available space on the HDD or disc. The example "SP 35:50" is displayed when less than 100 hours are available and the example "LP 151h" is displayed when over 100 hours are available. "SP" and "LP" are recording modes, "35:50" means "35 hours 50 minutes" and "151h" means "151 hours".</li> </ul>
<b>SW-DL</b>	<ul style="list-style-type: none"> <li>The unit is performing a software update. (⇒ 65)</li> </ul>
<b>UNFORMAT*</b>	<ul style="list-style-type: none"> <li>You inserted an unformatted DVD-RAM, DVD-RW, +RW, an unused +R, +R DL or DVD-RW (DVD-Video format) that has been recorded on other equipment. Format the disc to use it. However all the recorded contents on the disc are deleted. (⇒ 57)</li> </ul>
<b>UNSUPPORT*</b>	<ul style="list-style-type: none"> <li>You have inserted a disc the unit cannot play or record on. (⇒ 11–12)</li> <li>You tried to operate with a non-compatible USB memory. (⇒ 13)</li> </ul>
<b>F74</b>	<ul style="list-style-type: none"> <li>The HDMI connection could not be authenticated due to a transfer malfunction. Consult the dealer where the unit was purchased.</li> </ul>
<b>F75</b>	<ul style="list-style-type: none"> <li>The HDMI connection could not be authenticated due to an internal data malfunction. Consult the dealer where the unit was purchased.</li> </ul>
<b>U59</b>	<ul style="list-style-type: none"> <li>The unit is hot. The unit switches to standby for safety reasons. Wait for about 30 minutes until the message disappears. Select a position with good ventilation when installing the unit. Do not block the cooling fan on the rear of the unit.</li> </ul>
<b>U61</b>	<ul style="list-style-type: none"> <li>(When a disc is not inserted) Displays when a malfunction has occurred. This is displayed when the unit is in the recovery process to return to normal operation. Once the display clears you can use the unit again. If it remains displayed, consult the dealer where the unit was purchased.</li> </ul>
<b>U76</b>	<ul style="list-style-type: none"> <li>HDMI cannot be output because this unit is connected to a model that does not support copyright protection.</li> </ul>
<b>U80</b> <b>U81</b> <b>U99</b>	<ul style="list-style-type: none"> <li>The unit fails to operate properly. Press [⏻/⏪] on the main unit to switch the unit to standby mode. Now press [⏻/⏪] on the main unit again to turn the unit on.</li> </ul>
<b>U88</b>	<ul style="list-style-type: none"> <li>(When a disc is inserted) Displays when there was something unusual detected with the disc while recording, playback or copy. This is displayed when the unit is in the recovery process to return to normal operation. Once the display clears you can use the unit again. (⇒ 71) If it remains displayed, consult the dealer where the unit was purchased.</li> </ul>
<b>H□□ or F□□</b>	<ul style="list-style-type: none"> <li>There is something unusual. (The service number displayed after H and F depends on the unit's condition.)</li> <li>Check the unit using the troubleshooting guide. If the service number does not disappear, do the following. (⇒ 71–76) <ol style="list-style-type: none"> <li>Disconnect the plug from the household mains socket, wait a few seconds, then reconnect it.</li> <li>Press [⏻/⏪] to turn the power on. (The unit may be fixed.)</li> </ol>                     If the service number does not disappear despite after doing the above, request service from the dealer. Inform the dealer of the service number when requesting service.                 </li> </ul>
<b>X HOLD</b>	<ul style="list-style-type: none"> <li>The Child Lock function is activated. Press and hold [OK] and [RETURN ↵] at the same time until "X HOLD" disappears. (⇒ 66)</li> </ul>

\* The message are alternately displayed.

# Troubleshooting guide

Before requesting service, make the following checks. If you are in doubt about some of the check points, or if the solutions indicated in the chart do not solve the problem, consult your dealer for instructions.

## The following do not indicate a problem with this unit:

- Regular disc rotating sounds.
- Poor reception due to atmospheric conditions.
- Image disturbance during search.
- Interruptions in reception due to periodic satellite broadcasting breaks.
- Operations are slow to respond when "Power Save in Standby" is activated.
- Operations do not work due to a poor-quality disc. (Try again using a Panasonic disc.)
- The unit freezes due to one of its safety devices being activated. (Press and hold [⏻/|] on the main unit for 3 seconds.)
- When the unit is turned on or off, there may be an unexpected sound.

## Power

### No power.

#### The unit does not turn on pressing [⏻].

- Insert the AC mains lead securely into a known active household mains socket. (⇒ 8, 67)
- Linked timer recordings with external equipment is in recording standby ("EXT-L" on the unit's display blinks when [⏻] is pressed). Press [EXT LINK] to cancel the recording standby. (⇒ 23)

### The unit switches to standby mode.

- One of the unit's safety devices is activated. Press [⏻/|] on the main unit to turn the unit on.

### The power is turned off automatically.

- If you connected this unit to a "HDAVI Control" compatible TV with an HDMI cable, or connected this unit to a Q Link-compatible TV with a fully wired 21-pin Scart cable, this unit will be automatically set to standby mode when the TV is set to standby mode. (⇒ 34)

### This unit turns off when the TV input is switched.

- This is a normal phenomenon when using VIERA Link (HDAVI Control 4 or later). For details please read the operating instructions for the TV.

## Displays

### The display is dim.

- Change "Unit's Display" in the Setup menu. (⇒ 62)

### "0:00" is flashing on the unit's display.

- Set the clock. (⇒ 64)

### The time recorded on the disc and the available time shown do not add up. The displayed time of this unit is different from the actual recording time or MP3 recording time.

- Times shown may disagree with actual times.
- Available recording space on DVD-RW (DVD-Video format) or +RW increases only when the last recorded title is deleted. It does not increase if other titles are deleted.
- Even if you delete recorded content from the DVD-R, DVD-R DL, +R or +R DL, there is no increase in disc space.
- More disc space than the actual recording time is used after recording or editing the DVD-R, DVD-R DL, +R or +R DL 200 times or more.
- While searching, the elapsed time may not display correctly.

### The clock is not correct.

- Under adverse reception conditions, etc., the automatic time correction function may not work. In this case, "Automatic" is automatically turned to "Off". If re-setting the Auto Clock Setting does not work, set the time manually. (⇒ 64)

### Compared to the actual recorded time, the elapsed time displayed is less. (Only when recording in NTSC)

- The displayed recording/play time is converted from the number of frames at 29.97 frames (equal to 0.999 seconds) to 1 second. There will be a slight difference between the time displayed and the actual elapsed time (e.g., actual 1 hour elapsed time may display as approximately 59 minutes 56 seconds). This does not affect the recording.

### "U88" is displayed and the disc cannot be ejected.

- The unit is carrying out the recovery process. Do the following to eject the disc.
  - 1 Press [⏻/|] on the main unit to switch the unit to standby. If the unit doesn't switch to standby, press and hold [⏻/|] on the main unit for about 3 seconds. The unit is forcibly switched to standby.
  - 2 While the unit is off, press and hold [■] and [CH ^] on the main unit at the same time for about 5 seconds. Remove the disc.

## TV screen and video

### Television reception worsens or becomes impossible after connecting the unit.

- This can occur because the signals are being divided between the unit and other equipment. It can be solved by using a signal booster, available from audio-visual suppliers. If it is not solved by using a signal booster, consult the dealer.
- Broadcast signals may not be output from this unit's RF OUT terminal. Select "On" in "RF OUT ( Aerial Signal )" in the Setup menu. (⇒ 65)

### The digital channel information or control panel does not appear.

#### Status messages do not appear.

- Select the length of time (3–10 sec.) in the "On-Screen Messages" in the Setup menu. (⇒ 62)
- The digital channel information will not appear during playback or recording.
- The control panel is only displayed when connected to a TV supporting "HDAVI Control 2" or later. (⇒ 35)

### Some functions of DVB-T do not work.

- The unit does not necessarily support all DVB-T functions such as MHP (Multimedia Home Platform) etc. New functions introduced by broadcasters cannot be guaranteed to work.

### Screen size is wrong.

- Check the settings for "TV Aspect" in the Setup menu. (⇒ 63)
- If you connect an HDMI cable, set "Aspect for 4:3 Video" to "16:9" in the Setup menu. (⇒ 63)

### The recorded title's screen size is wrong.

- Set "Rec for High Speed Copy" to "On", and set the "Aspect for Recording" to "4:3". (⇒ 61)
- 16:9 aspect programmes are recorded in 4:3 aspect in the following cases.
  - [R] [R DL] [RW(V)] If you recorded or copied using "EP" or "FR (recordings 5 hours or longer)" recording mode.
  - If you recorded or copied to a +R, +R DL or +RW.
  - If you recorded with the "Aspect for Recording" set to "4:3" in the Setup menu.  
When you want to record 16:9 programme in the same aspect, set "Rec for High Speed Copy" to "On", and set the "Aspect for Recording" to "16:9". (⇒ 61)
- By setting "Aspect for Recording" to "Automatic", there is a chance that the recording will be made using the wrong aspect. Match the aspect settings to the broadcast when recording. (⇒ 61)  
It may be possible to adjust the display mode on the TV. Refer to your television's operating instructions.

### Picture does not appear during timer recording.

- Timer recordings work regardless whether the unit is on or off. To confirm the timer recording is going to work properly, turn the unit on.

### The screen changes automatically.

- When "Screen Saver" in the Setup menu is set to "On", the display may turn to the screen saver mode automatically if there is no operation for 5 minutes or more. (⇒ 62) Press [OK] to return to the previous screen.

### There is a lot of after-image when playing video.

- Set "Playback NR" in the Picture menu to "Off". (⇒ 54)

### There is no apparent change in picture quality when adjusted with the Picture menu in the on-screen menus.

- The effect is less perceivable with some types of video.

### The images from this unit do not appear on the television.

#### Picture is distorted.

- Make sure that the television is connected to the AV1 terminal, VIDEO OUT terminal or HDMI terminal on this unit. (⇒ 8, 9, 66, 67)
- Make sure that the television's input setting (e.g., AV 1) is correct.
- The unit's "TV System" setting differs from the TV system used by the disc now playing. While stopped, keep pressing [■] and [▲ OPEN/CLOSE] on the main unit for 5 or more seconds. The system switches from PAL to NTSC or vice versa. (⇒ 63)
- When this unit is connected with an HDMI cable, use a disc that matches with this unit's TV system.
- Picture may not be seen when more than 4 devices are connected with HDMI cables. Reduce the number of connected devices.

### The picture is distorted during play, or video will not play correctly.

- You may be playing a TV programme recorded with poor reception or unfavourable weather conditions.
- The picture may be distorted or a black screen may appear briefly between recorded titles in the following situations:
  - between titles recorded with different recording modes.
  - between scenes recorded with different aspect ratios.
  - between scenes recorded with different resolutions.
  - between playlist chapters.

## Sound

### No sound.

### Low volume.

### Distorted sound.

### Cannot hear the desired audio type.

- Check the connections and the "Digital Audio Output" settings. Check the input mode on the amplifier if you have connected one. (⇒ 8, 9, 62, 63, 66, 67)
- Press [AUDIO] to select the audio. (⇒ 26)
- Audio may not be output due to how files were created. (DivX)
- Audio may not be heard when more than 4 devices are connected with HDMI cables. Reduce the number of connected devices.
- The sound effects will not work when the bitstream signal is output from the HDMI AV OUT terminal or the OPTICAL DIGITAL AUDIO OUT terminal.
- To output audio from a device connected with an HDMI cable, set "Digital Audio Output" to "HDMI and Optical" in the Setup menu. (⇒ 63)
- Depending on the connected equipment, the sound may be distorted if this unit is connected with an HDMI cable.

### Cannot switch audio.

- You cannot switch the audio in the following cases.
  - When a DVD-R, DVD-R DL, DVD-RW (DVD-Video format), +R, +R DL or +RW disc is in the disc tray while DVD drive is selected.
  - When the recording mode is XP and "Audio Mode for XP Recording" is set to "LPCM". (⇒ 62)
  - When "Rec for High Speed Copy" is set to "On". (The default setting is "On"). (⇒ 61)
- The amplifier is connected using an optical digital cable or an HDMI cable. You cannot switch the audio if "Dolby Digital" is set to "Bitstream". Set "Dolby Digital" to "PCM" or connect using audio cables. (⇒ 9, 62, 67)
- There are discs for which audio cannot be changed because of how the disc was created.

## Operation

### Cannot operate the television.

#### The remote control doesn't work.

- Change the manufacturer code. Some televisions cannot be operated even if you change the code. (⇒ 66)
- The remote control and main unit are using different codes. Change the code on the remote control. (⇒ 64)

Press and hold [OK] and the indicated number button at the same time for more than 5 seconds.



- The batteries are depleted. Replace them with new ones. (⇒ 4)
- You are not pointing the remote control at the main unit's remote control signal sensor during operation. (⇒ 4)
- Coloured glass may obstruct the signal reception/transmission.
- Don't place the signal sensor in direct sunlight or in areas that may be subject to sunlight exposure.
- It may be necessary to set the code on the remote control again after changing the batteries. (⇒ 64)
- It may be necessary to set the manufacturer code again after changing the batteries. (⇒ 66)
- The child lock function is activated. (⇒ 66)

### The unit is on but cannot be operated.

- Recording drive or playback drive has not been selected properly. (⇒ 17, 18)
- Some operations may be prohibited by the disc.
- The unit is hot ("U59" appears on the display). Wait for "U59" to disappear.
- One of the unit's safety devices may have been activated. Reset the unit as follows:
  - 1 Press [⏻/⏪] on the main unit to switch the unit to standby. If the unit doesn't switch to standby, press and hold [⏻/⏪] on the main unit for about 3 seconds. The unit is forcibly switched to standby. Alternatively, disconnect the AC mains lead, wait one minute, then reconnect it.
  - 2 Press [⏻/⏪] on the main unit to switch it on. If the unit still cannot be operated, consult the dealer.

### Cannot eject disc.

- The unit is recording.
- Linked timer recordings with external equipment is in recording standby ("EXT-L" on the unit's display blinks when [⏻] is pressed). Press [EXT LINK] to cancel the recording standby. (⇒ 23)
- The unit may have a problem. While the unit is off, press and hold [■] and [CH ^] on the main unit at the same time for about 5 seconds. Remove the disc and consult the dealer. If the Child Lock function is activated, above operation does not work. Cancel the Child Lock function. (⇒ 66)



## Cannot tune channels. Cannot download channel presets from the television.

- Check the connections. (⇒ 8, 67)
- You must connect to a Q Link compatible TV with a fully wired 21-pin Scart cable or a VIERA Link (HDAVI Control 3 or later) compatible TV with an HDMI cable.

## Startup is slow.

- Deactivate "Power Save in Standby" in the Setup menu. (⇒ 65)
- Startup takes time in the following situations:
  - A disc other than a DVD-RAM is inserted.
  - The clock is not set.
  - Immediately after a power failure or the AC mains lead is connected.
  - When the unit is connected with an HDMI cable.

## Recording, timer recording and copying

### Cannot record. Cannot copy.

- You haven't inserted a disc or the disc you inserted cannot be recorded on. Insert a disc the unit can record onto. (⇒ 11)
- The disc is unformatted. Format the disc. **RAM -RW(V) +R +R DL +RW** (⇒ 57)
- The disc is protected with DVD Management. (⇒ 56)
- Some programmes have limitations on the number of times they can be recorded (CPRM). (⇒ 78)
- You cannot record when there is not enough space or when the number of titles has reached its limit. Delete unwanted titles or use a new disc. (⇒ 19, 37, 57)
- Video cannot be recorded onto a DVD-R with still images recorded on it.
- You cannot directly record to a DVD-R DL or +R DL disc on this unit.  
Record to the HDD and then copy to the disc.
- **-R DL +R DL**. In the following situations, you cannot copy. Delete unnecessary titles from the HDD and then copy. (⇒ 19, 37, 57)
  - If there is not enough space available on the HDD (If you will copy titles from the HDD to a blank disc and fill the entire disc, HDD disc space equivalent to 4 hours of SP mode recording is necessary).
  - If the number of recorded titles and the number of titles to be copied has exceeded 499.
- You cannot record and copy on finalised discs. However, you can record and copy again if you format DVD-RW.
- Due to peculiarities of DVD-R, DVD-R DL, DVD-RW (DVD-Video format), +R, +R DL and +RW you may be unable to record onto them if you either insert and remove the disc or switch the unit on and off while a disc is loaded, a total of fifty times.
- DVD-R, DVD-R DL, DVD-RW (DVD-Video format), +R, +R DL and +RW recorded on this unit may not be recordable on other Panasonic DVD Recorders.
- This unit cannot record NTSC signals to discs that already have PAL signal recordings. (However, both types of programmes can be recorded onto the HDD.) Play of discs recorded with both PAL and NTSC on another unit is not guaranteed.
- Some broadcasts are copyright protected.

### Cannot record from external equipment.

- Check that the connection is correct. (⇒ 49, 67)
- Select the AV2 input.

### Timer recording does not work properly.

- The timer programme is incorrect or different timer programme times overlap. Correct the programme. (⇒ 25)
- The programme is not in timer recording standby. (The timer icon "⊙" in the timer recording list is not on.) (⇒ 25)
- Set the clock. (⇒ 64)

### Timer recording does not stop even when [■] is pressed.

- When using the linked timer recording with external equipment, press [EXT LINK]. ("EXT-L" disappears.) (⇒ 23)
- If you start recording immediately after turning on the unit while "Power Save in Standby" is not activated (Quick Start mode), you cannot then stop recording for a few seconds.

### The timer programme remains even after recording finishes.

- The timer programme remains if set to daily or weekly.

### A part or whole of a recorded title has been lost.

- If there is a power failure or the plug is disconnected from the household mains socket while recording or editing, the title may be lost or the HDD/disc may become unusable. You will have to format the disc (**HDD RAM -RW(V) +RW**) or use a new disc. We cannot offer any guarantee regarding lost programmes or discs. (⇒ 57)

### Cannot copy to a DVD-R, etc. disc using the high speed mode.

- When recording to the HDD, set "Rec for High Speed Copy" to "On" in the Setup menu. (The default setting is "On"). (⇒ 61)
- In the following cases, high speed mode does not work, even if the titles were recorded with "Rec for High Speed Copy" set to "On".
  - **+R +R DL +RW** If recorded in "EP" or "FR (recordings 5 hours or longer)" mode.
  - **+R +R DL +RW** If recorded in 16:9 aspect.
  - **-R -R DL -RW(V)** If recorded in 16:9 aspect using "EP" mode or "FR" (recordings 5 hours or longer) mode.
- **+R +R DL +RW** Titles recorded on other Panasonic DVD recorders with "Rec for High Speed Copy" set to "On", and then copied to the HDD on this unit may not copy to +R, +R DL or +RW discs with high-speed copy.

### When copying, it takes a long time even when high speed mode is selected.

- Use a disc that is compatible with high speed recording. Even if the disc is high speed recording compatible, the maximum speed may not be possible due to the condition of the disc.
- It takes longer than normal to copy many titles.
- You cannot high speed copy to DVD-R titles longer than 6 hours when using other Panasonic DVD Recorders that are not compatible with EP ( 8 hours ) mode recording.

### An unusually loud sound is coming from the rotating DVD-R, etc.

- When recording or high speed copying to a DVD-R, DVD-R DL, DVD-RW (DVD-Video format), +R, +R DL and +RW the sound of the disc rotating may be louder than normal, however, this is not a problem.

## Play

### Play fails to start even when [▶] (PLAY) is pressed.

#### Play starts but then stops immediately.

- Insert the disc correctly with the label facing up. (⇒ 15)
- The disc is dirty. (⇒ 15)
- You tried to play a blank disc or disc unplayable on this unit. (⇒ 11–12)
- You tried to play a +RW that needs to be finalised on the equipment used for recording.
- You may be able to copy a “One time only recording” title that was recorded to DVD-RAM using a different Panasonic DVD Recorder to this unit’s HDD, but play is not possible due to copyright protection.
- When recording to DVD-RAM using “EP ( 8 hours )” mode, play may not be possible on DVD players that are compatible with DVD-RAM. In this case use “EP ( 6 hours )” mode. (⇒ 61)
- If playing DivX VOD content, refer to the homepage where you purchased it. (DivX) (⇒ 29)
- Make sure that the TV is turned on. If the menu or messages are displayed, follow the on-screen instructions.

### Audio and video momentarily pause.

- This occurs between playlist chapters.
- This occurs between chapters and with partially deleted titles on finalised DVD-R, DVD-R DL, DVD-RW (DVD-Video format), +R, +R DL and +RW that have been copied using the high speed mode.
- This occurs as scenes change during Quick View.
- **-R DL +R DL** When playing a title recorded on both layers, the unit automatically switches between layers and plays the title in the same way as a normal programme. However, video and audio may momentarily cut out when the unit is switching layers. (⇒ 11)

### DVD-Video is not played.

- You have set a ratings level to limit DVD-Video play. Change this setting. (⇒ 61)
- Ensure disc is for the correct DVD-Video region number, and is not defective. (⇒ Cover)

### Alternative soundtrack and subtitles cannot be selected.

- The languages are not recorded on the disc.
- You may not be able to use the on-screen menus to change the soundtrack and subtitles on some discs. Use the disc’s menus to make changes. (⇒ 17)

### No subtitles.

- Subtitles are not recorded on the disc.
- Turn the subtitles on and select “Text” or the subtitle number. (⇒ 54)

### Angle cannot be changed.

- Angles can only be changed during scenes where different angles are recorded.

### You have forgotten your ratings PIN. You want to cancel the ratings level.

- The ratings level returns to the factory preset. While the disc tray is open, press [DRIVE SELECT] to select the DVD drive, then press and hold [● REC] and [▶] on the main unit at the same time for 5 or more seconds (“INIT” will appear on the unit’s display).

### Quick View does not work.

- This does not work when audio is other than Dolby Digital.
- This does not work when recording is in XP or FR mode.

### The resume play function does not work.

- Memorized positions are cancelled when
  - press [■] several times.
  - open the disc tray.
  - **CD VCD USB** turn off the unit.
  - if a recording or timer recording was executed.

### The Video CD picture does not display properly.

- When connecting to Multi-system TV, select “NTSC” in “TV System” in the Setup menu. (⇒ 63)
- When connecting to PAL TV, the lower part of the picture cannot be displayed correctly during search.

### Time Slip, Manual Skip, etc. does not work.

- These functions do not work with finalised discs.
- Time Slip does not work when the unit’s “TV System” settings are different from the title recorded on the disc. (⇒ 63)

### It takes time before play starts.

- This is normal on DivX video. (DivX)

### Picture stops.

- Picture may stop if the DivX files are greater than 4 GB. (DivX)

### Cannot see the beginning of the title played.

- (If connecting to a TV that supports VIERA Link with an HDMI cable)  
When [▶] (PLAY) is pressed on this unit’s remote control, you may not be able to see the beginning of the title played until the picture is displayed on the TV. Using [◀◀], return to the beginning of the title.

## Edit

### Available disc space does not increase even after deleting a title.

- Available disc space does not increase after deleting on DVD-R, DVD-R DL, +R or +R DL. (⇒ 19)
- Disc space increases only when the last recorded title is deleted on DVD-RW (DVD-Video format) and +RW. The disc space does not increase when any other titles are deleted.

### Cannot edit.

- You may not be able to edit on the HDD if there is no available space.  
Delete any unwanted titles to create empty space. (⇒ 19, 37, 57)

### Cannot format.

- The disc is dirty. Wipe with a damp cloth and then wipe dry. (⇒ 15)
- You tried formatting a disc that you may not be able to use in this unit. (⇒ 11–12)

### Cannot create chapters.

#### Cannot mark the start point or the end point during “Partial Delete” operation.

- The unit writes the chapter division information to the disc when you turn it off or remove the disc. The information is not written if there is an interruption to the power before this.
- These operations are not possible with still pictures.
- You cannot set points if they are too close to each other. You cannot set an end point before a start point.

### Cannot delete chapters.

- When the chapter is too short to delete, use “Combine Chapters” to make the chapter longer. (⇒ 37)

### Cannot create a Playlist (Video).

- You cannot select all the chapters at once in a title if the title also includes still pictures. Select them individually.

## Music

### Tracks could not be copied to the HDD.

- If there are copyright protected tracks such as SCMS restrictions, they will not be copied.
- Recording from CDs that do not conform to CD-DA specifications (copy control CDs, etc.) cannot be guaranteed.
- Bonus tracks may not be copied.

### ID3 tag of a MP3 file is not completely displayed.

- Only the track name (**HDD USB**) and artist name (**HDD**) can be displayed with this unit.

## Still pictures

### Cannot display DIRECT NAVIGATOR screen.

- This screen cannot be displayed during recording or copy or while the unit is standing by for linked timer recording with external equipment.

### Still pictures (JPEG) do not playback normally.

- The images that were edited on the PC, such as PROGRESSIVE JPEG etc., may not playback. (⇒ 14)

## USB

### The contents of the USB memory cannot be read.

- Remove the USB memory from the USB port and then insert again. If this does not solve the problem, turn off and turn on the unit again.
- Check that the USB memory is inserted correctly. (⇒ 15)
- The format of the USB memory or of its contents is not compatible with the unit. (The contents on the USB memory may be damaged.) (⇒ 13, 14)
- The USB memory contains a folder structure and/or file extensions that are not compatible with this unit. (⇒ 14)
- Turn off and then turn on the unit again.
- USB memories connected using a USB extension cable or a USB hub may not be recognized by this unit.
- Some USB memories cannot be used with this unit. (⇒ 13)
- If inserted during playback, recording or copying etc., the USB memory may not be recognized by this unit.

## Digital broadcast

### Digital broadcasts cannot be received.

- Digital broadcast may not have started in your region yet.
- The aerial may not be pointing in the direction of the TV station, or the direction of the aerial may have changed due to strong winds or vibration. If problem persists consult your local TV aerial installer.

### After DVB Auto Setup only some or no DVB channels are found.

- Check to ensure your area is covered by DVB transmissions.
- Check that the aerial and antenna cable are designed for DVB. If you live within 5-10 km of DVB transmission towers, a combined VHF/UHF aerial should be adequate. Outside this area, separate VHF and UHF aerials provide superior reception performance. (⇒ 8)

### Picture regularly breaks up on some channels. "No Signal" message is displayed.

- Check "Signal Condition". If "Signal Quality" or "Signal Strength" are displayed in red or constantly changing, check aerial. If problem persists consult your local TV aerial installer. (⇒ 60)
- Check that the aerial and antenna cable are designed for DVB.
- Interference (known as impulse noise) from household appliances such as light switches, fridges etc. may cause picture break up and/or audio distortion. Use a high quality quad shielded coaxial cable fly lead between this unit and antenna wall socket to minimise impulse noise pickup. If problem persists consult your local TV aerial installer.
- Check aerial connection.
- Adjust the aerial reception with "DVB Manual Tuning" in the Setup menu. (⇒ 59)

### Picture very infrequently breaks up on some or all channels.

- Electrical atmospheric interference caused by local or distant lighting storms or heavy rain with wind in "leafy" locations may cause pictures to break up and audio to mute or distort momentarily.
- Impulse noise interference from an infrequently used electrical appliance, or a passing vehicle or lawn mower with a "noisy" ignition system.

### Data broadcasts cannot be received.

- If Italy is selected in Country setting, data broadcasts cannot be received.

## VIERA Link

### VIERA Link doesn't work.

- Check the HDMI cable connection. Check that "HDMI" is displayed on the front display when the power for the main unit is set to On.
- Make sure that "VIERA Link" is set to "On". (⇒ 63)
- Check the "HDAVI Control" settings on the connected device.
- Some functions may not work if depending on the version of "HDAVI Control" of the connected equipment. This unit supports "HDAVI Control 5" functions.
- If the connection for the equipment connected with HDMI was changed, or if there was a power failure or the plug was removed from the household mains socket, "HDAVI Control" may not work.

In this case, perform the following operations.

- 1 When the HDMI cable is connected to all equipment with the power on, turn the TV (VIERA) on again.
- 2 Change the TV (VIERA) settings for the "HDAVI Control" function to off, and then set to on again. (For more information, see the VIERA operating instructions.)
- 3 Switch the VIERA input to HDMI connection with this unit, and after this unit's screen is displayed check that "HDAVI Control" is working.

### The operation on this unit (music playback etc.) is interrupted.

- The operation on this unit may be interrupted when you press buttons on the TV remote control that do not work for VIERA Link functions.

## To reset this unit

### To return all the settings other than the main ones to the factory preset

- Select "Yes" in "Shipping Condition" in the Setup menu. All the settings except for the ratings level, ratings PIN, language settings, Slideshow Settings and clock settings, etc. return to the factory preset. The timer recording programmes are also cancelled. (⇒ 65)
- Select "Yes" in "Default Settings" in the Setup menu. All the settings other than the tuning settings, clock settings, country settings, language settings, disc language settings, ratings level, ratings PIN, remote control code, etc. return to the factory presets. The timer recording programmes are also cancelled. (⇒ 65)
- Press and hold [√ CH] and [CH ^] on the main unit until the country setting screen appears. All the settings except for the ratings level, ratings PIN, remote control code and clock settings, etc. return to the factory preset. The timer recording programmes are also cancelled.

### To reset the ratings level settings

- While the disc tray is open, press [DRIVE SELECT] to select the DVD drive, then press and hold [● REC] and [▶] on the main unit at the same time for 5 or more seconds.

### To restore the unit if it freezes due to one of the safety devices being activated

- Press and hold [⏻/|] on the main unit for 3 seconds. (The settings remain.)

## Other

### After performing an update, you can no longer receive broadcasts.

- Depending on the content of the update, some settings may have returned to the preset values. Fix the settings again.

# Specifications

**Recording system** DVD-RAM : DVD Video Recording format  
 DVD-R : DVD-Video format  
 DVD-R DL (Dual Layer) : DVD-Video format  
 DVD-RW : DVD-Video format  
 +R  
 +R DL (Double Layer)  
 +RW

**Recordable discs**  
 DVD-RAM: 2X SPEED (Ver. 2.0),  
 2-3X SPEED (Ver. 2.1), 2-5X SPEED (Ver. 2.2)  
 DVD-R: 1X SPEED (Ver. 2.0), 1-4X SPEED (Ver. 2.0),  
 1-8X SPEED (Ver. 2.0), 1-16X SPEED (Ver. 2.1)  
 DVD-R DL (Dual Layer): 2-4X SPEED (Ver. 3.0), 2-8X SPEED (Ver. 3.0)  
 DVD-RW: 1X SPEED (Ver. 1.1), 1-2X SPEED (Ver. 1.1),  
 2-4X SPEED (Ver. 1.2), 2-6X SPEED (Ver. 1.2)  
 +R: 2.4X SPEED (Ver. 1.0), 2.4-4X SPEED (Ver. 1.1),  
 2.4-8X SPEED (Ver. 1.2), 2.4-16X SPEED (Ver. 1.3)  
 +R DL: 2.4X SPEED (Ver. 1.0), 2.4-8X SPEED (Ver. 1.1)  
 +RW: 2.4X SPEED (Ver. 1.1), 2.4-4X SPEED (Ver. 1.2)

**Recording time** Maximum 8 hours (using 4.7 GB disc)  
 XP: Approx. 1 hour, SP: Approx. 2 hours  
 LP: Approx. 4 hours, EP: Approx. 6 hours/8 hours  
 Maximum Approx. 279 hours with 160 GB HDD (EP 8 hours mode)  
 XP: Approx. 35 hours, SP: Approx. 70 hours  
 LP: Approx. 140 hours, EP: Approx. 209 hours/279 hours

**Playable discs**  
 DVD-RAM : DVD Video Recording format, JPEG  
 DVD-R : DVD-Video format, MP3\*1, JPEG\*1, DivX\*1  
 DVD-R DL (Dual Layer) : DVD-Video format,  
 MP3\*1, JPEG\*1, DivX\*1  
 DVD-RW : DVD-Video format, DVD Video Recording format  
 +R, +R DL (Double Layer), +RW  
 DVD-Video, CD-Audio (CD-DA), Video CD, SVCD\*2  
 CD-R/CD-RW : CD-DA\*1, Video CD\*1, SVCD\*1\*2, MP3\*1,  
 JPEG\*1, DivX\*1

**Internal HDD capacity** 160 GB

**Optical pick-up** System with 1 lens, 2 integration units  
 (662 nm wavelength for DVDs, 780 nm wavelength for CDs)

**LASER specification**  
 Class 1 LASER Product (Pickup)  
 Wave length:  
 CD 780 nm wave length  
 DVD 662 nm wave length  
 Laser power:  
 No hazardous radiation is emitted with the safety protection

**Audio**  
 Recording system: Dolby Digital 2ch, Linear PCM (XP mode)  
 Audio in: AV1/AV2 (21 pin)  
 Input level: Standard: 0.5 Vrms, Full scale: 2.0 Vrms at 1 kHz  
 Input impedance: More than 10 kΩ  
 Audio out: AV1/AV2 (21 pin), Audio Out (pin jack)  
 Output level: Standard: 0.5 Vrms, Full scale: 2.0 Vrms at 1 kHz  
 Output impedance: Less than 1 kΩ  
 Digital audio out: Optical terminal (PCM, Dolby Digital, DTS, MPEG)

**HDMI Output** 19 pin type A: 1 pc  
 HDMI™ (V.1.3a with Deep Colour)  
 • This unit supports "HDAVI Control 5" function.

**Video**  
 Video system:  
 SECAM (only input)/PAL colour signal, 625 lines, 50 fields  
 NTSC colour signal, 525 lines, 60 fields  
 Recording system: MPEG2 (Hybrid VBR)  
 Video in (PAL/SECAM/NTSC):  
 AV1/AV2 (21 pin), 1 Vp-p 75 Ω, termination  
 S-Video in (PAL/SECAM/NTSC):  
 AV2 (21 pin), 1 Vp-p 75 Ω, termination  
 Video out (PAL/NTSC):  
 AV1/AV2 (21 pin), Video Out (pin jack) 1 Vp-p 75 Ω, termination  
 S-Video out (PAL/NTSC): AV1 (21 pin), 1 Vp-p 75 Ω, termination  
 RGB out (PAL/NTSC):  
 AV1 (21 pin) 0.7 Vp-p (PAL) 75 Ω, termination

## Television system

Tuner system	Channel coverage
DVB-T (France)	VHF: 5-10 UHF: 21-69
DVB-T (Italy)	VHF: D-H2 UHF: 21-69
DVB-T (Spain)	VHF: 5-12 UHF: 21-69

RF converter output: Not provided

**USB port** Type A : 1 pc  
 USB standard: USB 2.0 High Speed  
 Format: FAT16, FAT32  
 Video (SD Video)\*3  
 Codec: MPEG 2 (SD-Video Entertainment Video Profile)  
 File Format: SD-Video format conforming

**Others**  
 Region code: # 2  
 Operating temperature: 5 °C to 40 °C  
 Operating humidity range: 10 % to 80 % RH (no condensation)  
 Power supply: AC 220 to 240 V, 50 Hz  
 Power consumption: Approx. 31 W  
 Dimensions (W×H×D): 430 mm×59 mm×286 mm  
 Mass: Approx. 3.5 kg

**Power consumption in standby mode:**  
**Approx. 0.3 W ("Power Save in Standby" is activated and "RF OUT ( Aerial Signal )" is set to "Off".)**  
**Approx. 11 W ("Power Save in Standby" is not activated.)**

**Note**  
 Specifications are subject to change without notice.  
 \*1 Finalising is necessary for compatible playback.  
 \*2 Conforming to IEC62107  
 This unit is not compatible with "Chaoji Video CD" available on the market including CVD, DVCD and SVCD that do not conform to IEC62107.  
 \*3 Video Recording conversion and transfer is possible from Panasonic digital video camera with HDD etc, to HDD or DVD-RAM disc.  
 After Video Recording conversion and transfer to HDD or DVD-RAM disc, the playback is possible.

Manufactured under license from Dolby Laboratories.  
 Dolby and the double-D symbol are trademarks of Dolby Laboratories.

Manufactured under license under U.S. Patent #'s: 5,451,942; 5,956,674; 5,974,380; 5,978,762; 6,487,535 & other U.S. and worldwide patents issued & pending. DTS and the Symbol are registered trademarks, & DTS 2.0+ Digital Out and the DTS logos are trademarks of DTS, Inc. Product includes software. © DTS, Inc. All Rights Reserved.

This product incorporates copyright protection technology that is protected by U.S. patents and other intellectual property rights. Use of this copyright protection technology must be authorized by Macrovision, and is intended for home and other limited viewing uses only unless otherwise authorized by Macrovision. Reverse engineering or disassembly is prohibited.

HDMI, the HDMI Logo, and High-Definition Multimedia Interface are trademarks or registered trademarks of HDMI Licensing LLC in the United States and other countries.

HDAVI Control™ is a trademark of Panasonic Corporation.

The recording and playback of content on this or any other device may require permission from the owner of the copyright or other such rights in that content. Panasonic has no authority to and does not grant you that permission and explicitly disclaims any right, ability or intention to obtain such permission on your behalf. It is your responsibility to ensure that your use of this or any other device complies with applicable copyright legislation in your country. Please refer to that legislation for more information on the relevant laws and regulations involved or contact the owner of the rights in the content you wish to record or playback.

DivX® is a registered trademark of DivX, Inc., and is used under license.

## Bitstream

This is the digital form of multi-channel audio data (e.g., 5.1 channel) before it is decoded into its various channels.

## CPRM (Content Protection for Recordable Media)

CPRM is technology used to protect broadcasts that are allowed to be recorded only once. Such broadcasts can be recorded only with CPRM compatible recorders and discs.

## Decoder

A decoder restores the coded audio signals on DVDs to normal. This is called decoding.

## Deep Colour

This unit incorporates HDMI™ (V.1.3a with Deep Colour) technology that can reproduce greater colour gradation (4096 steps) when connected to a compatible TV. You can enjoy exceptionally rich, natural-looking colours, with smooth, detailed gradation and minimal colour banding. [A lower colour gradation (256 steps), without Deep Colour, will be reproduced if connected to a TV which does not support Deep Colour. The unit will automatically set appropriate output to suit the connected TV.]

## DivX

DivX is a popular media technology created by DivX, Inc. DivX media files contain highly compressed video with high visual quality that maintains a relatively small file size.

## Dolby Digital

This is a method of coding digital signals developed by Dolby Laboratories. Apart from stereo (2-channel) audio, these signals can also be multi-channel audio. A large amount of audio information can be recorded on one disc using this method.

When recording on this unit Dolby Digital (2 channel) is the default audio.

## Down-mixing

This is the process of remixing the multi-channel audio found on some discs into two channels. It is useful when you want to listen to the 5.1-channel audio recorded on DVDs through your television's speakers. Some discs prohibit down-mixing and this unit can then only output the front two channels.

## Drive

In the instance of this unit, this refers to the hard disk (HDD) and disc (DVD). These perform the reading and writing of data.

## DTS (Digital Theater Systems)

This surround system is used in many movie theaters. There is good separation between the channels, so realistic sound effects are possible.

## Dynamic range

Dynamic range is the difference between the lowest level of sound that can be heard above the noise of the equipment and the highest level of sound before distortion occurs.

Dynamic range compression means reducing the gap between the loudest and softest sounds. This means you can listen at low volumes but still hear dialogue clearly.

## Film and video

DVD-Videos are recorded using either film or video. This unit can determine which type has been used, then uses the most suitable method of progressive output.

Film:	Recorded at 25 frames per second (PAL discs) or 24 frames per second (NTSC discs). (NTSC discs recorded at 30 frames per second as well.) Generally appropriate for motion picture films.
Video:	Recorded at 25 frames/50 fields per second (PAL discs) or 30 frames/60 fields per second (NTSC discs). Generally appropriate for TV drama programmes or animation.

## Finalise

A process that makes play of a recorded CD-R, CD-RW, DVD-R, etc. possible on equipment that can play such media. You can finalise DVD-R, DVD-R DL, DVD-RW (DVD-Video format), +R, +R DL on this unit.

After finalising, the disc becomes play-only and you can no longer record or edit. However, finalised DVD-RW can be formatted for recording again.

## Folder

This is a place on the hard disk or disc where groups of data are stored together. In the case of this unit, it refers to the place where still pictures (JPEG) are stored.

## Formatting

Formatting is the process of making media such as DVD-RAM recordable on recording equipment.

You can format DVD-RAM, DVD-RW (only as DVD-Video format), +RW and the HDD or unused +R and +R DL on this unit. Formatting permanently deletes all contents.

## Frames and fields

Frames refer to the single images that constitute the video you see on your television. Each frame consists of two fields.



- A frame still shows two fields, so there may be some blurring, but picture quality is generally better.
- A field still shows less picture information so it may be rougher, but there is no blurring.

## HDD (Hard disk drive)

This is a mass data storage device used in computers, etc. A disk with a surface that has been treated with magnetic fluid is spun and a magnetic head is brought in close proximity to facilitate the reading and writing of large amounts of data at high speed.

## HDMI (High-Definition Multimedia Interface)

Unlike conventional connections, it transmits uncompressed digital video and audio signals on a single cable. This unit supports high-definition video output [720p (750p), 1080i (1125i), 1080p (1125p)] from HDMI AV OUT terminals. To enjoy high-definition video a high definition compatible television is required.

## JPEG (Joint Photographic Experts Group)

This is a system used for compressing/decoding colour still pictures. If you select JPEG as the storage system on digital cameras, etc., the data will be compressed to 1/10–1/100 of its original size. The benefit of JPEG is less deterioration in picture quality considering the degree of compression.

## LPCM (Linear PCM)

These are uncompressed digital signals, similar to those found on CDs.

## MPEG2 (Moving Picture Experts Group)

A standard for efficiently compressing and expanding colour video. MPEG2 is a compression standard used for DVD and satellite based digital broadcasting. This unit records programmes using MPEG2. SD Video files shot with a Panasonic SD video camera, etc. can be copied to the HDD or a DVD-RAM disc.

## MP3 (MPEG Audio Layer 3)

An audio compression method that compresses audio to approximately one tenth of its size without any considerable loss of audio quality.

## Pan&Scan/Letterbox

In general, DVD-Video are produced with the intention that they be viewed on a widescreen television (16:9 aspect ratio), so images often don't fit regular (4:3 aspect ratio) televisions. Two styles of picture, "Pan & Scan" and "Letterbox", deal with this problem.

Pan & Scan: The sides are cut off so the picture fills the screen.



Letterbox: Black bands appear at the top and bottom of the picture so the picture itself appears in an aspect ratio of 16:9.



## Playback control (PBC)

If a Video CD has playback control, you can select scenes and information with menus.

(This unit is compatible with version 2.0 and 1.1.)

### Protection

You can prevent accidental deletion by setting writing protection or deletion protection.

### RGB

This refers to the three primary colours of light, red (R), green (G), and blue (B) and also the method of producing video that uses them. By dividing the video signal into the three colours for transmission, noise is reduced for even higher quality images.

### Sampling frequency

Sampling is the process of converting the heights of sound wave (analog signal) samples taken at set periods into digits (digital encoding). Sampling frequency is the number of samples taken per second, so larger numbers mean more faithful reproduction of the original sound.

### Signal Quality

This is the guide for checking the aerial direction. The numbered values displayed do not indicate the strength of the signal, but the quality of the signal (the signal to noise ratio, or "S/N"). The channels you can receive are affected by weather conditions, seasons, time (day/night), region, length of the cable that is connected to the aerial, etc.

### Thumbnail

This refers to a miniature representation of a picture used to display multiple pictures in the form of a list.

### 1080i

In one high definition image, 1080 (1125) alternating scan lines pass every 1/50<sup>th</sup> of a second to create an interlace image. Because 1080i (1125i) more than doubles current television broadcasts of 480i (525i), the detail is much clearer and creates a more realistic and rich image.

### 1080p

In one high definition image, 1080 (1125) scan lines pass at the same time every 1/50<sup>th</sup> of a second to create a progressive image. Since progressive video does not alternate scan lines like interlace, there is a minimal amount of screen flicker.

### 720p

In one high definition image, 720 (750) scan lines pass at the same time every 1/50<sup>th</sup> of a second to create a progressive image. Since progressive video does not alternate scan lines like interlace, there is a minimal amount of screen flicker.

## Safety precautions

### Placement

Set the unit up on an even surface away from direct sunlight, high temperatures, high humidity, and excessive vibration. These conditions can damage the cabinet and other components, thereby shortening the unit's service life.

Do not place heavy items on the unit.

### Voltage

Do not use high voltage power sources. This can overload the unit and cause a fire.

Do not use a DC power source. Check the source carefully when setting the unit up on a ship or other place where DC is used.

### AC mains lead protection

Ensure the AC mains lead is connected correctly and not damaged. Poor connection and lead damage can cause fire or electric shock. Do not pull, bend, or place heavy items on the lead.

Grasp the plug firmly when unplugging the lead. Pulling the AC mains lead can cause electric shock.

Do not handle the plug with wet hands. This can cause electric shock.

### Foreign matter

Do not let metal objects fall inside the unit. This can cause electric shock or malfunction.

Do not let liquids get into the unit. This can cause electric shock or malfunction. If this occurs, immediately disconnect the unit from the power supply and contact your dealer.

Do not spray insecticides onto or into the unit. They contain flammable gases which can ignite if sprayed into the unit.

### Service

Do not attempt to repair this unit by yourself. If sound is interrupted, indicators fail to light, smoke appears, or any other problem that is not covered in these instructions occurs, disconnect the AC mains lead and contact your dealer or an authorized service centre. Electric shock or damage to the unit can occur if the unit is repaired, disassembled or reconstructed by unqualified persons.

Extend operating life by disconnecting the unit from the power source if it is not to be used for a long time.

### Information for Users on Collection and Disposal of Old Equipment and used Batteries



These symbols on the products, packaging, and/or accompanying documents mean that used electrical and electronic products and batteries should not be mixed with general household waste.

For proper treatment, recovery and recycling of old products and used batteries, please take them to applicable collection points, in accordance with your national legislation and the Directives 2002/96/EC and 2006/66/EC.

By disposing of these products and batteries correctly, you will help to save valuable resources and prevent any potential negative effects on human health and the environment which could otherwise arise from inappropriate waste handling.

For more information about collection and recycling of old products and batteries, please contact your local municipality, your waste disposal service or the point of sale where you purchased the items.

Penalties may be applicable for incorrect disposal of this waste, in accordance with national legislation.



#### For business users in the European Union

If you wish to discard electrical and electronic equipment, please contact your dealer or supplier for further information.

#### [Information on Disposal in other Countries outside the European Union]

These symbols are only valid in the European Union. If you wish to discard these items, please contact your local authorities or dealer and ask for the correct method of disposal.



#### Note for the battery symbol (bottom two symbol examples):

This symbol might be used in combination with a chemical symbol. In this case it complies with the requirement set by the Directive for the chemical involved.

Cd

<b>Adjust the audio quality</b> (Sound menu) . . . . .	<b>55</b>	<b>DVB Subtitle</b> Record with subtitle . . . . .	18	<b>Quick View</b> . . . . .	<b>26</b>
<b>Adjust the picture quality</b> (Picture menu) . . . . .	<b>54</b>	Select subtitle . . . . .	16, 55	<b>Ratings level</b> . . . . .	<b>61</b>
<b>Album (Music)</b> Edit . . . . .	41	Show subtitle . . . . .	16	<b>Recording</b> . . . . .	<b>18</b>
Play . . . . .	32	<b>Edit</b> Chapter . . . . .	36	Aspect . . . . .	20, 61
<b>Album (Still picture)</b> Edit . . . . .	40	Music on HDD . . . . .	41	Auto Renewal Recording . . . . .	25
Play . . . . .	30	Playlist . . . . .	39, 43	Direct TV Recording . . . . .	34
<b>Angle</b> . . . . .	<b>54</b>	Still picture . . . . .	40	External Link . . . . .	23
<b>Aspect</b> . . . . .	<b>10</b>	Title . . . . .	36	Flexible Recording . . . . .	22
<b>Audio</b> Digital broadcast (DVB Multi Audio) . . . . .	16, 18, 55, 60	<b>Enabling discs to be played on other equipment - Finalise</b> . . . . .	<b>58</b>	Mode . . . . .	21
Playback . . . . .	26	<b>Finalise</b> . . . . .	58, 78	Notes . . . . .	20
<b>Auto Standby</b> . . . . .	<b>65</b>	<b>Format</b> . . . . .	57, 78	Relief Recording . . . . .	25
<b>AV2 Settings</b> . . . . .	<b>64</b>	<b>FR (Flexible Recording Mode)</b> . . . . .	21, 22	Timer recording . . . . .	24–25
<b>Change Thumbnail</b> . . . . .	<b>37</b>	<b>FUNCTION MENU Display</b> . . . . .	7, 33, 62	<b>Remote control code</b> . . . . .	<b>64</b>
<b>Channel</b> Select . . . . .	16	<b>HDAVI Control</b> . . . . .	9, 34–35, 63	<b>Repeat Play</b> . . . . .	<b>32, 54</b>
Settings . . . . .	59	<b>HDMI</b> . . . . .	9, 63, 78	<b>Resume play function</b> . . . . .	<b>26</b>
<b>Chapter</b> . . . . .	<b>26, 36</b>	<b>High Speed Copy</b> . . . . .	<b>61</b>	<b>Screen Saver</b> . . . . .	<b>62</b>
<b>Chapter Creation</b> . . . . .	<b>36, 61</b>	<b>Initialize</b> . . . . .	<b>65</b>	<b>Select channel</b> . . . . .	<b>16</b>
<b>Chasing playback</b> . . . . .	<b>22</b>	<b>JPEG</b> . . . . .	14, 30–31, 78	<b>Setup menu</b> . . . . .	<b>59</b>
<b>Child Lock</b> . . . . .	<b>66</b>	<b>Language</b> Code list . . . . .	69	<b>Signal Condition</b> . . . . .	<b>60</b>
<b>Cleaning</b> Disc . . . . .	15	Disc menu . . . . .	61	<b>Simultaneous rec and play</b> . . . . .	<b>22</b>
Lens . . . . .	5	On-screen . . . . .	62	<b>Slideshow</b> . . . . .	30, 31, 43
Main unit . . . . .	5	Soundtrack . . . . .	54, 61	<b>Soundtrack</b> . . . . .	<b>54</b>
<b>Clock Settings</b> . . . . .	<b>64</b>	Subtitle . . . . .	54, 61	<b>Still picture</b> Copy . . . . .	50
<b>Connection</b> Aerial . . . . .	8, 67	<b>Linked timer recordings with external equipment (digital satellite receiver) —</b> <b>EXT LINK</b> . . . . .	23, 64	Edit . . . . .	40
Amplifier, receiver . . . . .	67	<b>LPCM</b> . . . . .	62, 78	Play . . . . .	30
Digital satellite receiver . . . . .	8, 67	<b>Manual Skip</b> . . . . .	<b>26</b>	<b>Subtitle</b> Digital broadcast (DVB Subtitle) . . . . .	16, 18, 55, 60
HDMI . . . . .	9	<b>Menu</b> DivX . . . . .	28–29	Disc . . . . .	54, 61
Television . . . . .	8, 9, 66–67	Music . . . . .	29	<b>Switch the audio/subtitles on the disc</b> (Disc menu) . . . . .	<b>54</b>
Video cassette recorder . . . . .	67	Setup . . . . .	59	<b>System Update</b> . . . . .	<b>65</b>
<b>Copy</b> Music . . . . .	52	<b>Mode</b> Recording . . . . .	21	<b>Time Slip</b> . . . . .	<b>26</b>
SD Video . . . . .	49	Still Mode . . . . .	61	<b>Tuning</b> Digital broadcast . . . . .	59
Still picture . . . . .	50	<b>Music</b> . . . . .	<b>14</b>	List of TV Reception Channels . . . . .	68
Title/Playlist (Video) . . . . .	45	Copy . . . . .	52	<b>TV System (PAL/NTSC)</b> . . . . .	<b>63</b>
<b>Copy (playlist)</b> . . . . .	<b>39, 43</b>	Play . . . . .	29, 32	<b>USB</b> Copy (Music) . . . . .	52
<b>Country setting</b> . . . . .	<b>10</b>	<b>Music on HDD</b> Copy . . . . .	52	Copy (Still picture) . . . . .	50, 51
<b>CPRM</b> . . . . .	<b>78</b>	Edit . . . . .	41	Insert . . . . .	15
<b>Create Chapter</b> . . . . .	<b>26, 37</b>	Play . . . . .	32	Play . . . . .	28
<b>Create playlists</b> . . . . .	<b>38, 42</b>	<b>Name</b> Album (Music) . . . . .	41	Supported formats . . . . .	13
<b>Delete</b> Album (Music) . . . . .	41	Album (Still picture) . . . . .	40	<b>VIERA Link</b> . . . . .	<b>9, 34–35, 63</b>
Album (Still picture) . . . . .	40	Disc . . . . .	57		
All titles . . . . .	57	Entering text . . . . .	44		
Chapter . . . . .	37, 39	Playlist . . . . .	39, 43		
Playlist . . . . .	39, 43	Title . . . . .	24, 37		
Still picture . . . . .	40, 43	Track . . . . .	41		
Title . . . . .	37	<b>New Channel</b> . . . . .	<b>16, 59</b>		
Track . . . . .	41	<b>On-screen</b> Language . . . . .	62		
<b>Digital Audio Output settings</b> . . . . .	<b>62, 63</b>	<b>Partial Delete</b> . . . . .	<b>37</b>		
<b>Digital broadcast</b> Digital channel information . . . . .	16	<b>Pause Live TV</b> . . . . .	<b>33</b>		
DVB Multi Audio . . . . .	16, 18, 55, 60	VIERA . . . . .	35		
DVB Subtitle . . . . .	16, 18, 55, 60	<b>Playlist</b> . . . . .	<b>38, 42</b>		
New Channel . . . . .	16, 59	<b>Power Save in Standby</b> . . . . .	<b>65</b>		
Recording . . . . .	18	<b>Properties</b> Music on HDD . . . . .	32		
Select the channel . . . . .	16	Playlist . . . . .	39, 43		
Signal Condition . . . . .	60	Still picture . . . . .	31, 40		
System Update . . . . .	65	Title . . . . .	37		
<b>DIRECT NAVIGATOR</b> . . . . .	<b>27, 30, 36, 40</b>	<b>Protection</b> Album (Still picture) . . . . .	40		
<b>Discs</b> . . . . .	<b>11–12</b>	Disc . . . . .	56		
<b>Display</b> Digital channel information . . . . .	16	Still picture . . . . .	40		
Status messages . . . . .	55	Title . . . . .	37		
<b>Divide Title</b> . . . . .	<b>37</b>	<b>Q Link</b> . . . . .	<b>34</b>		
<b>DivX</b> . . . . .	<b>14, 28–29, 78</b>				
<b>DVB Multi Audio</b> Record with selected audio . . . . .	18				
Select audio . . . . .	16, 55				



Environment friendly printed on chlorine free bleached paper.

**Panasonic Corporation**  
**Web Site:** <http://panasonic.net>

Pursuant to at the directive 2004/108/EC, article 9(2)  
Panasonic Testing Centre  
Panasonic Marketing Europe GmbH  
Winsbergweg 15, 22525 Hamburg, Germany



\*VQT2J39\*

VQT2J39  
F0110ST0