

Panasonic

Operating Instructions

Digital Cordless Phone

Model No. **KX-TG1311EG**
KX-TG1312EG
KX-TG1313EG

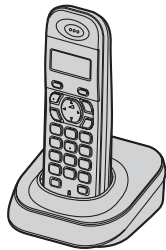

Model shown is KX-TG1311.

This unit is compatible with Caller ID. You must subscribe to the appropriate service offered by your service provider/telephone company.

Charge the batteries for about 7 hours before initial use.

Please read these operating instructions before using the unit and save them for future reference.

Table of Contents

Introduction	2
Preparation	5
Making/Answering Calls	10
Phonebook	11
Useful Telephone Settings	13
Caller ID Service	16
Multi-unit Operation	18
Useful Information.....	19



TG1311EG

PNQX1806ZA DC1008DQ0

Introduction

Product information

Thank you for purchasing a Panasonic digital cordless phone.

Important:

- The suffix (EG) in the following model numbers will be omitted in these instructions: KX-TG1311EG/KX-TG1312EG/KX-TG1313EG

General information

- In the event of problems, you should contact your equipment supplier in the first instance.

Declaration of Conformity:

- Panasonic Communications Co., Ltd. declares that this equipment is in compliance with the essential requirements and other relevant provisions of Radio & Telecommunications Terminal Equipment (R&TTE) Directive 1999/5/EC.
Declarations of Conformity for the relevant Panasonic products described in this manual are available for download by visiting:
<http://www.doc.panasonic.de>

Contact to Authorised Representative:
Panasonic Testing Centre
Panasonic Marketing Europe GmbH
Winsbergring 15, 22525 Hamburg, Germany

Model composition

KX-TG1311 series

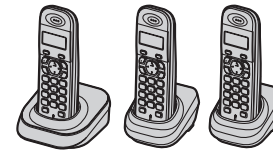

- Model shown is KX-TG1313.

Model No.	Base unit	Handset	
	Part No.	Part No.	Quantity
KX-TG1311	KX-TG1311	KX-TGA131	1
KX-TG1312	KX-TG1311	KX-TGA131	2
KX-TG1313	KX-TG1311	KX-TGA131	3

Supplied accessories

No.	Accessory item/Part number	Quantity		
		KX-TG1311	KX-TG1312	KX-TG1313
①	AC adaptor for base unit/ PQLV207CE	1	1	1
②	Telephone line cord	1	1	1
③	Rechargeable batteries*1	2	4	6
④	Handset cover*2	1	2	3
⑤	Charger	—	1	2
⑥	AC adaptor for charger/ PQLV209CE	—	1	2

*1 See page 3 for replacement battery information.

*2 The handset cover comes attached to the handset.

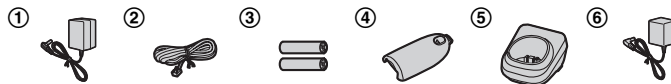

Replacement battery information:

- Replace batteries only with a nickel metal hydride (Ni-MH) type of battery. This model requires 2 AAA (R03) batteries for every handset. For best performance, we recommend using Panasonic rechargeable batteries (Model No. HHR-4MPT).
- Replacement batteries may have a different capacity from that of the supplied batteries.

Important information

General

- Use only the AC adaptor supplied with this product, noted on page 3.
- Do not connect the AC adaptor to any AC outlet other than a standard 220–240 V AC outlet.
- This product is unable to make calls when:
 - the portable handset battery(ies) need recharging or have failed.
 - there is a power failure.
 - the key lock feature is turned on.
 - the call bar feature is turned on (only phone numbers stored in the unit as emergency numbers can be called).
- Do not open the base unit, charger, or handset other than to replace the battery(ies).
- Consult the manufacturer of any personal medical devices, such as pacemakers or hearing aids, to determine if they are adequately shielded from external RF (radio frequency) energy. (The product operates in the frequency range of 1.88 GHz to 1.90 GHz, and the RF transmission power is 250 mW (max.)) Do not use the product in health care facilities if any regulations posted in the area instruct you not to do so. Hospitals or health care facilities may be using equipment that could be sensitive to external RF energy.
- Care should be taken that objects do not fall onto, and liquids are not spilled into, the product. Do not subject this product to excessive smoke, dust, mechanical vibration or shock.
- Only the supplied handset can be used with the base unit. No other handsets can be registered or used.

Environment

- Do not use this product near water.

Introduction

- This product should be kept away from heat sources such as radiators, cookers, etc. It should also not be placed in rooms where the temperature is less than 5 °C or greater than 40 °C.

Warning:

- To prevent the risk of electrical shock, do not expose this product to rain or any other type of moisture.
- Unplug this product from power outlets if it emits smoke, an abnormal smell, or makes unusual noise. These conditions can cause fire or electric shock. Confirm that smoke has stopped emitting and contact an authorised service centre.
- Do not spill liquids (detergents, cleansers, etc.) onto the telephone line cord plug, or allow it to become wet at all. This may cause a fire. If the telephone line cord plug becomes wet, immediately pull it from the telephone wall jack, and do not use.
- Do not place or use this product near automatically controlled devices such as automatic doors and fire alarms. Radio waves emitted from this product may cause such devices to malfunction resulting in an accident.
- Regularly remove any dust, etc. from the AC adaptor/power plug by pulling it from the power outlet, then wiping with a dry cloth. Accumulated dust may cause an insulation defect from moisture, etc. resulting in a fire.
- Do not damage the power cord/plug. This may cause a short circuit, electric shock, and/or fire.
- Do not touch the plug with wet hands.
- The AC adaptor is used as the main disconnect device. Ensure that the AC outlet is installed near the product and is easily accessible.

Battery caution

- We recommend using the battery(ies) noted on page 3. **USE ONLY rechargeable Ni-MH batteries AAA (R03) size.**
- Do not mix old and new batteries.
- Do not dispose of the battery(ies) in a fire, as they may explode. Check with local waste management codes for special disposal instructions.

- Do not open or mutilate the battery(ies). Released electrolyte from the battery(ies) is corrosive and may cause burns or injury to the eyes or skin. The electrolyte may be toxic if swallowed.
- Exercise care when handling the battery(ies). Do not allow conductive materials such as rings, bracelets or keys to touch the battery(ies), otherwise a short circuit may cause the battery(ies) and/or the conductive material to overheat and cause burns.
- Charge the battery(ies) provided with or identified for use with this product only in accordance with the instructions and limitations specified in this manual.
- Only use a compatible base unit (or charger) to charge the battery(ies). Do not tamper with the base unit (or charger). Failure to follow these instructions may cause the battery(ies) to swell or explode.

Notice for product disposal, transfer, or return

- This product can store your private/confidential information. To protect your privacy/confidentiality, we recommend that you erase the information such as phonebook or caller list entries from the memory before you dispose of, transfer, or return the product.

Information on Disposal in other Countries outside the European Union



These symbols are only valid in the European Union. If you wish to discard these items, please contact your local authorities or dealer and ask for the correct method of disposal.

Preparation

Connections

Base unit

The base unit can be mounted on the wall, if required.

- Use only the supplied Panasonic AC adaptor PQLV207CE.
- Use only the supplied telephone line cord. Using another telephone line cord may not allow the unit to work properly.

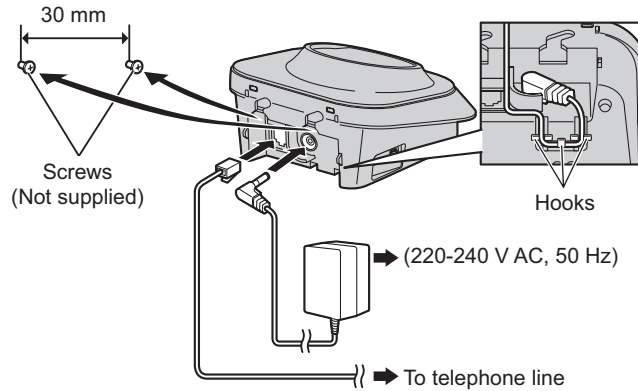

Charger

Available for:
KX-TG1312/KX-TG1313

The charger can be mounted on the wall, if required.

- Use only the supplied Panasonic AC adaptor PQLV209CE.

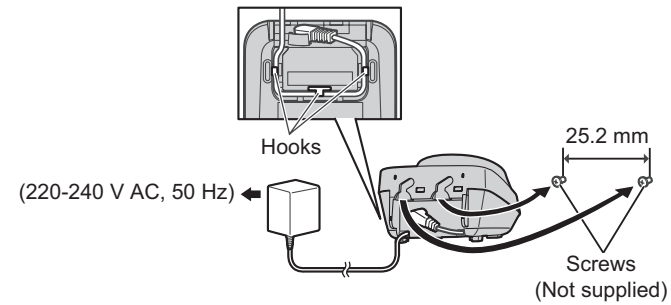

Note:

- Never install telephone wiring during a lightning storm.
- Do not connect the AC adaptor to a ceiling-mounted AC outlet, as the weight of the adaptor may cause it to become disconnected.

During a power failure

The unit will not work during a power failure. We recommend connecting a corded-type telephone (without AC adaptor) to the same telephone line or to the same telephone line jack using a T-adaptor.

Preparation

If you subscribe to a DSL/ADSL service

- Please attach a DSL/ADSL filter (contact your DSL/ADSL provider) to the telephone line between the base unit and the telephone line jack in the event of the following:
 - noise is heard during conversations.
 - Caller ID features do not function properly.

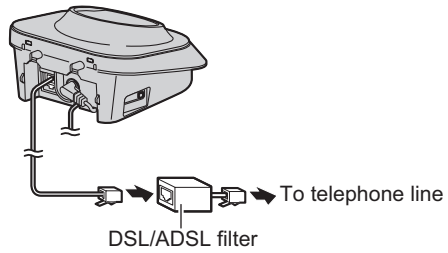

Location

- For maximum distance and noise-free operation, place your base unit:
- away from electrical appliances such as TVs, radios, personal computers, or other phones.
 - in a convenient, high, and central location.

Battery installation

Important:

- Use the supplied rechargeable batteries (Part No. HHR-55AAAB).
- When installing the batteries:
 - Wipe the battery ends (+, -) with a dry cloth.
 - Avoid touching the battery ends (+, -) or the unit contacts.
 - Confirm correct polarities (+, -).
- If the handset does not automatically turn on after installing batteries, press **[⏻]** for about 1 second, or place the handset on the base unit or charger.

Insert the batteries negative (-) end first. Close the handset cover.

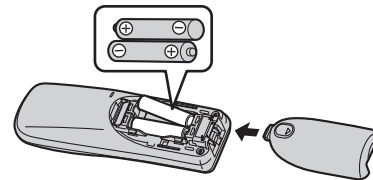

Turning the power on/off

Power on

Press **[⏻]** for about 1 second.

Power off

Press **[⏻]** for about 2 seconds.

Preparation

Battery charge

Place the handset on the base unit or charger for about 7 hours before initial use.

Battery level

Battery icon	Battery level
	High • When flashing: Fully charged.
	Medium
	Low • When flashing: Needs charging.

Panasonic Ni-MH battery performance (supplied batteries)

Operation	Operating time
In continuous use	17 hours max.
Not in use (standby)	150 hours max.

Note:

- It is normal for batteries not to reach full capacity at the initial charge. Maximum battery performance is reached after a few complete cycles of charge/discharge (use).
- Actual battery performance depends on a combination of how often the handset is in use and how often it is not in use (standby).
- Even after the handset is fully charged, the handset can be left on the base unit or charger without any ill effect on the batteries.

- The battery level may not be displayed correctly after you replace the batteries. In this case, place the handset on the base unit or charger and let it charge for at least 7 hours.

Controls

Handset

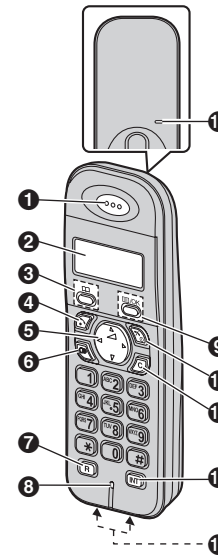

- 1 Receiver
- 2 Display
- 3 [☐] (Phonebook)
- 4 [↶] (Talk)
- 5 Navigator
([▲]/[▼]/[▶]/[◀])
△ (Volume: [▲]/[▼])
- 6 [●] (Redial/Pause)
- 7 [R] (Recall/Flash)
- 8 Microphone
- 9 [≡/OK] (Menu/OK)
- 10 [⏻] (Off/Power)
- 11 [C] (Clear)
- 12 [INT]
- KX-TG1311:
To stop paging
- KX-TG1312/KX-TG1313:
To stop paging/Intercom
- 13 Charge contacts
- 14 Ringer

Preparation

Base unit

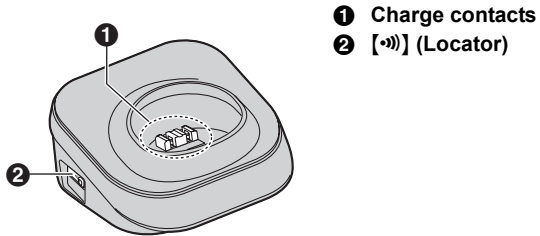

Display







Handset display items

Item	Meaning
	Within range of a base unit • When flashing: Out of range, no registration, or no power on base unit
	Paging, intercom mode, or accessing base unit
	Making or answering a call
	Phonebook mode
	Setting mode
	Battery level
	New voice mail message received.*1 (page 17)











Item	Meaning
	Call bar is on. (page 14)
	Direct call is on. (page 14)
	Key lock is on. (page 10)
	Ringer volume is off. (page 13)
	Displayed when you press [≡].
	If "BS NO" is selected for standby mode display (page 13) and the current base unit number is 1, "-1-" is displayed.
	If "HS NO" is selected for standby mode display (page 13) and the current handset number is 2, "[2]" is displayed.
	4 new calls When new calls have been received, the display shows the number of new calls.

*1 Voice mail subscribers only











Symbols used in these operating instructions

Symbol	Meaning
 /OK	Press  /OK.
→	Proceed to the next operation.
 /↑: “ ”	Press  or  to select the words in quotations. Example:  /↑: “OFF”

Display language

- 1 /OK
- 2 /↑: “SETTING HS” → 
- 3 /↑: “DISPLAY OPT” → 
- 4 /↑: “LANGUAGE” → 
- 5 /↑: Select your desired language. →  → /0

Note:









- If you select a language you cannot read: /0 → /OK →  →  →  3 times →  →  2 times →  → /↑: Select your desired language. →  → /0

Dialling mode









If you cannot make calls, change this setting according to your telephone line service. The default setting is Tone.

“1” (Tone): For tone dial service.

“2” (Pulse): For rotary/pulse dial service.

- 1 /OK
- 2 /↑: “SETTING BS” →  →  [3]
- 3 Enter base unit PIN (default: “0000”). →  [1]
 - If you forget your PIN, see page 21.
- 4 Select the desired setting by pressing  [1] for tone dialling mode or  [2] for pulse dialling mode.
- 5  → /0

Date and time

- 1 /OK
- 2 /↑: “SETTING BS” →  →  [✳]
- 3 Enter the current hour and minute (24-hour time entry).
 - If you make a mistake, press **[C]**. Digits are cleared from the right.
- 4 
 - A beep is heard.
- 5  →  [✳] 2 times
- 6 Enter the current date, month, and year.
 - If you make a mistake, press **[C]**. Digits are cleared from the right.
- 7  → /0

Making/Answering Calls

Making calls

- 1 Dial the phone number. → [↶]
- 2 When you finish talking, press [⏏] or place the handset on the base unit or charger.

Answering calls

- 1 Press [↶] to answer the call.
 - You can also answer the call by pressing any dial key from [0] to [9], [*], or [#]. (Any key answer feature)
- 2 When you finish talking, press [⏏] or place the handset on the base unit or charger.

Handset locator

- 1 Press [📞] on the base unit.
- 2 To stop paging, press [📞] on the base unit or press [↶] or [INT] on the handset.

Adjusting the receiver volume

Press [▲] or [▼] repeatedly while talking.

Pause (for PBX/long distance service users)

A pause is sometimes required when making calls using a PBX or long distance service. Pressing [⏏] 1 time creates a 3 second pause. Press [⏏] repeatedly to create longer pauses.

Redial functions (redialling/storing/editing before calling/erasing)

- 1 [⏏] → [▼]/[▲]: Select the desired phone number.
- 2 ■ **Redialling:**
[↶]
- **Storing:**
[▶] → [▼]/[▲]: "SAVE TEL NO" → [▶] → [☑/OK] → Enter the name (9 characters max.; page 11). → [☑/OK]
- **Editing before calling:**
[▶] → [▼]/[▲]: "EDIT CALL NO" → [▶] → Edit the number. → [↶]
- **Erasing:**
[▶] → [▼]/[▲]: "CLEAR"/"ALL CLEAR" → [▶] → [▼]/[▲]: "YES" → [▶] → [⏏]

Key lock

The handset can be locked so that no calls or settings can be made. Incoming calls can be answered, but all other functions are disabled while key lock is on.

Press [☑/OK] for about 2 seconds to turn key lock on/off.

Note:

- Calls to emergency numbers cannot be made until key lock is turned off.

Recall/flash

[R] allows you to use the special features of your host PBX such as transferring an extension call, or accessing optional telephone services.

Note:

- To change the recall/flash time, see page 15.

For call waiting or Call Waiting Caller ID service users

To use call waiting, you must first subscribe to the call waiting service of your service provider/telephone company.

This feature allows you to receive calls while you are already talking on the phone. If you receive a call while on the phone, you will hear a call waiting tone.

If you subscribe to both Caller ID and Call Waiting with Caller ID services, the 2nd caller's information is displayed after you hear the call waiting tone on the handset.

1 Press **[R]** to answer the 2nd call.

2 To switch between calls, press **[R]**.

Note:

- Please contact your service provider/telephone company for details and availability of this service in your area.

Temporary tone dialling (for rotary/pulse service users)

You can temporarily switch the dialling mode to tone when you need to access touch-tone services (for example, telephone banking services).

1 Make a call.

2 Press **[*]** when prompted to enter your code or PIN, then press the appropriate dial keys.

- The dialling mode will return to pulse when you hang up.

Adding entries to the phonebook

The phonebook allows you to make calls without having to dial manually. You can add 50 names and phone numbers.

1 **[☐/OK]** 2 times

2 Enter the party's phone number (24 digits max.). → **[☐/OK]**

3 Enter the party's name (9 characters max.). → **[☐/OK]**

4 **[*⓪]**

Note:

- When caller information is received and it matches a phone number stored in the unit's phonebook, the stored name is displayed.

Character table

Keys	Characters	Keys	Characters
[1]	# [] * , - / 1	[6]	M N O 6
[2]	A B C 2	[7]	P Q R S 7
[3]	D E F 3	[8]	T U V 8
[4]	G H I 4	[9]	W X Y Z 9
[5]	J K L 5	[0]	(Space) 0

Note:

- To enter another character located on the same dial key, press **[▶]** to move the cursor to the next space, then press the appropriate dial key.

Editing/correcting a mistake

1 Press **[◀]** or **[▶]** to move the cursor to the right of where you want to correct the number/character.

2 **[C]** → Enter the correct number/character.

Phonebook

Making calls/editing/erasing

- 1 [☐] → [▼]/[▲]: Select the desired entry.
- 2 ■ **Making calls:**
[↵]
- **Editing:**
[▶] → [▼]/[▲]: "EDIT" → [▶] → Edit the phone number. → [☑/OK] → Edit the name. → [☑/OK]
- **Erasing:**
[▶] → [▼]/[▲]: "CLEAR" → [▶] → [▼]/[▲]: "YES" → [▶] → [✕⊙]

One touch dialling (Hot key)

Assigning an entry in the phonebook to a one touch dial key

Dial keys [1] to [9] can each be used as a one touch dial key, allowing you to dial a number from the phonebook by simply pressing a dial key.

- 1 [☐] → [▼]/[▲]: Select the desired entry. → [☑/OK]
- 2 [▼]/[▲]: "HOT KEY REG" → [▶]
- 3 [▼]/[▲]: Select the desired dial key. → [▶]
 - If the dial key is already assigned as a one touch dial key, the displayed number flashes.
- 4 [▼]/[▲]: "YES" → [▶] → [✕⊙]

Making calls/cancelling a one touch dial assignment

- 1 Press and hold the desired one touch dial key ([1] to [9]).
- 2 ■ **Making calls:**
[↵]
- **Cancelling a one touch dial assignment:**
[▶] 2 times → [▼]/[▲]: "YES" → [▶] → [✕⊙]

Useful Telephone Settings

Guide to handset settings

To customise the handset (general approach):

- 1 [M]/[OK]
- 2 Press [▼] or [▲] to select "SETTING HS". → [▶]
- 3 Press [▼] or [▲] to select the desired item in the handset settings menu. → [▶]
- 4 Press [▼] or [▲] to select the desired item in the sub-menu. → [▶]
- 5 Press [▼] or [▲] to select the desired setting. → [▶]
 - This step may vary depending on the feature being programmed.
 - To exit the operation, press [X/O].

Note:

- In the following table, < > indicates the default settings.

Menu	Sub-menu	Page
TIME ALARM	SET TIME	13
	SET ALARM <OFF>	—
RINGER OPT	RINGER VOL <level 6>	—
	EXT RINGER*1 <RING TYPE 1>	—
	INT RINGER <RING TYPE 1>	—
	PAGING <RING TYPE 1>	—
	ALARM <RING TYPE 1>	—
TONE OPT	KEY TONE <ON>	—
	CALL WAITING <ON>	—
	RANGE ALARM <OFF>	—
	BATTERY LOW <ON>	—

Menu	Sub-menu	Page
DISPLAY OPT	STANDBY MODE <CLOCK>	—
	TALK MODE <TALK TIME>	—
	LANGUAGE <ENGLISH>	9
CALL OPT	CALL BAR <OFF>	14
	DIRECT NO	14
	SET DIRECT <OFF>	—
OTHER OPT	HSPIN CHANGE <0000>	14
	AUTO TALK*2 <OFF>	—
RESET HS	—	14

*1 If you select a melody for the external ringer tone, the ringer continues to sound until the melody finishes even when another person answers the call using another phone connected to the same line. If you want the handsets to stop ringing at the same time, select ringer tone number 1.

*2 Auto talk feature allows you to answer calls simply by lifting the handset off the base unit or charger. You do not need to press [M]. If you subscribe to a Caller ID service and want to view the caller's information after lifting up the handset to answer a call, turn off this feature.

Alarm

An alarm sounds at the set time for 3 minutes.

Important:

- Set the date and time beforehand (page 9).

- 1 [M]/[OK]
- 2 [▼]/[▲]: "SETTING HS" → [▶]
- 3 [▼]/[▲]: "TIME ALARM" → [▶]
- 4 [▼]/[▲]: "SET TIME" → [▶]

Useful Telephone Settings

- 5 Enter the desired hour and minute (24 hour time entry). → [▶]
- 6 [▼]/[▲]: Select the desired setting. → [▶] → [✕⊙]

Call bar

Call bar feature prohibits outside calls from being made. When call bar is turned on, only emergency calls can be made. To store emergency numbers, see page 15.

- 1 [≡/OK]
- 2 [▼]/[▲]: "SETTING HS" → [▶]
- 3 [▼]/[▲]: "CALL OPT" → [▶]
- 4 [▼]/[▲]: "CALL BAR" → [▶]
- 5 Enter handset PIN (default: "0000").
 - If you forget your PIN, see page 21.
- 6 [▼]/[▲]: Select the desired setting. → [▶] → [✕⊙]

Direct call

Direct call feature allows you to dial a preset phone number simply by pressing [↵]. No dialling is necessary.

- 1 [≡/OK]
 - 2 [▼]/[▲]: "SETTING HS" → [▶]
 - 3 [▼]/[▲]: "CALL OPT" → [▶]
 - 4 [▼]/[▲]: "DIRECT NO" → [▶]
 - 5 Enter a phone number (24 digits max.). → [≡/OK] 2 times
 - 6 [▼]/[▲]: "ON" → [▶] → [✕⊙]
- Note:**
- When this feature is turned on, only the direct call number can be called.

Changing the handset PIN

For security, the handset PIN must be entered when changing certain settings. If you change the PIN, please write down your new PIN as the unit will not reveal it to you again.

- 1 [≡/OK]
- 2 [▼]/[▲]: "SETTING HS" → [▶]
- 3 [▼]/[▲]: "OTHER OPT" → [▶]
- 4 [▼]/[▲]: "HSPIN CHANGE" → [▶]
- 5 Enter the current 4-digit handset PIN.
 - If you forget your PIN, see page 21.
- 6 Enter the new 4-digit handset PIN.
- 7 Enter the new 4-digit handset PIN again. → [✕⊙]

Resetting the handset

- 1 [≡/OK]
- 2 [▼]/[▲]: "SETTING HS" → [▶]
- 3 [▼]/[▲]: "RESET HS" → [▶]
- 4 Enter handset PIN (default: "0000").
 - If you forget your PIN, see page 21.
- 5 [▼]/[▲]: "YES" → [▶] → [✕⊙]

Useful Telephone Settings

Guide to base unit settings

To customise the base unit (general approach):

- 1 **[OK]**
- 2 Press **[▼]** or **[▲]** to select "SETTING BS". → **[▶]**
 - "INPUT CODE" is displayed.
- 3 Enter the desired code number. Follow the instructions in the "Feature" column of the chart.
 - To exit the operation, press **[*0]**.

Code No.	Feature (default setting)
[0]	Reset base unit to its default settings.*1 – Enter base unit PIN (default: "0000").*2 → [▶]
[3]	Dialling mode (Tone): page 9 Recall/flash time (600 ms)*3 – Enter base unit PIN (default: "0000").*2 → [2] → [1] – Select the desired setting by pressing [1] for 100 ms, [2] for 600 ms or [3] for 300 ms. → [▶] DTMF mode (Off): page 17
[5]	Change base unit PIN ("0000").*4 – Enter the current 4-digit base unit PIN.*2 – Enter the new 4-digit base unit PIN. – Enter the new 4-digit base unit PIN again.

Code No.	Feature (default setting)
[6]	Call restriction*5 ■ Setting call restriction <ul style="list-style-type: none"> – Enter base unit PIN (default: "0000").*2 → Enter the desired handset number by pressing the appropriate dial key. <ul style="list-style-type: none"> • The selected handset number flashes on the display. – [▶] – Enter the phone number to be restricted (8 digits max.). <ul style="list-style-type: none"> • To select a different memory location, press [▶] and enter a number. – [▶] ■ Turning on/off call restriction <ul style="list-style-type: none"> – Enter base unit PIN (default: "0000").*2 <ul style="list-style-type: none"> • Handset number is displayed. A flashing number indicates call restriction is on; a non-flashing number indicates call restriction is off. – Enter the desired handset number by pressing the appropriate dial key to turn on/off. → [▶] 2 times
	Emergency number*6 – Enter base unit PIN (default: "0000").*2 → [*] ■ Storing: <ul style="list-style-type: none"> – Enter the emergency number (8 digits max.). <ul style="list-style-type: none"> • To select a different memory location, press [▶] and enter a number. – [▶] ■ Editing: <ul style="list-style-type: none"> Press [▶] to display the desired number. → [C] → Enter the new emergency number. → [▶]

Code No.	Feature (default setting)
[*]	Date and time: page 9

- *1 Only the emergency number setting is not reset.
- *2 If you forget your PIN, see page 21.
- *3 The recall/flash time depends on your telephone exchange or host PBX. Contact your PBX supplier if necessary.
- *4 If you change the PIN, please write down your new PIN as the unit will not reveal it to you again.
- *5 Call restriction feature restricts the handset from dialling certain phone numbers. You can assign up to 10 phone numbers (memory locations 0–9) to be restricted.
- *6 Emergency number feature determines which phone numbers may be dialled while the call bar feature is turned on. A total of 4 emergency numbers (memory locations 1–4) can be stored.

Caller ID Service

Using Caller ID service

Important:

- This unit is Caller ID compatible. To use Caller ID features, you must subscribe to a Caller ID service. Contact your service provider/telephone company for details.

Caller ID features

Display indications

- When new calls have been received, the display shows the number of new calls.

Example: 4 new calls have been received.

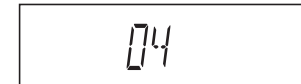

- Phone numbers of the last 50 different callers are logged in the caller list.

Example:

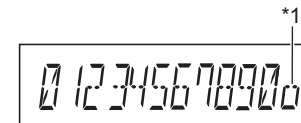







*1 Shown when this call has already been viewed or answered.

Press **[↶]** to call back.























- If the unit cannot receive caller information, the following is displayed:
 - “OUT OF AREA”: The caller dials from an area which does not provide a Caller ID service.
 - “PRIVATE”: The caller requests not to send caller information.

DTMF mode setting

Certain service providers/telephone companies send caller information between the first and second rings. If the display does not show caller information after a few rings, follow these instructions to set DTMF mode.

- 1 **[/OK]**
- 2 **[]/[]**: "SETTING BS" → **[]** → **[3]**
- 3 Enter base unit PIN (default: "0000"). → **[4]**
 - If you forget your PIN, see page 21.
- 4 Select DTMF mode by pressing **[2]**.
- 5 **[]** → **[]**
 - To cancel DTMF mode, press **[1]** in step 4.

Storing/editing/erasing



- 1 **[]/[]**: Select the desired entry. → **[]**
- 2 ■ **Storing:**
 - []/[]**: "SAVE TEL NO" → **[]** → **[/OK]** → Enter the party's name (9 characters max.; page 11). → **[/OK]** → **[]**
- **Editing:**
 - []/[]**: "EDIT CALL NO" → **[]** → Press **[]** or **[]** to move the cursor to the right of where you want to edit the number. → Edit the phone number. → **[]**
- **Erasing:**
 - []/[]**: "CLEAR"/"ALL CLEAR" → **[]** → **[]/[]**: "YES" → **[]** → **[]**

Voice mail service

Voice mail is an automatic answering service offered by your service provider/telephone company. After you subscribe to this service, your service provider/telephone company's voice mail system answers calls for you when you are unavailable to answer the phone or when your line is busy. Messages are recorded by your service provider/telephone company, not your telephone.

When you have new messages,  is displayed on the handset depending on your service provider/telephone company. Please contact your service provider/telephone company for details of this service.

Important:

- If  still remains on the display even after you have listened to new messages, turn it off by pressing **[]** for 1 second.

Multi-unit Operation

Intercom

Available for:
KX-TG1312/KX-TG1313

Intercom calls can be made between handsets.

Example: When handset 1 calls handset 2

- 1 Handset 1:**
[INT] → Press [2] (desired handset number).
- 2 Handset 2:**
[↶]
- 3** When you finish talking, press [⏏].

Transferring calls, conference calls

Available for:
KX-TG1312/KX-TG1313

Outside calls can be transferred between 2 handsets. 2 handsets can have a conference call with an outside party.

Example: When handset 1 transfers a call to handset 2

- 1 Handset 1:**
During an outside call, press [INT]. → Press [2] (desired handset number).
 - The outside call is put on hold.
 - If there is no answer, press [INT] to return to the outside call.
- 2 Handset 2:**
Press [↶] to answer the page.
 - Handset 2 can talk with handset 1.
- 3 Handset 1:**
To complete the call transfer, press [⏏].
To establish a conference call, press [3].

Transferring a call without speaking to the other handset user

- 1** During an outside call, press [INT]. → Enter the desired handset number.
 - [↶] flashes to indicate the outside call is on hold.
 - 2 [⏏]**
 - The outside call rings at the other handset.
- Note:**
- If the other handset user does not answer the call within 30 seconds, the call rings at your handset again.

Useful Information

Troubleshooting

If you still have difficulties after following the instructions in this section, disconnect the base unit's AC adaptor and turn off the handset, then reconnect the base unit's AC adaptor and turn on the handset.

Problem	Cause/solution
⏸ is flashing.	<ul style="list-style-type: none"> • The handset is too far from the base unit. Move closer. • The base unit's AC adaptor is not connected. Check the connections (page 5). • You are using the handset or base unit in an area with high electrical interference. Re-position the base unit and use the handset away from sources of interference. • The handset registration is cancelled. Register the handset to the base unit (page 21).

Problem	Cause/solution
I cannot make or receive calls.	<ul style="list-style-type: none"> • The base unit's AC adaptor or telephone line cord is not connected. Check the connections. • The call bar feature is turned on. Turn it off (page 14). • You dialled a call restricted number (page 15). • The key lock feature is turned on. Turn it off (page 10). • The dialling mode may be set incorrectly. Change the setting (page 9).
The unit does not ring.	<ul style="list-style-type: none"> • The ringer volume is turned off. Adjust the ringer volume (page 13).
The handset display is blank.	<ul style="list-style-type: none"> • The handset is not turned on. Turn the power on (page 6).
The handset will not turn on.	<ul style="list-style-type: none"> • Make sure that the batteries are installed correctly (page 6). • Fully charge the batteries (page 7).
I have changed the display language to a language I cannot read.	<ul style="list-style-type: none"> • Change the display language (page 9).
A busy tone is heard when [⏸] is pressed.	<ul style="list-style-type: none"> • The handset is too far from the base unit. Move closer and try again.

Useful Information

Problem	Cause/solution
Noise is heard, sound cuts in and out.	<ul style="list-style-type: none"> You are using the handset or base unit in an area with high electrical interference. Re-position the base unit and use the handset away from sources of interference. Move closer to the base unit. If you use a DSL/ADSL service, we recommend connecting a DSL/ADSL filter between the base unit and the telephone line jack. Contact your DSL/ADSL provider for details.
I fully charged the batteries, but  still flashes.	<ul style="list-style-type: none"> Clean the charge contacts and charge again (page 7). It is time to replace the batteries (page 6).
I fully charged the batteries, but the operating time seems to be shorter.	<ul style="list-style-type: none"> Clean the battery ends (+, -) and the charge contacts with a dry cloth, and charge again.

Problem	Cause/solution
Caller information is not displayed.	<ul style="list-style-type: none"> You must subscribe to a Caller ID service. Contact your service provider/telephone company for details. If your unit is connected to any additional telephone equipment, remove and plug the unit directly into the wall jack. If you use a DSL/ADSL service, we recommend connecting a DSL/ADSL filter between the base unit and the telephone line jack. Contact your DSL/ADSL provider for details. Other telephone equipment may be interfering with this unit. Disconnect the other equipment and try again.
Caller information is slow to display.	<ul style="list-style-type: none"> Depending on your service provider/telephone company, the unit may display the caller's information at 2nd ring or later. Move closer to the base unit.
I cannot remember the PIN.	<ul style="list-style-type: none"> Change the PIN using the instructions on page 21.

Useful Information**Liquid damage**

Problem	Cause/solution
Liquid or other form of moisture has entered the handset/base unit.	<ul style="list-style-type: none"> Disconnect the AC adaptor and telephone line cord from the base unit. Remove the batteries from the handset and leave to dry for at least 3 days. After the handset/base unit are completely dry, reconnect the AC adaptor and telephone line cord. Insert the batteries and charge fully before use. If the unit does not work properly, contact your nearest Panasonic service centre.

Caution:

- To avoid permanent damage, do not use a microwave oven to speed up the drying process.

Registering the handset to the base unit

- [/OK]
- []/[]: "SETTING HS" → []
- []/[]: "REGISTRATION" → []
- []/[]: "REGISTER HS" → []
- Press and hold [] on the base unit for about 5 seconds.
 - If all registered handsets start ringing, press [] to stop, then start again from step 1.
 - The rest of the procedure must be completed within 4 minutes.
- []/[]: Select a base unit number. → []
- Wait until "BS PIN" is displayed. → Enter the base unit PIN (default: "0000"). → []

- If you forget your PIN, see page 21.
- When the handset has been registered successfully, stops flashing.
- If is still flashing, start again from step 1.

Changing the handset PIN

- [/OK]
- []/[]: "SETTING HS" → []
- []/[]: "OTHER OPT" → []
- []/[]: "HSPIN CHANGE" → []
- [*][7][0][0][0]
- Enter the new 4-digit handset PIN.
- Enter the new 4-digit handset PIN again.
- []

Changing the base unit PIN

- [/OK]
- []/[]: "SETTING BS" → []
- [5]
- [*][7][0][0][0]
- Enter the new 4-digit base unit PIN.
- Enter the new 4-digit base unit PIN again.
- []

Useful Information

Specifications

- **Standard:**
DECT (Digital Enhanced Cordless Telecommunications)
- **Number of channels:** 120 Duplex Channels
- **Frequency range:** 1.88 GHz to 1.90 GHz
- **Duplex procedure:**
TDMA (Time Division Multiple Access)
- **Channel spacing:** 1,728 kHz
- **Bit rate:** 1,152 kbit/s
- **Modulation:**
GFSK (Gaussian Frequency Shift Keying)
- **RF transmission power:**
Approx. 10 mW (average power per channel)
- **Voice coding:** ADPCM 32 kbit/s
- **Power source:**
220–240 V AC, 50 Hz
- **Power consumption:**
Base unit:
Standby: Approx. 2.1 W
Maximum: Approx. 5.8 W
Charger*¹:
Standby: Approx. 0.8 W
Maximum: Approx. 5.0 W
- **Operating conditions:**
5 °C–40 °C, 20 %–80 % relative air humidity (dry)
- **Dimensions:**
Base unit: Approx. 103 mm × 104 mm × 58 mm
Handset: Approx. 148 mm × 50 mm × 33 mm
Charger*¹: Approx. 87 mm × 75 mm × 53 mm

■ Mass (weight):

- Base unit:** Approx. 120 g
- Handset:** Approx. 120 g
- Charger*¹:** Approx. 60 g

*1 KX-TG1312/KX-TG1313

Note:

- Design and specifications are subject to change without notice.
- The illustration in these instructions may vary slightly from the actual product.

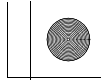
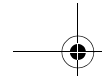
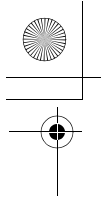

Notes

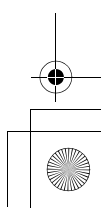
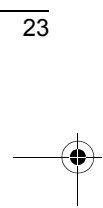
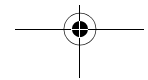
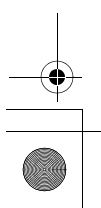
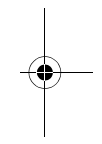
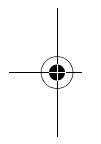

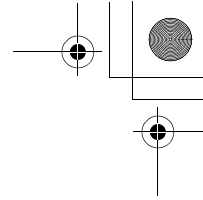
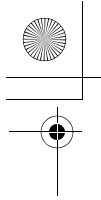

For your future reference

We recommend keeping a record of the following information to assist with any repair under warranty.

Serial No.	Date of purchase
(found on the bottom of the base unit)	
Name and address of dealer	

Attach your purchase receipt here.

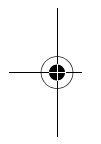

CE0470

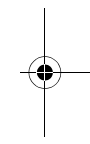

Panasonic Communications Co., Ltd.
 1-62, 4-chome, Minoshima, Hakata-ku, Fukuoka 812-8531, Japan

Copyright:
 This material is copyrighted by Panasonic Communications Co., Ltd., and may be reproduced for internal use only. All other reproduction, in whole or in part, is prohibited without the written consent of Panasonic Communications Co., Ltd.

© Panasonic Communications Co., Ltd. 2008

