



# Panasonic®

## Operating Instructions LCD Television

Model No. **TX-L26C10P**  
**TX-L26C10PS**  
**TX-L32C10P**  
**TX-L32C10PS**

# VIERA

**VIERA**  
Link



**HD**  
ready

**HDMI™**  
HIGH-DEFINITION MULTIMEDIA INTERFACE

Please read these instructions before operating your set and retain them for future reference.

The images shown in this manual are for illustrative purposes only.

Please refer to Pan European Guarantee Card if you need to contact your local Panasonic dealer for assistance.

English



TQB0E0821U

Turn your own living room into a movie theatre!

**Experience an amazing level of multi-**

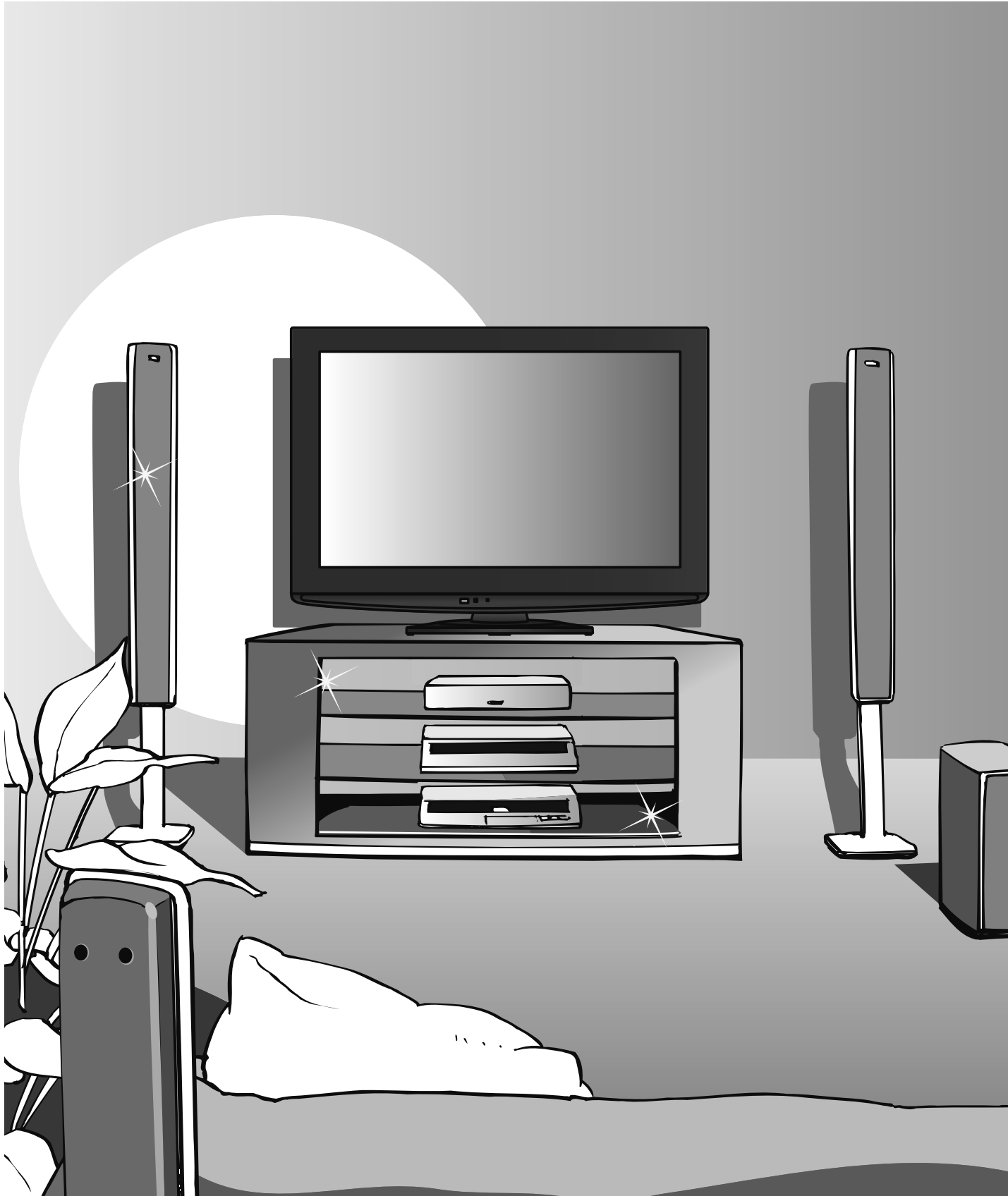

# media excitement

## Enjoy rich multi-media

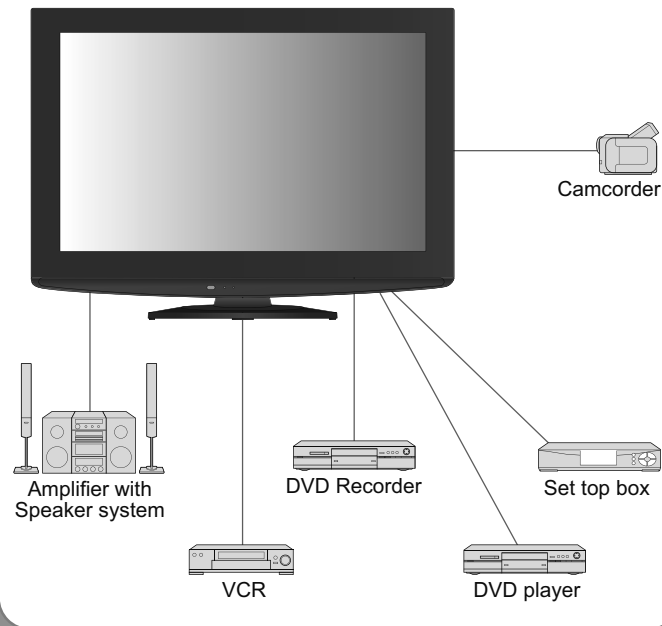

# Contents

## Be Sure to Read

- Safety Precautions ..... 4  
(Warning / Caution)
- Notes ..... 5
- Maintenance ..... 5

## Quick Start Guide

- Accessories / Options ..... 6
- Identifying Controls ..... 8
- Basic Connection ..... 10
- Auto Setup ..... 12

## Enjoy your TV!

### Basic Features

- Watching TV ..... 14
- Viewing Teletext ..... 16
- Watching Videos and DVDs ..... 18

### Advanced Features

- How to Use Menu Functions ..... 20  
(picture, sound quality, etc.)
- Editing Programmes ..... 24
- Tuning Programmes ..... 26
- Control Programme Audience ..... 28
- Restore Settings ..... 29
- Link Functions ..... 30  
(Q-Link / VIERA Link)
- External Equipment ..... 36

### FAQs, etc.

- Technical Information ..... 38
- FAQs ..... 41
- Licence ..... 43
- Specifications ..... 43

# Safety Precautions

## Warning

### Handling the mains plug and lead

- Insert the mains plug fully into the socket outlet. (If the mains plug is loose, it could generate heat and cause fire.)
- Ensure that the mains plug is easily accessible.
- Do not touch the mains plug with a wet hand. (This may cause electrical shock.)
- Do not damage the mains lead. (A damaged lead may cause fire or electrical shock.)
  - Do not move the TV with the lead plugged in the socket outlet.
  - Do not place a heavy object on the lead or place the lead near a high-temperature object.
  - Do not twist the lead, bend it excessively, or stretch it.
  - Do not pull on the lead. Hold onto the mains plug body when disconnecting lead.
  - Do not use a damaged mains plug or socket outlet.

If you find any abnormality, remove the mains plug immediately!

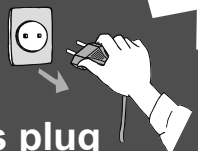

AC 220-240 V  
50 Hz

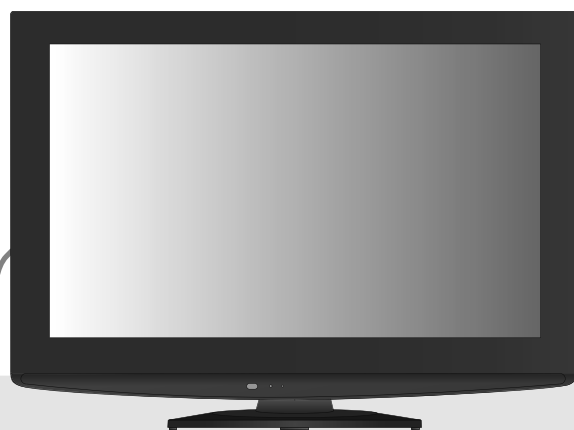

### Power source

- This TV is designed to operate on 220-240 V, 50 Hz AC.

### Do not remove covers NEVER modify the TV yourself

(High-voltage components may cause serious electrical shock.)

- Have the TV checked, adjusted, or repaired at your local Panasonic dealer.
- Do not remove the rear cover as live parts are accessible when it is removed. There are no user serviceable parts inside.

### Do not expose to rain or excessive moisture

- To prevent damage which might result in electric shock or fire, do not expose this TV to rain or excessive moisture.
- This TV must not be exposed to dripping or splashing water and objects filled with liquid, such as vases, must not be placed on top of or above the TV.

### Do not expose to direct sunlight and other sources of heat

- Avoid exposing the TV to direct sunlight and other sources of heat. To prevent fire never place any type of candle or naked flame on top or near the TV.

### Do not place foreign objects inside the TV

- Do not allow any objects to drop into the TV through the air vents (fire or electrical shock may result).

### Do not place the TV on sloped or unstable surfaces

- The TV may fall off or tip over.

### Use only the dedicated pedestals / mounting equipment

- Using an unapproved pedestal or other fixtures may make the TV unstable, risking injury. Be sure to ask your local Panasonic dealer to perform setup.
- Use approved pedestals / mounts (p. 6).

# Notes

## Caution

### ■ When cleaning the TV, remove the mains plug

- Cleaning an energized TV may cause electrical shock.

### ■ When the TV is not going to be used for a long period of time, remove the mains plug To prevent fall and injury, remove TV from its fixed wall position when it is no longer in use

- This TV will still consume some power even in the Off mode, as long as the mains plug is still connected to a live socket outlet.
- Remove the mains plug from the wall socket before connecting or disconnecting leads.

### ■ Allow sufficient space around the TV for radiated heat

Minimum distance

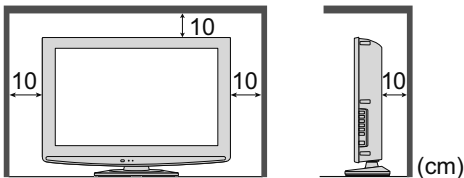

- When using the pedestal, keep the space between the bottom of the TV and the floor surface.
- In case of using Wall-hanging bracket, follow the manual of it.

### ■ Do not block the rear air vents

- Blocked ventilation by newspapers, table cloths, curtains, etc. may cause overheating, fire or electrical shock.

### ■ Do not expose your ears to excessive volume from the headphones

- Irreversible damage can be caused.

### ■ Auto power standby function

- If no signal is received and no operation is performed in Analogue TV mode for 30 minutes, the TV will automatically go to standby mode.

### ■ Keep the TV away from these types of equipment

- Electronic equipment  
In particular, do not place video equipment near the TV (electromagnetic interference may distort images / sound).
- Equipment with an infrared sensor  
This TV also emits infrared rays (this may affect operation of other equipment).

### ■ Transport only in upright position

# Maintenance

First, remove the mains plug from the socket outlet.

## Display panel

Regular care: Gently wipe the surface clean of dirt by using a soft cloth.

Major contamination: Wipe the surface clean using a soft cloth dampened with clean water or diluted neutral detergent (1 part detergent to 100 parts water). Then, using a soft dry cloth, evenly wipe the surface clean until it is dry.

### Caution

- The surface of the display panel has been specially treated and may be easily damaged. Do not tap or scratch the surface with your fingernail or other hard object.
- Take care not to subject the surface to insect repellent, solvent, thinner, or other volatile substances (this may degrade surface quality).

## Cabinet, Pedestal

Regular care: Wipe the surface clean using a soft dry cloth.

Major contamination: Dampen a soft cloth with clean water or water containing a small amount of neutral detergent. Then, wring the cloth and wipe the surface clean with it. Finally, wipe the surface clean with a dry cloth.

### Caution

- Take care not to subject the TV's surfaces to detergent. (A liquid inside the TV could lead to product failure.)
- Take care not to subject surfaces to insect repellent, solvent, thinner, or other volatile substances (this may deteriorate the surface by peeling the paint).
- Do not allow the cabinet and pedestal to make contact with a rubber or PVC substance for a long time.

## Mains plug

Wipe the mains plug with a dry cloth at regular intervals. (Moisture and dust may lead to fire or electrical shock.)

# Accessories / Options

## Standard accessories

- Remote Control
- N2QAYB000223



Check that you have the accessories and items shown

- Batteries for the Remote Control (2)
- R6 (UM3)

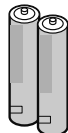

- Clamper

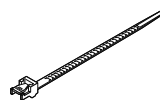

- Cleaning cloth (TX-L26C10P TX-L32C10P)



- Operating Instructions

- Pan European Guarantee Card

- Pedestal

- Assembly screw for Pedestal (4)

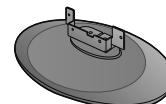
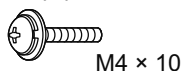

- This product contains possibly dangerous parts (such as plastic bags), that can be breathed in or swallowed by young children accidentally. Keep these parts out of reach of young children.

## Optional accessories

### Wall-hanging bracket

- TY-WK3L2RW or TY-WK32LR2W (for 26" and 32")
- or TY-WK32LR2W (for 26" only)

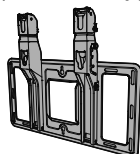
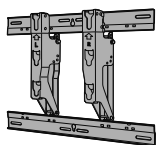

Please contact your nearest Panasonic dealer to purchase the recommended wall-hanging bracket. For additional details, please refer to the wall-hanging bracket installation manual.

### WARNING!

- Failure to use a Panasonic bracket or choosing to mount the unit yourself will be done at the risk of the consumer. Any damage resulting from not having a professional installer mount your unit will void your warranty.
- Always be sure to ask a qualified technician to carry out set-up. Incorrect fitting may cause equipment to fall, resulting in injury and product damage.
- Do not mount the unit directly below ceiling lights (such as spotlights, floodlights or halogen lights) which typically give off high heat. Doing so may warp or damage plastic cabinet parts.
- Take care when fixing wall brackets to the wall. Always ensure that there are no electrical cables or pipes in the wall before hanging bracket.

## Installing / removing remote's batteries

1

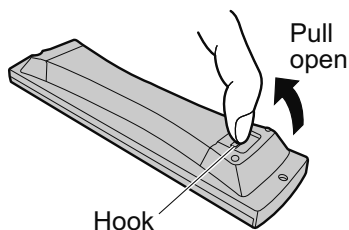

2

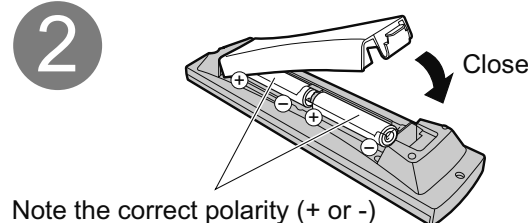

### Caution

- Incorrect installation may cause battery leakage and corrosion, resulting in damage to the remote control.
  - Do not mix old and new batteries.
  - Do not mix different battery types (such as alkaline and manganese batteries).
  - Do not use rechargeable (Ni-Cd) batteries.
  - Do not burn or breakup batteries.
- Batteries must not be exposed to excessive heat such as sunshine, fire or the like.

## Attaching the pedestal

### Warning

**Do not disassemble or modify the pedestal.**

- Otherwise the TV may fall over and become damaged, and personal injury may result.

### Caution

**Do not use any other TV and displays.**

- Otherwise the TV may fall over and become damaged, and personal injury may result.

**Do not use the pedestal if it becomes warped or physically damaged.**

- If you use the pedestal while it is physically damaged, personal injury may result. Contact your nearest Panasonic dealer immediately.

**During set-up, make sure that all screws are securely tightened.**

- If insufficient care is taken to ensure screws are properly tightened during assembly, the pedestal will not be strong enough to support the TV, and it might fall over and become damaged, and personal injury may result.

**Ensure that TV does not fall over.**

- If the TV is knocked or children climb onto the pedestal with the TV installed, the TV may fall over and personal injury may result.

**Two or more people are required to install and remove the TV.**

- If two or more people are not present, the TV may be dropped, and personal injury may result.

### ■ Securing the TV

Use only the supplied assembly screws to fasten securely.

- Make sure that the screws are securely tightened.
- Carry out the work on horizontal and level surface.

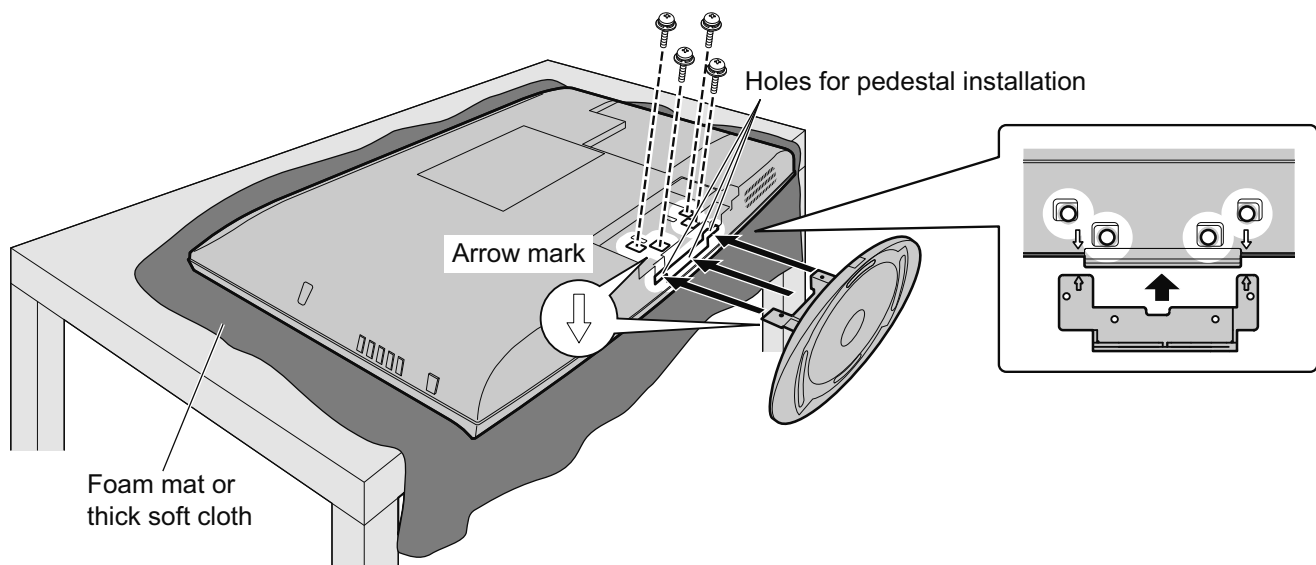

# Accessories / Options

## Using the clammer

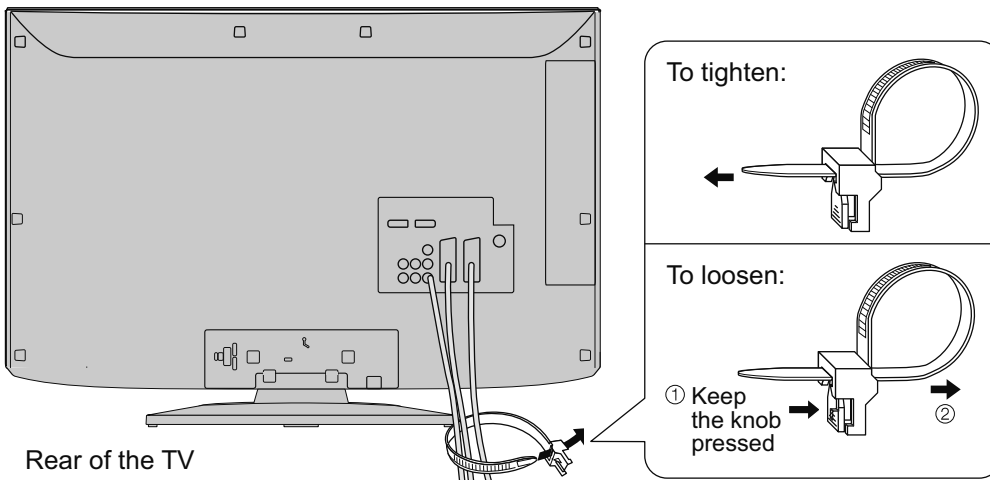

- Do not bundle the RF cable and mains lead together (could cause distorted image).
- Fix cables with clammers as necessary.
- When using the optional accessory, follow the option's assembly manual to fix cables.

# Identifying Controls

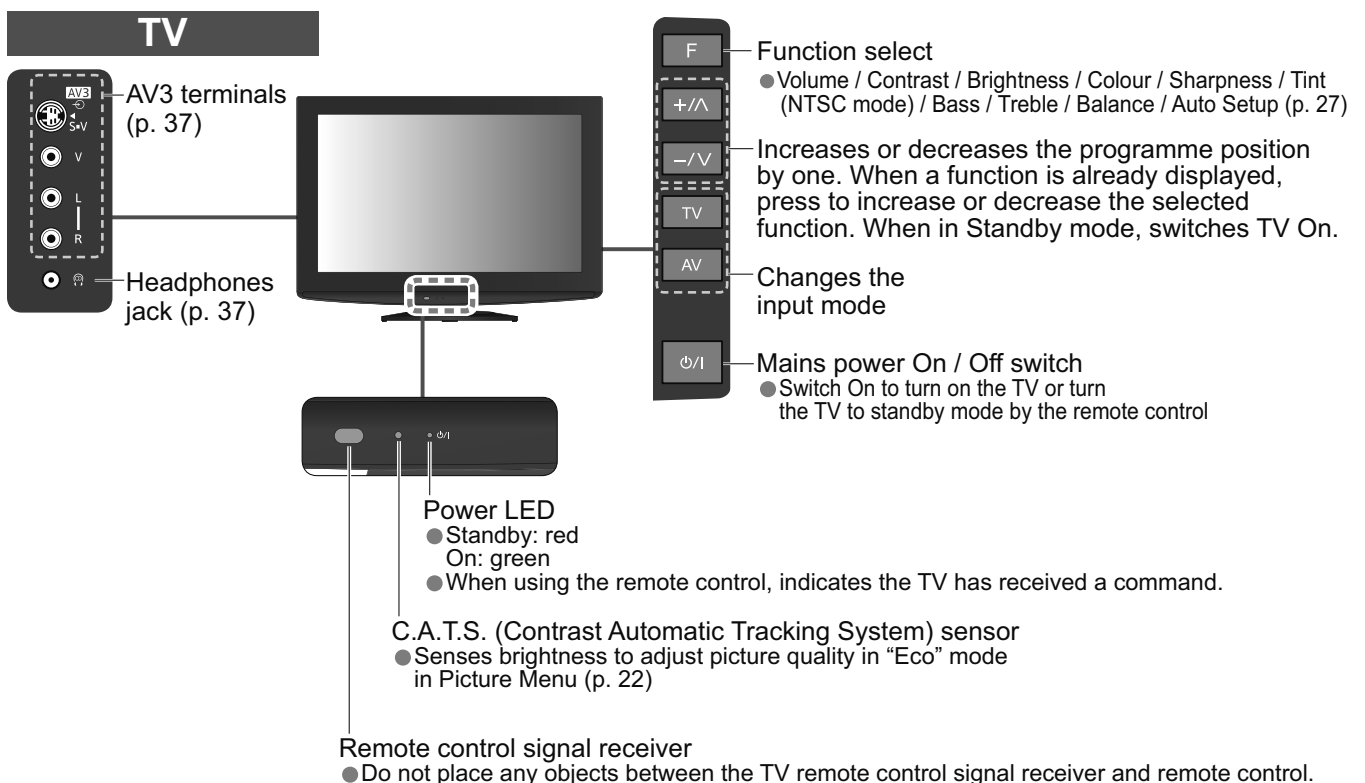

# Identifying Controls

## Remote Control

### Standby On / Off switch

- Switches TV On or Off standby

### Aspect (p. 15)

- Changes aspect ratio from Aspect Selection list
- Also possible by pressing this button repeatedly until you reach the desired aspect

### OK

- Confirms selections and choices
- Press after selecting programme positions to quickly change programme

### Main Menu (p. 20)

- Press to access VIERA Link, Picture, Sound and Setup Menus

### Surround (p. 22)

- Switches Surround On or Off

### VIERA Link Menu (p. 33)

- Press to access VIERA Link Menu directly

### Programme Information (p. 15)

- Displays programme information

### Programme Up / Down

- Selects programme in sequence

### Teletext (p. 16)

- Switches to teletext mode

### Favourite Page (p. 17)

- Calls up the teletext page stored in blue button

### VCR / DVD Panasonic equipment operations (p. 19)

### Input mode selection

- TV - switches to TV mode (p. 18)
- AV - switches to AV input mode from Input Selection list (p. 18)

### Exit

- Returns to the normal viewing screen

### Cursor buttons

- Makes selections and adjustments

### Return

- Returns to the previous menu

### Coloured buttons

- Used for the selection, navigation and operation of various functions

### Direct TV Recording (p. 31 and p. 33)

- Records programme immediately in DVD Recorder / VCR with Q-Link or VIERA Link connection

### Option Menu (p. 14)

- Easy setting for viewing and sound options

### Numeric buttons

- Changes programme and teletext pages
- When in Standby mode, switches TV On

### Sound Mute

- Switches sound mute On or Off

### Volume Up / Down

### Hold

- Freeze / unfreeze picture (p. 14)
- Holds the current teletext page (teletext mode) (p. 17)

### Index (p. 17)

- Returns to the teletext index page (teletext mode)



# Basic Connection

External equipment and cables shown are not supplied with this TV.  
Please ensure that the unit is disconnected from the mains socket before attaching or disconnecting any leads.

## Example 1 Connecting aerial

### TV only

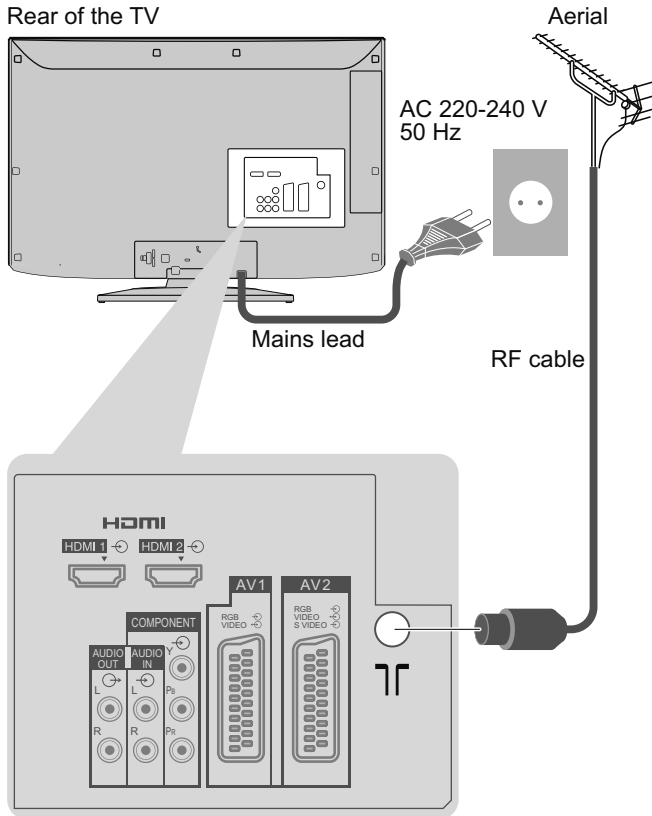

## Example 2 Connecting DVD Recorder / VCR

### TV, DVD Recorder or VCR

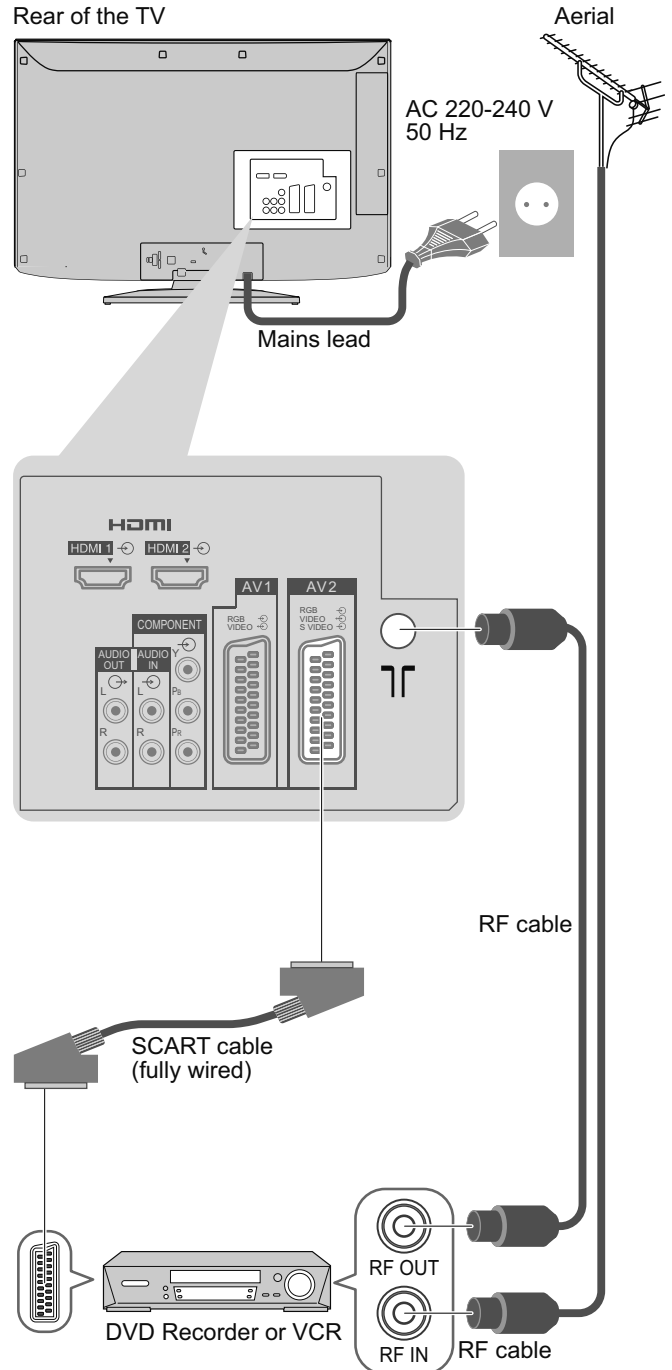

### Note

- Connect to AV1 / AV2 for a DVD Recorder / VCR supporting Q-Link (p. 31).
- For HDMI-compatible equipment, possible to connect to HDMI terminals (HDMI1 / HDMI2) by using HDMI cable (p. 36).
- Q-Link connection → p. 30
- VIERA Link connection → p. 30
- Read the manual of the equipment too.

## Example 3 Connecting DVD Recorder / VCR and Set top box

### TV, DVD Recorder / VCR and Set top box

Rear of the TV

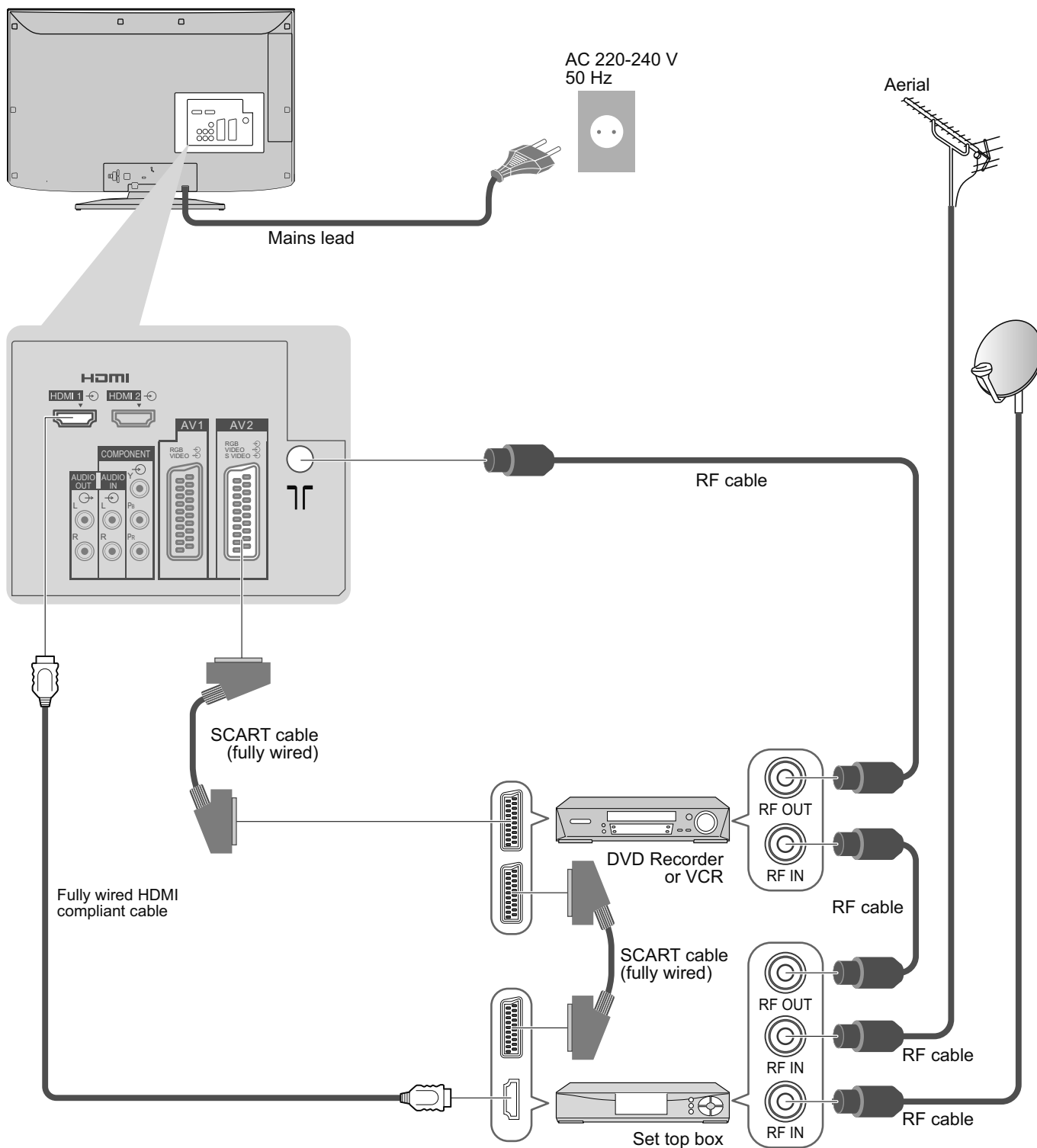

# Auto Setup

Search and store TV programmes automatically.

These steps are not necessary if the setup has been completed by your local dealer.

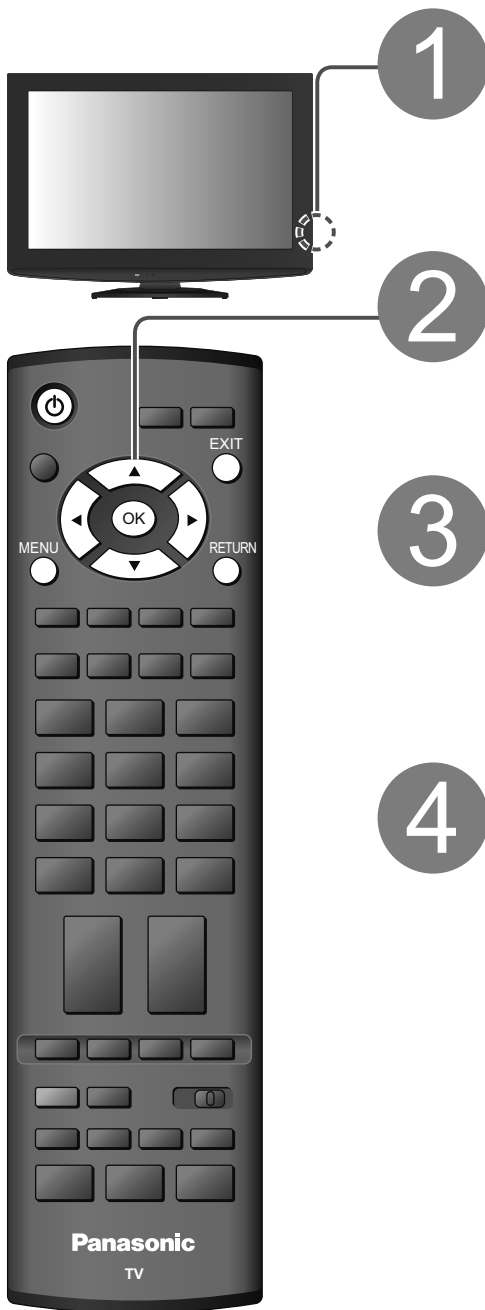

**1 Plug the TV into mains socket and switch On**  
(Takes a few seconds to be displayed)



- You can now use the remote control to turn On the TV or turn the TV to standby mode. (Power LED: On)

**2 Select the language**

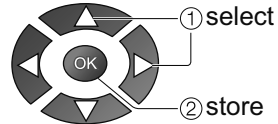

**3 Select your country**

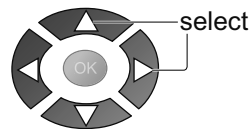

- Depending on the selected countries, you may also be required to select the region.

**4 Start Auto Setup**

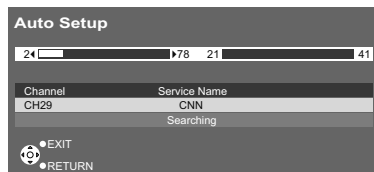

- Auto Setup will start to search for TV programmes and store them. The sorted programme order depends upon the TV signal, the broadcasting system and reception conditions.

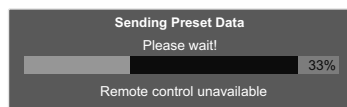

- If Q-Link, VIERA Link or similar technology (p. 30), compatible recorder is connected, programme, language, country / region settings are automatically downloaded to the recorder.

**5 Select the picture setting**

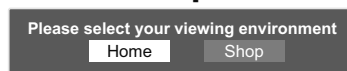

- “Shop” and “Home” are equal to “Dynamic” and “Normal” respectively - “Viewing Mode” in “Picture Menu” (p. 22)

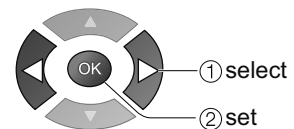

**Auto Setup is now complete and your TV is ready for viewing.**

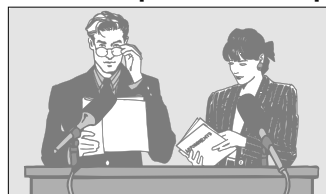

- To edit programmes → “Editing Programmes” (p. 24)

## Using the On Screen Displays

Many features available on this TV can be accessed via the On Screen Display menu.

### ■ How to use remote control



Open the main menu



Move the cursor / select the menu



Move the cursor / adjust levels / select from a range of options



Access the menu / store settings after adjustments have been made or options have been set



Return to the previous menu



Exit the menu system and return to the normal viewing screen

### ■ ON SCREEN HELP Instructions box (example: Sound Menu)

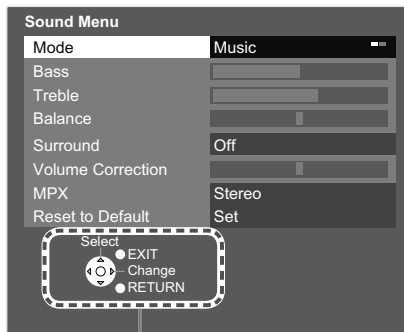

On-screen operation guide will help you.

#### Note

- If tuning has failed → “Auto Setup” (p. 27)
- If downloading has failed → “Download” (p. 23)
- To initialize all settings → “Shipping Condition” (p. 29)
- If you turned the TV Off during Standby mode last time, the TV will be in Standby mode when you turn the TV On with Mains power On / Off switch.

# Watching TV

**1 Turn power on**  
(Press for about 1 second)

- Mains power On / Off switch should be On. (p. 8)

**2 Select a programme**

- To select the two-digit programme number, e.g. 39  
 → 3 → 9  
 (in a short time)
- To select from the Programme List  
 → OK

Information banner appears whenever you select a programme  
 ● For details → p. 15

Volume

**■ Select a programme using Information banner (p. 15)**  
 Possible to confirm the programme name before selecting programmes.

Display Information banner if it is not displayed

While the banner is displayed, select the programme

## Other useful functions

<b>Hold</b>	<b>Freeze / unfreeze picture</b>	<b>HOLD</b> 
<b>Display the selectable settings for the current programme</b>	<b>Check or change the current programme status instantly</b>	<b>OPTION</b>  ● To change →  ② change ① select
	<b>Teletext Character</b> Sets the teletext language → Setup Menu (p. 23) <b>MPX</b> → Sound Menu (p. 22) <b>Note</b> ● Also possible to change the settings in Menu list (p. 22 and p. 23).	<b>Volume Correction</b> Adjusts volume of individual programme or input mode
<b>Off Timer</b>	<b>Turn the TV off automatically after a fixed period</b> Display the menu → Select "Setup" → Select "Off Timer" and set the time →  →  ② access ① select →  →  ② set ① select	
	● To cancel → Set to "Off" or turn the TV off. ● To display the remaining time → Information banner (p. 15) ● When the remaining time is within 3 minutes, the remaining time will flash on screen.	

Other useful functions

Display Information banner

Display Information banner

- Also appears when changing a programme

Example: Programme

1

Event — Coronation Street  
CH05 SC1 PAL

Sound System Colour System

Features available / Message meanings

Sound mute On  
**Stereo, Mono**  
 Audio mode

**1 - 90**  
 Off Timer remaining time  
 ● For settings → p. 14

- To confirm another tuned programme name → select programme
- To watch the programme listed in the banner → ● Event information is referred to teletext signal.
- To hide → ●

Change the aspect ratio

Enjoy viewing the picture at its optimum size and aspect.  
 Display Aspect Selection list → While the list is displayed, select the mode



- To change the mode using the ASPECT button only → (Press repeatedly until you reach the desired mode)

<p>Auto</p> <p>The best ratio is chosen and the picture expanded to fill the screen. For details → p. 38</p>	<p>16:9</p> <p>Directly displays the image at "16:9" without distortion (anamorphic).</p>
<p>14:9</p> <p>Displays the image at the standard "14:9" without distortion.</p>	<p>Just</p> <p>Displays a "4:3" image full-screen. Stretching is only noticeable at the left and right edges.</p>
<p>4:3</p> <p>Displays the image at the standard "4:3" without distortion.</p>	<p>4:3 Full</p> <p>Displays a "4:3" image enlarged horizontally to fit the screen. ● HD signal only</p>
<p>Zoom1</p> <p>Displays a "16:9" letterbox or "4:3" image without distortion.</p>	<p>Zoom2</p> <p>Displays a "16:9" letterbox (anamorphic) image full-screen without distortion.</p>
<p>Zoom3</p> <p>Displays a "2.35:1" letterbox (anamorphic) image full-screen without distortion. At "16:9", displays the image at its maximum (with slight enlargement).</p>	

Note

- Not available in teletext mode.
- Aspect mode can be memorized separately for SD (Standard definition), HD (High definition) signals.

Change aspect ratio

# Viewing Teletext

You can enjoy teletext broadcasting, including news, weather forecasts and subtitles, if this service is provided by the broadcasters.



## What is FLOF (FASTTEXT) mode?

In FLOF mode, four differently coloured subjects are situated at the bottom of the screen. To access more information about one of these subjects, press the appropriately coloured button. This facility enables fast access to information on the subjects shown.

## What is TOP mode? (in case of TOP text broadcasting)

TOP is a particular improvement of the standard teletext service that results in an easier search and effective guide.

- Fast overview of the teletext information available
- Easy to use step-by-step selection of the topical subject
- Page status information at the bottom of the screen

Available page up / down →  

To select among subject blocks → 

To select next subject within the subject block  
(After the last subject, it moves to the next subject block.) → 

## What is List mode?

In List mode, four differently coloured page numbers are situated at the bottom of the screen. Each of these numbers can be altered and stored in the TV's memory. ("Store frequently viewed pages", p. 17)

■ **To change mode** → "Teletext" in Setup Menu (p. 23)



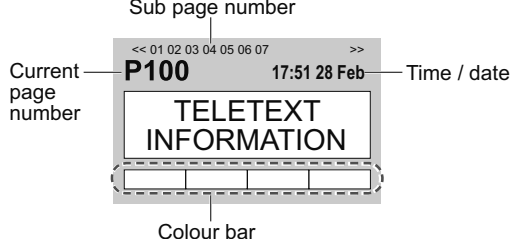

### 1 Switch to Teletext

**TEXT** ● Displays Index (content varies depending on the broadcasters)

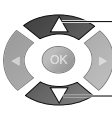

### 2 Select the page





 or  up/down  
 or  red green yellow blue  
 (Corresponds to the colour bar)







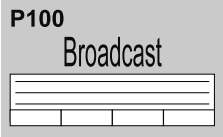
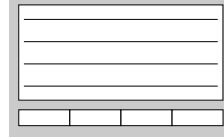
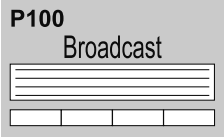











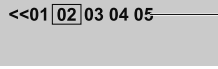

As the blue bar is displayed

■ **To adjust contrast** → **MENU** (Press three times) → 

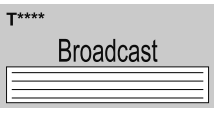
■ **To return to TV** → **TEXT** or **EXIT**

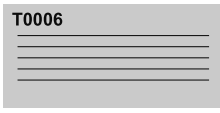
## ■ Using teletext conveniently

<b>Reveal hidden data</b>	Reveal hidden words e.g. quiz page answers <b>MENU</b> →  <b>Re-hide</b> → 
<b>FULL / TOP / BOTTOM</b>	<b>MENU</b> →  <div style="display: flex; justify-content: space-around; align-items: center; margin-top: 10px;"> <div style="text-align: center;">                       (TOP)                      (Expand the TOP half)                 </div> <div style="text-align: center;">                       (BOTTOM)                      (Expand the BOTTOM half)                 </div> <div style="text-align: center;">                       Normal (FULL)                 </div> </div>

<b>HOLD</b>	<p><b>Stop automatic updating</b> (If you wish to hold the current page without updating)</p> <p>HOLD  <b>To resume</b> → HOLD </p>
<b>INDEX</b>	<p><b>Return to the main index page</b></p> <p>INDEX </p>
<b>Call up a favourite page</b>	<p><b>View a favourite page stored</b></p> <p>F.P.  ● Call up the page stored in “blue”. ● Factory setting is “P103”.</p>
<b>View in multi window</b>	<p><b>Watch TV and Teletext in two windows at once</b></p> <p>MENU  (Press twice) →  ● Select Picture and text On or Off</p> <p>● Operations can be made only in Teletext screen.</p> 
<b>Store frequently viewed pages</b>	<p><b>Store frequently viewed pages in the colour bar</b> (List mode only)</p> <p>As page is displayed  Corresponding colour button →  press and hold</p> <p><b>To change stored pages</b></p> <p>→  Colour button you want to change → Enter new page number</p> <p> →  press and hold</p> <p><b>Example:</b> P100 Broadcast 101 200 400 888 The number changes to white.</p>
<b>View sub page</b>	<p><b>View sub page (Only when teletext is more than one page)</b></p> <p>  &lt;&lt;01 02 03 04 05 Appears at top of the screen</p> <p><b>To view specific sub page</b></p> <p>→ MENU  →  blue</p> <p> → Enter the 4-digit number example: P6</p> <p> 0 0 0 6  T0006</p> <p>● Sub pages: The number of sub pages varies depending on the broadcasters (up to 79 pages). It may take some time for searching, during which time you can watch TV.</p>
<b>Watch TV while waiting for update</b>	<p><b>View the TV picture while searching for a teletext page</b> Teletext automatically updates itself when new information becomes available. Changes to TV screen temporarily</p> <p>MENU  →  yellow →  Appears when updating is completed →  yellow → View the updated page</p> <p>(You cannot change the programme.)</p> <p>● The news page provides a function that indicates arrival of latest news (“News Flash”).</p>

# Watching Videos and DVDs

Connect the external equipment (VCRs, DVD equipment, etc.) and you can watch the input.

● To connect the equipment → p. 10 and p. 11

The Remote Control is capable of operating some functions of selected Panasonic external equipment.

**1 Turn the TV on**

- **When connecting with SCART as example 2 or 3** (p. 10 and p. 11)
  - Receives input signals automatically when playback starts
  - Input signals are automatically identified by the SCART (pin 8) terminal.
  - This function is also available for HDMI connections (p. 36).
- **If input mode is not switched automatically**
  - Perform ② and ③
  - Dependant on the setup of the equipment

**2 Display the Input select menu**

**3 Select the input mode connected to the equipment**

Input Selection

- AV1
- AV2/S
- AV3/S
- COMPONENT
- HDMI1
- HDMI2
- TV

- You can also select the input using the AV button on the remote control or the front panel of the TV. Press the button repeatedly until the desired input is selected.

**4 View**

Displays the selected mode

AV2









■ **To return to TV**

→ TV



**Note**

- If the external equipment has an aspect adjustment function, set to "16:9".
- For details, see the manual of the equipment or ask your local dealer.



Panasonic equipment connected to the TV can be directly operated with the remote control.

	<b>VCR / DVD switch*</b> Select VCR to operate Panasonic VCR or DVD equipment Select DVD to operate Panasonic DVD equipment or Player home theatre
	<b>Standby</b> Set to Standby mode / Turn on
	<b>Play</b> Playback videocassette / DVD
	<b>Stop</b> Stop the operations
	<b>Rewind / Skip / Search</b> VCR: Rewind, view the picture rapidly in reverse DVD: Skip to the previous track or title Press and hold to search backward
	<b>Fast-forward / Skip / Search</b> VCR: Fast-forward, view the picture rapidly forward DVD: Skip to the next track or title Press and hold to search forward
	<b>Pause</b> Pause / Resume DVD: Press and hold to play at slow speed
	<b>Programme Up / Down</b> Select programme
	<b>Record</b> Start recording

**\*Setting your remote control to operate Panasonic VCR, DVD, etc.**

- ① Set the VCR / DVD switch to the appropriate position → 
- ② Press and hold  during the following operations

Enter the appropriate code for the equipment to be controlled, see table below

 → Press 

“VCR” position

Equipment	Code
VCR	10 (default)
DVD	11

“DVD” position

Equipment	Code
DVD	70 (default)
Player home theatre	71

**Note**

- Confirm if the remote control works correctly after changing the code.
- The codes will be reset to default values if batteries are replaced.
- “DVD” means DVD player, DVD recorders and Recorder home theatre.
- Some operations may not be possible on some equipment models.

# How to Use Menu Functions

Various menus allow you to make settings for the picture, sound, and other functions.

**1 Display the menu**  
 ● Displays the functions that can be set (varies according to the input signal)

**2 Select the menu**  
 (example: Picture Menu)

**3 Select the item**  
 (example: Picture Menu)

**4 Adjust or select**  
 (example: Picture Menu)

**■ To return to TV at any time**  
 EXIT

**■ To return to the previous screen**  
 RETURN

**■ Choose from among alternatives**  
 Number and positions of alternatives  
 Colour Balance Normal  
 Changed

**■ Adjust using the slide bar**  
 Sharpness  
 Moved

**■ Go to the next screen**  
 Tuning Menu Access  
 Displays the next screen

**■ To reset the settings**

- To reset the picture settings only  
 ➔ "Reset to Default" in Picture Menu (p. 22)
- To reset the sound settings only  
 ➔ "Reset to Default" in Sound Menu (p. 22)
- To initialize all settings  
 ➔ "Shipping Condition" in Setup Menu (p. 29)

■ Overview

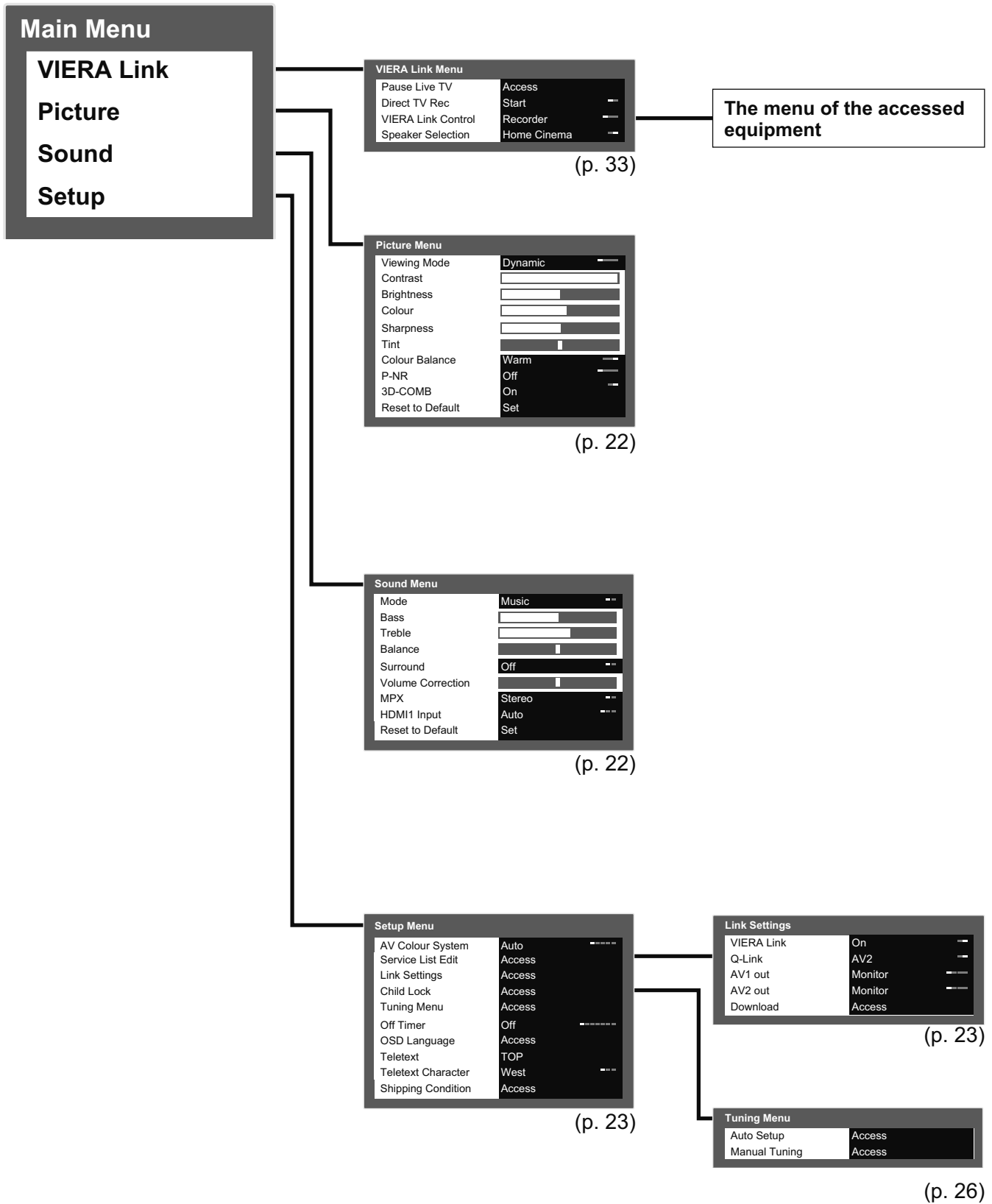

● How to Use Menu Functions  
(picture, sound quality, etc.)

Advanced

● Only available items can be selected.

# How to Use Menu Functions

## ■ Menu list

Menu	Item	Adjustments / Configurations (alternatives)
VIERA Link	Pause Live TV	Controls the connected equipment with VIERA Link function, and enables various convenient recording, playback, etc. (p. 33 - 35) ● You can also access VIERA Link Menu directly using the VIERA Link button on the remote control.
	Direct TV Rec	
	VIERA Link Control	
	Speaker Selection	
Picture	Viewing Mode	Basic picture mode ( <b>Dynamic / Normal / Cinema / Eco</b> ) Dynamic : Provides enhanced picture contrast and sharpness when viewing in a bright room Normal : Recommended for viewing under normal ambient room lighting conditions Cinema : For watching movies in a darkened room producing a cinema-like picture Eco : Adjusts picture settings automatically dependent on ambient lighting conditions ● Set for each input signal ● Changes will be stored automatically
	Contrast, Brightness, Colour, Sharpness	Increases or decreases the levels of these options according to your personal preference
	Tint	With an NTSC signal source connected to the TV, the picture hue can be adjusted to suit your taste ● For NTSC signal reception only
	Colour Balance	Allows you to set the overall colour tone of the picture ( <b>Cool / Normal / Warm</b> )
	P-NR	Picture Noise Reduction Automatically reduces unwanted picture noise and flicker noise in the contoured parts of a picture ( <b>Off / Min / Mid / Max</b> )
	3D-COMB	Occasionally, whilst viewing still or slow moving pictures, colour patterning may be seen Set to "On" to display sharper and more accurate colours ( <b>Off / On</b> ) ● For PAL or NTSC signal reception only ● Not valid on RGB, S-Video, Component and HDMI
	Reset to Default	Press the OK button to reset the present Picture Mode to the default settings
Sound	Mode	Basic sound mode ( <b>Music / Speech</b> )
	Bass	Increases or decreases level to enhance or minimise lower, deeper sound output
	Treble	Increases or decreases level to enhance or minimise sharper, higher sound output
	Balance	Adjusts volume level of right and left speakers
	Surround	Surround sound settings ( <b>Off / On</b> ) Provides a dynamic enhancer to simulate improved spatial effects ● Switching is also possible by the Surround button on the remote control (p. 9).
	Volume Correction	Adjusts volume of individual programme or input mode
	MPX	Select stereo / monaural ( <b>Mono / Stereo</b> ) ● Normally: Stereo ● Stereo signal cannot be received: Mono ● M1 / M2: Available while mono signal is transmitted
	HDMI1 Input	Select to fit the input signal ( <b>Auto / Digital / Analogue</b> ) (p. 39) Auto : Automatic detection of digital or analogue sound source Digital : HDMI cable connection Analogue : HDMI-DVI adapter cable connection ● HDMI input mode only ● HDMI2 terminal is for digital signal only ● No setting for HDMI2 available
Reset to Default	Press the OK button to reset the present Sound Mode to the default settings	

## ■ Menu list

Menu	Item	Adjustments / Configurations (alternatives)	
Setup	<b>AV Colour System</b>	Selects optional colour system based on video signals in AV mode (Auto / PAL / SECAM / M.NTSC / NTSC)	
	<b>Service List Edit</b>	Skips the unwanted programmes or edits programmes (p. 25)	
	Link Settings	<b>VIERA Link</b>	Sets to use VIERA Link functions (Off / On) (p. 32)
		<b>Q-Link</b>	Selects which AV terminal is to be used for data communication between this TV and a compatible recorder (AV1 / AV2) (p. 31) ● Select the connected terminal to the recorder even it is not compatible with Q-Link.
		<b>AV1 / AV2 out</b>	Chooses the signal to be transmitted from the TV to Q-Link (TV / AV1 / AV2 / AV3 / Monitor) ● Monitor: Image displayed on screen ● Component and HDMI signals cannot be outputted. ● No NICAM available while watching HDMI.
		<b>Download</b>	Downloads programme, language, country / region settings to a Q-Link or VIERA Link compatible equipment connected to the TV
	<b>Child Lock</b>	Locks a programme / AV input to prevent access to it (p. 28)	
	Tuning Menu	<b>Auto Setup</b>	Automatically sets the programmes received in the area (p. 27)
		<b>Manual Tuning</b>	Sets the programmes manually (p. 27)
	<b>Off Timer</b>	Sets the time the TV automatically turns Off (Off / 15 / 30 / 45 / 60 / 75 / 90 minutes)	
	<b>OSD Language</b>	Changes language for on-screen displays	
	<b>Teletext</b>	Teletext display mode (TOP (FLOF) / List) (p. 16)	
	<b>Teletext Character</b>	Selects teletext language (West / East1 / East2) ● West: English, French, German, Greek, Italian, Spanish, Swedish, Turkish, etc. ● East1: Czech, English, Estonian, Lettish, Rumanian, Russian, Ukrainian, etc. ● East2: Czech, Hungarian, Lettish, Polish, Rumanian, etc.	
	<b>Shipping Condition</b>	Resets all settings, for example, when moving house (p. 29)	

● Only available items can be selected.

● How to Use Menu Functions  
(picture, sound quality, etc.)

Advanced

# Editing Programmes

You can skip unwanted programmes or edit programmes.

**1 Display the menu**

MENU

**2 Select "Setup"**

Main Menu

VIERA Link
Picture
Sound
<b>Setup</b>

② access

① select

**3 Select "Service List Edit"**

Setup Menu

Service List Edit	Access
Link Settings	
Child Lock	
Tuning Menu	
Off Timer	Off
OSD Language	
Teletext	TOP
Teletext Character	West
Shipping Condition	

② access

① select

■ To return to TV

EXIT

**4 Set** \_\_\_\_\_

Skip unwanted programmes

Edit programmes (Change name, Move)

Service List Edit

You can hide unwanted services. The deleted services cannot be displayed except in this function. Use this function to skip unwanted programmes.

### Select a service and add / delete

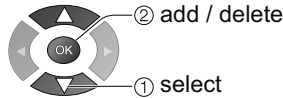

- :add
- :delete (skip)

- To retune each programme (Manual Tuning) → (p. 27)

You can change the programme name and programme position.

- If a VCR is connected only with the RF cable, edit "VCR".

### ① Select the programme to edit



Programme position

Name



### ② Edit

#### ■ To change the name displayed when selecting programmes

Select "Rename"



Set characters

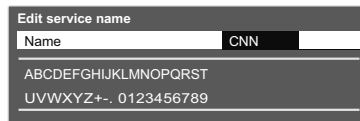
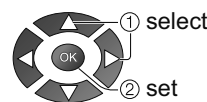

(maximum: five characters)



Store



#### ■ To move the programme position

Select new position



Store



# Tuning Programmes

You can retune all the TV programmes when moving house or search for new services which may have recently started broadcasting.

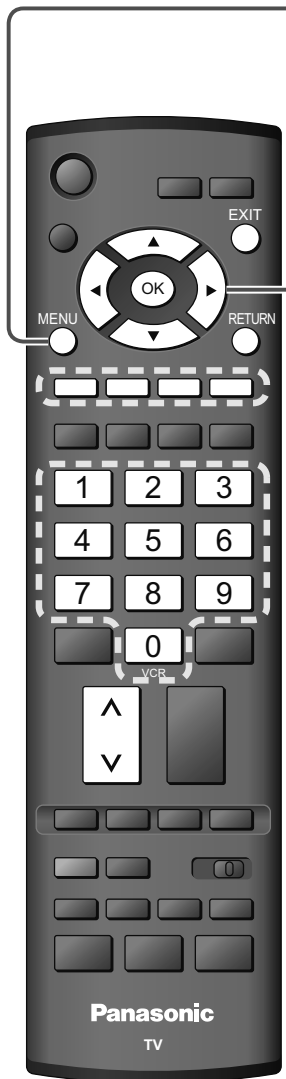

**1 Display the menu**

MENU

**2 Select "Setup"**

Main Menu	
VIERA Link	
Picture	
Sound	
Setup	

**3 Select "Tuning Menu"**

Setup Menu	
Service List Edit	
Link Settings	
Child Lock	
Tuning Menu	Access
Off Timer	Off
OSD Language	
Teletext	TOP
Teletext Character	West
Shipping Condition	

**4 Select a function**

Tuning Menu	
Auto Setup	Access
Manual Tuning	Access

**5 Set** \_\_\_\_\_

■ To return to TV  
EXIT

Set all programmes automatically

**Auto Setup**

Automatically retune all programmes received in the area.  
 ● If a Child Lock PIN number (p. 28) has been set, it must be entered.

**Start Auto Setup**

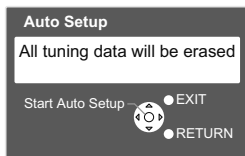

**Settings are made automatically**

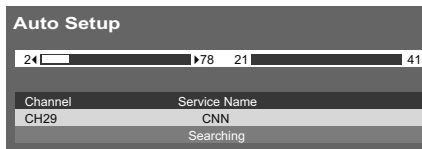

- All the previous tuning settings are erased.
- The programme, language, country / region settings are downloaded to a Q-Link or VIERA Link compatible equipment connected to the TV.
- When the operation is completed, the programme at programme position "1" will be displayed.
- If tuning has not been done completely → "Manual Tuning"

■ **For Auto Setup, using the buttons on the side of the TV (p. 8)**

- ① Press repeatedly until "Auto Setup" appears



- ② Access "Auto Setup"



- ③ Start "Auto Setup"



- To return to TV → 

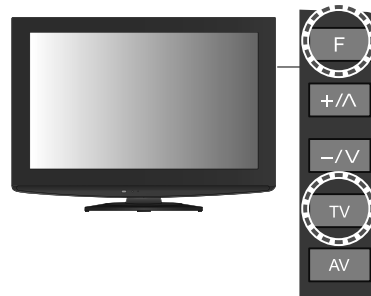

Set programme manually

**Manual Tuning**

■ **Fine Tuning**

Use to make small adjustments to the tuning of an individual programme (affected by weather conditions, etc.)

■ **Manual Tuning**

Set programme manually after Auto Setup.

- Set Sound System and Colour System, and then perform this function. Normally set Colour System "Auto".
- If a VCR is connected only with the RF cable, select programme position "0".

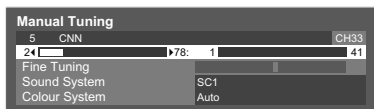

SC1: PAL B, G, H / SECAM B, G  
 SC2: PAL I  
 SC3: PAL D, K / SECAM D, K  
 F: SECAM L / L'

Select the programme position



Select the programme



Search and store

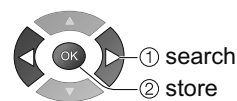

# Control Programme Audience

You can lock specific programmes / AV input terminals and control who watches them. (When the locked programme / input is selected, a message appears; by entering the PIN number, you can watch it.)

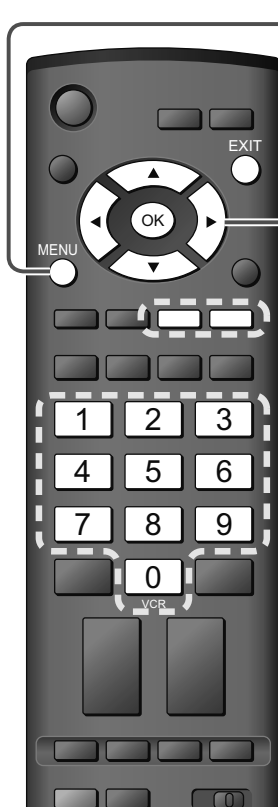

**1 Display the menu**  
MENU

**2 Select "Setup"**  
Main Menu  
VIERA Link  
Picture  
Sound  
Setup

**3 Select "Child Lock"**  
Setup Menu  
Service List Edit  
Link Settings  
Child Lock Access  
Tuning Menu  
Off Timer Off  
OSD Language  
Teletext TOP  
Teletext Character West  
Shipping Condition

**4 Set**

EXIT

**Control programme audience**

**Child Lock**

**1 Enter the PIN number (4 digits)**

Child Lock-PIN Entry  
Please enter new PIN  
PIN

1 2 3  
4 5 6  
7 8 9  
0

- Enter the PIN number twice at first setting.
- Make a note of the PIN number in case you forget it.

**2 Select "Child Lock List"**

Child Lock  
Change PIN  
Child Lock List Access

2 access  
1 select

**3 Select the programme / input to be locked**

Child Lock List - Services and AV  
VCR  
1 BBC1  
2 \*\*\*\*\*  
3 \*\*\*\*\*  
4  
5  
AV1  
AV2

2 set  
1 select

- To cancel  
➔ Select the locked programme / input  
➔ OK
- To lock all ➔ yellow
- To cancel all locks ➔ blue

Appears when the programme / input is locked

**To change the PIN number**  
Select "Change PIN" in 2 and enter a new PIN number twice.

**Note**

- Setting "Shipping Condition" (p. 29) erases the PIN number and all settings.

# Restore Settings

Resets the TV to its original condition, i.e. no programmes tuned in. All settings (programmes, picture, sound quality, etc.) are reset.

**1 Display the menu**  
 MENU

**2 Select "Setup"**  
 Main Menu  
 VIERA Link  
 Picture  
 Sound  
**Setup**

**3 Select "Shipping Condition"**  
 Setup Menu  
 Service List Edit  
 Link Settings  
 Child Lock  
 Tuning Menu  
 Off Timer Off  
 OSD Language  
 Teletext TOP  
 Teletext Character West  
**Shipping Condition Access**

**4 Set**

■ To return to TV  
 EXIT

Advanced

Restore Settings

**Shipping Condition**

**① Check the message and initialise**

**Shipping Condition**

All tuning data will be erased  
Are you sure?  
Are you sure?

Confirm → ● EXIT  
● RETURN

**② Follow the on-screen instructions**

- "Auto Setup" will automatically start when Mains power On / Off switch is next turned On. (p. 12)

■ To retune TV programmes only, e.g. after moving house

- ➔ "Auto Setup" (p. 27)

# Link Functions (Q-Link VIERA Link)

Q-Link connects the TV and DVD Recorder / VCR, and enables easy recording, playback, etc. (p. 31)  
 VIERA Link (HDMI Control™) connects the TV and the equipment with VIERA Link function, and enables easy control, convenient recording, playback, etc. (p. 32 - 34)  
 You can use Q-Link and VIERA Link functions together.

## Summary of Q-Link and VIERA Link functions

Features	Connection	Q-Link (SCART connection)	VIERA Link (HDMI connection only)	VIERA Link (SCART and HDMI connection)
Preset download		○	○**	○
Easy playback		○	○	○
Speaker control		-	○	○
Control the menu of the connected equipment by VIERA remote control		-	○*	○*
Direct TV Recording		○	-	○**
Pause Live TV programme		-	-	○**

\* : Available with the equipment which has "HDMI Control 2" or "HDMI Control 3" function.  
 \*\* : Available with the equipment which has "HDMI Control 3" function.

## Connections

Read the manual of the equipment, too.

### Q-Link

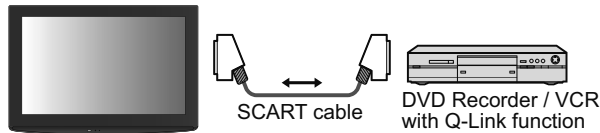

- Connect the DVD Recorder / VCR supporting Q-Link to the TV's AV1 or AV2 terminal via a fully wired SCART cable.

### VIERA Link

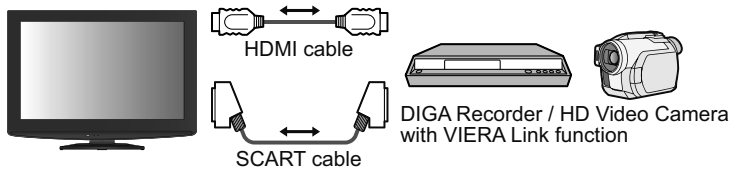

- Connect the equipment supporting VIERA Link to the TV's AV1, AV2, HDMI1 or HDMI2 terminals via fully wired SCART and HDMI cables together.
- Some functions are available only with HDMI cable connection. But use both HDMI and SCART cables to support many features normally.

- SCART cable  
Use fully wired SCART cable.
- HDMI cable  
Use fully wired HDMI compliant cable. Non-HDMI-compliant cables cannot be utilized.  
Recommended Panasonic's HDMI cable part number:  
 • RP-CDHG10 (1.0 m)  
 • RP-CDHG15 (1.5 m)  
 • RP-CDHG20 (2.0 m)  
 • RP-CDHG30 (3.0 m)  
 • RP-CDHG50 (5.0 m)

### For Speaker control (Home Cinema)

- To use Amplifier

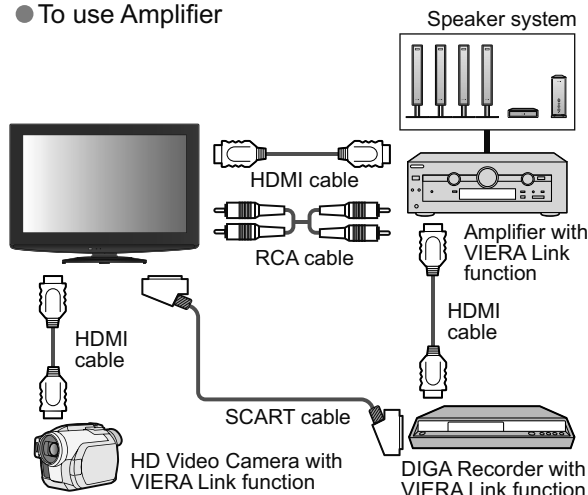

- To use Player theatre / Blu-ray Disc theatre

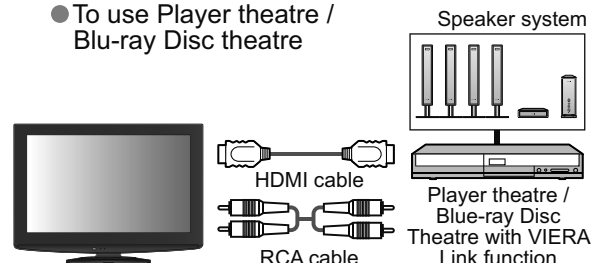

## Q-Link

### ■ Preparations

- Connect the DVD Recorder / VCR with the following logos: "Q-Link", "NEXTVIEWLINK", "DATA LOGIC", "Easy Link", "Megalogic" or "SMARTLINK"
- Q-Link connection → p. 30
- Set up the DVD Recorder / VCR. Read the manual of the equipment.
- Q-Link terminal setup in Setup Menu → "Q-Link" (p. 23), "AV1 / AV2 out" (p. 23)
- Download preset - programme, language, country / region setting (Preset download) → "Download" (p. 23) or "Auto Setup" (p. 27) or "Auto Setup" - when first using the TV (p. 12)

### ■ Features available

Some recorders are not applicable. Read the manual of the recorder.

Recording the current programme in DVD Recorder / VCR immediately.

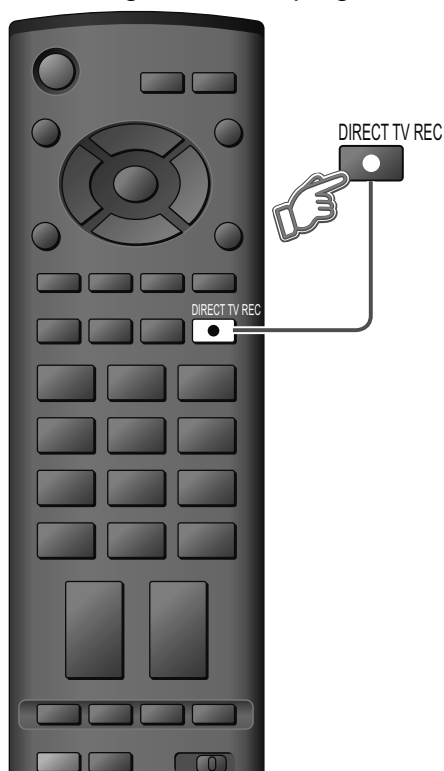

#### ● Available conditions:

Current mode	Using tuner	How to record
TV	TV	TV monitor out
	Recorder	Recorder's tuner
AV (watching recorder's tuner)	Recorder	Recorder's tuner
AV (watching recorder's external input)	—	Recorder's external input
AV (watching TV's external input)	—	TV monitor out

- When Direct TV Recording is performed, the recorder is automatically turned on if it is in Standby mode.
- Changing programme or turning off the TV is available while the recorder is recording from its own tuner.
- Changing programme is not available while the recorder is recording from the TV tuner.
- Turning off the TV will stop the recording if the recording from an AV source connected to the TV.

**Direct TV Recording -**  
What you see is What you record

**Information / Message**

Recording information or if recording is not possible, a message is displayed.

- "DATA LOGIC" (a trademark of Metz Corporation)
- "Easy Link" (a trademark of Philips Corporation)

- "Megalogic" (a trademark of Grundig Corporation)
- "SMARTLINK" (a trademark of Sony Corporation)

● Link Functions  
(Q-Link / VIERA Link)

Advanced

# Link Functions (Q-Link VIERA Link)

## VIERA Link “HDAVI Control™”\*

\*Enjoy additional HDMI Inter-Operability with Panasonic products which have “HDAVI Control” function. This TV supports “HDAVI Control 3” function.

Connections to the equipment (DIGA Recorder, HD Video Camera, Player theatre, Amplifier, etc.) with HDMI and SCART cables allow you to interface them automatically.

These features are limited to models incorporating “HDAVI Control” and “VIERA Link”.

- Some functions are not available depending on the equipment’s version of HDAVI Control. Please confirm the connected equipment’s version of HDAVI Control.
- VIERA Link “HDAVI Control”, based on the control functions provided by HDMI which is an industry standard known as HDMI CEC (Consumer Electronics Control), is a unique function that we have developed and added. As such, its operation with other manufacturers’ equipment that supports HDMI CEC cannot be guaranteed.

Please refer to individual manuals for other manufacturers’ equipment supporting VIERA Link function. About applicable Panasonic equipment, consult your local Panasonic dealer.

### ■ Preparations

- Connect the equipment supporting VIERA Link.
- VIERA Link connection → p. 30
- Set up the connected equipment. Read the manual of the equipment.
- For optimal recording, the settings of the recorder might be required. For details, read the manual of the recorder.
- Download preset - programme, language, country / region setting (Preset download)  
→ “Download” (p. 23) or “Auto Setup” (p. 27) or “Auto Setup” - when first using the TV (p. 12)
- Set VIERA Link On in Setup Menu → “VIERA Link” (p. 23)
- Set up the TV  
→ **After connection, turn the equipment on and then switch the TV on.**  
**Select the input mode to HDMI1 or HDMI2 (p. 18), and make sure that an image is displayed correctly.**  
This setup should be done each time when the following conditions occur:
  - for the first time
  - when adding or reconnecting equipment
  - when changing setup

### ■ Features available

#### Easy playback

Automatic Input switching - When the connected equipment is operated, input mode is switched automatically. When it is stopped operating, input mode is returned.

■ Features available (Using VIERA Link Menu)

Pause Live TV programme  
(HDAVI Control 3 and Recorder with HDD)  
Pause Live TV

You can pause the live TV programme and resume later.

- This function is available with DIGA Recorder which has HDD and “HDAVI Control 3” function.
- Connect DIGA Recorder with both HDMI and SCART cables to use this function.
- If you cannot operate, check the settings and the equipment → “Preparations” (p. 32)

Access and pause the live TV programme



① Display “VIERA Link Menu”



② Select “Pause Live TV” and pause

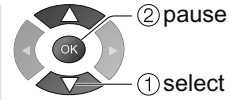
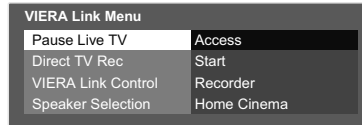

- Live TV programme is recorded on HDD from where it was paused.
- If the paused TV picture disappears after a few minutes → OPTION (the paused picture will be restored)

■ To resume (stop pause)

Select “Pause Live TV” and access

- About the operations after resuming, read the manual of the equipment.

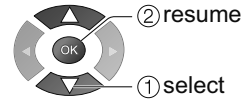

■ To return to Live TV

(cancel pause or resumed playback)

→ TV (change the input mode)

- If you cancel pause or resumed playback, the recorded programme will be deleted from HDD.

Recording the current programme in DIGA Recorder immediately.

- This function is available with DIGA Recorder which has “HDAVI Control 3” function.
- Connect DIGA Recorder with both HDMI and SCART cables to use this function.
- If you cannot operate, check the settings and the equipment → “Preparations” (p. 32)
- Changing programme or turning off the TV is available while the recorder is recording from its own tuner.
- Changing programme is not available while the recorder is recording from the TV tuner.
- Turning off the TV will stop the recording if the recording from an AV source connected to the TV.

Direct TV Recording -  
What you see is What you record  
(HDAVI Control 3)

Direct TV Rec



① Display “VIERA Link Menu”



② Select “Direct TV Rec” and start recording

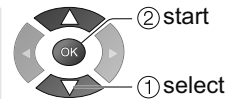
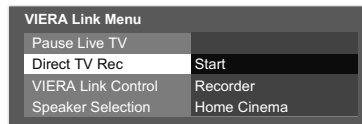

- You can also start recording directly → DIRECT TV REC

■ To stop recording

Select “Stop” in “Direct TV Rec” and access

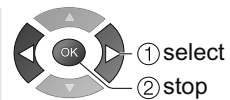
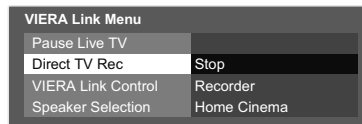

# Link Functions (Q-Link VIERA Link)

## ■ Features available (Using VIERA Link Menu)

You can control some functions of the connected equipment with this TV remote control (point the remote control at the TV's signal receiver).

- This function is available with the equipment which has "HDAVI Control 2" or "HDAVI Control 3" function.
- If you cannot operate, check the settings and the equipment → "Preparations" (p. 32)

### Access and operate the menu of the equipment



① Display "VIERA Link Menu"



② Select "VIERA Link Control"



③ Select the equipment you want to access

- "Home Cinema" means Player theatre, Recorder theatre and Amplifier.

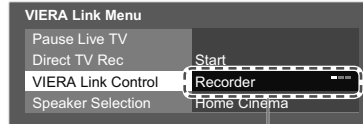

**Recorder / Player / Home Cinema / Video Camera**

The type of the connected equipment is displayed.  
Select the type of the equipment and access.

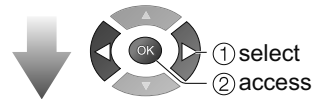

**The menu of the accessed equipment**  
(Input mode will be changed automatically)

④ Operate the menu of the equipment

- Available VIERA remote control buttons (depending on the connected equipment):

	Move the cursor / select the menu
	Move the cursor / access / adjust
	Store / set / access
	Return to the previous menu
	Exit the menu
	Display the operation guide for the equipment / The same functions with the OPTION button of the equipment
	Access when the key words are displayed on colour bar

- About the operations for the equipment, read the manual of the equipment.

Control the menu of the connected equipment by VIERA remote control

(HDAVI Control 2)  
(HDAVI Control 3)

**VIERA Link Control**

### ■ If you access the invalid equipment

#### When the equipment with "HDAVI Control" function is connected

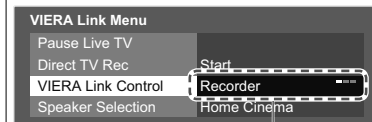

**Recorder / Player / Home Cinema / Video Camera**

The type of the connected equipment is displayed.  
But you cannot access it. Use its own remote control to operate the equipment.

#### When the equipment of other types or manufacturers is connected

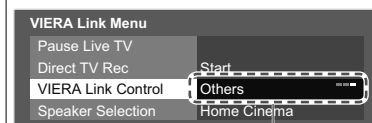

**Others**

"Others" is displayed.  
You cannot access it. Use its own remote control to operate the equipment.

■ Features available (Using VIERA Link Menu)

You can control the theatre speaker with this TV remote control (point the remote control at the TV's signal receiver).

- This function is available with the Amplifier or Player theatre which has "HDAVI Control" function.
- If you cannot operate, check the settings and the equipment → "Preparations" (p. 32)

**Access and control the speaker volume**

Speaker control

Speaker Selection

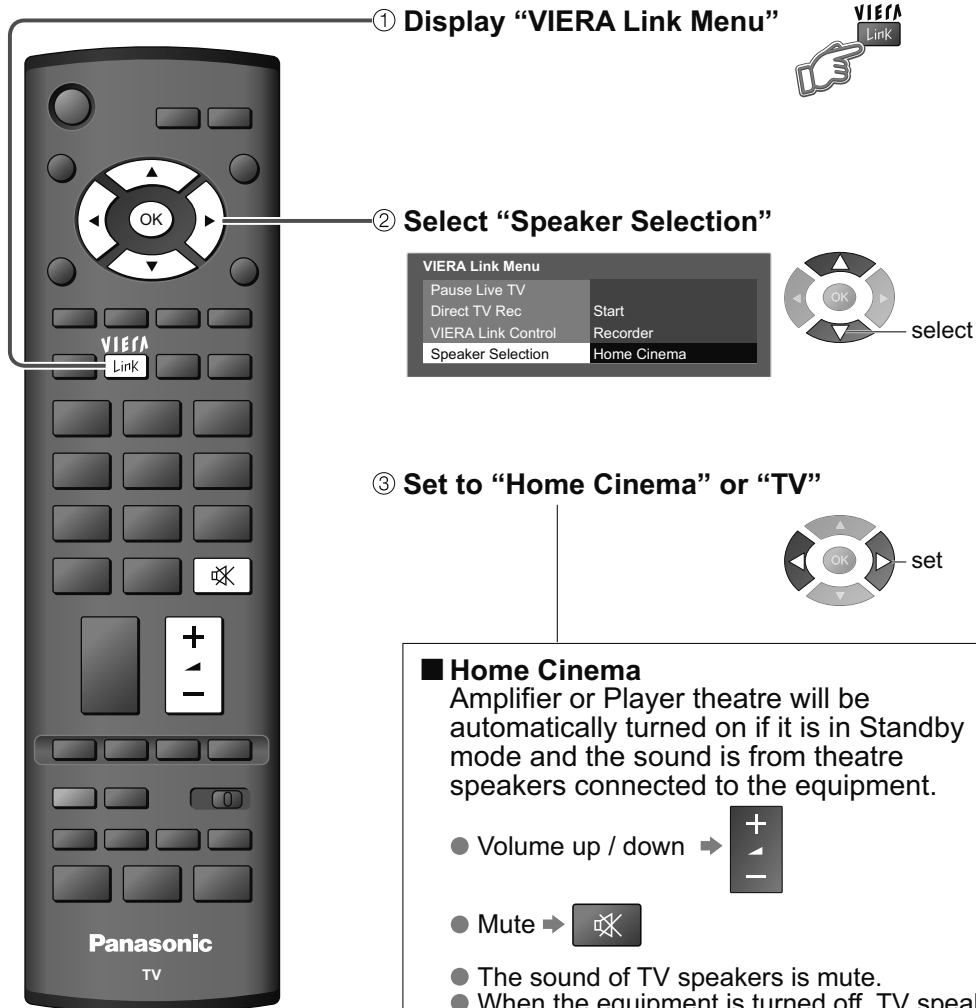

■ Home Cinema

Amplifier or Player theatre will be automatically turned on if it is in Standby mode and the sound is from theatre speakers connected to the equipment.

- Volume up / down →
- Mute →
- The sound of TV speakers is mute.
- When the equipment is turned off, TV speakers will be active.

■ TV

TV speakers are active.

**Note**

- This function may not work properly depending on the connected equipment.
- Image or sound may not be available for the first few seconds when the playback starts.
- Image or sound may not be available for the first few seconds when Input mode is switched.
- Volume function will be displayed when adjusting the volume of the equipment.
- Easy playback is also available by using the remote control for Amplifier or Player theatre. Read the manual of the equipment.
- About HDMI cable for connecting Panasonic HD Video Camera, read the manual of the equipment.
- If more than one equipment of the same type are connected to the TV by HDMI cables, for example two DIGA Recorders to HDMI1 and HDMI2, VIERA Link will only be available for the lower terminal number, in this case HDMI1.

# External Equipment

These diagrams show our recommendations for how to connect the TV to your various equipment. For other connections, consult the instructions for each piece of equipment, the table below, and the specifications (p. 43).

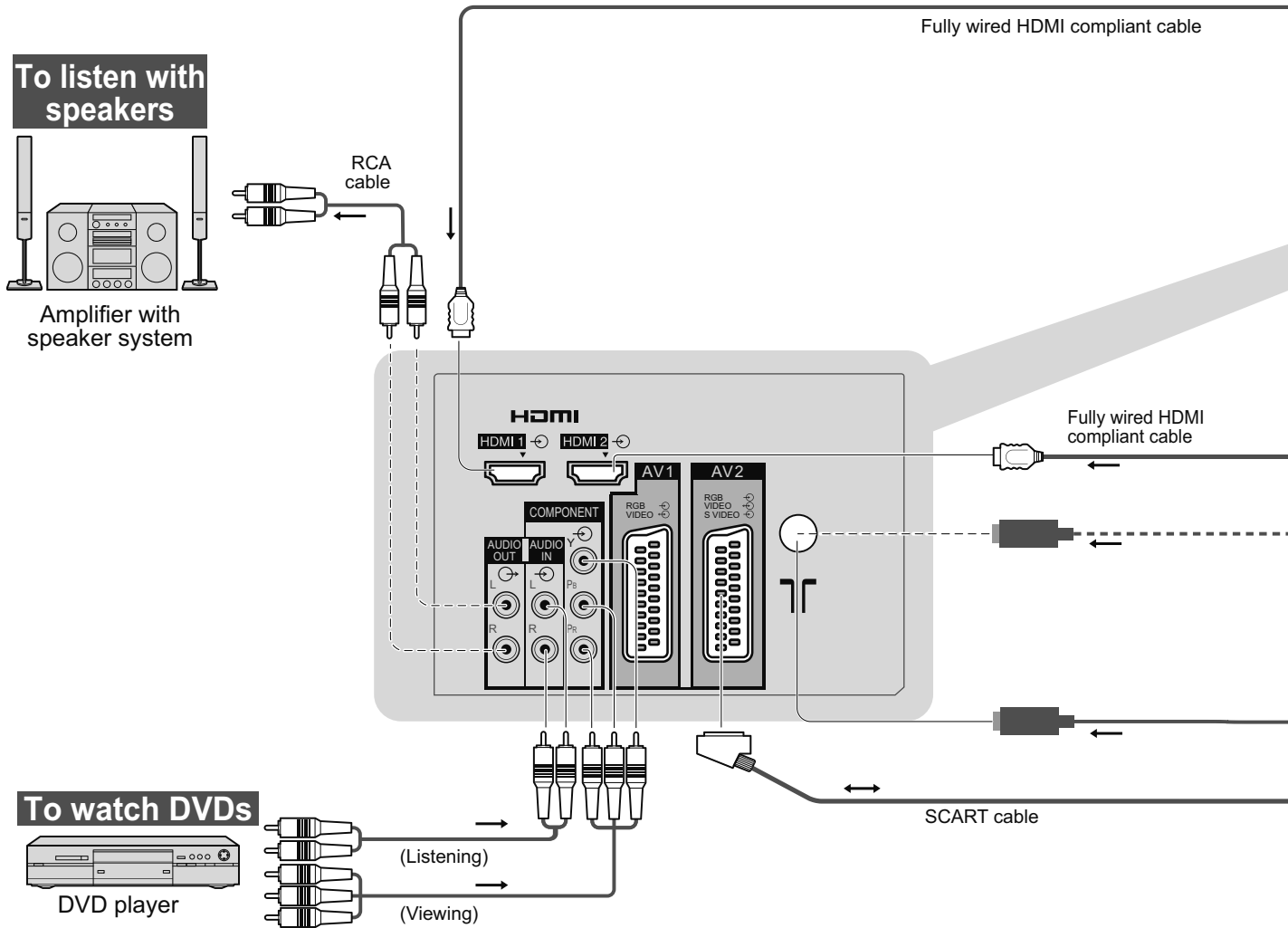

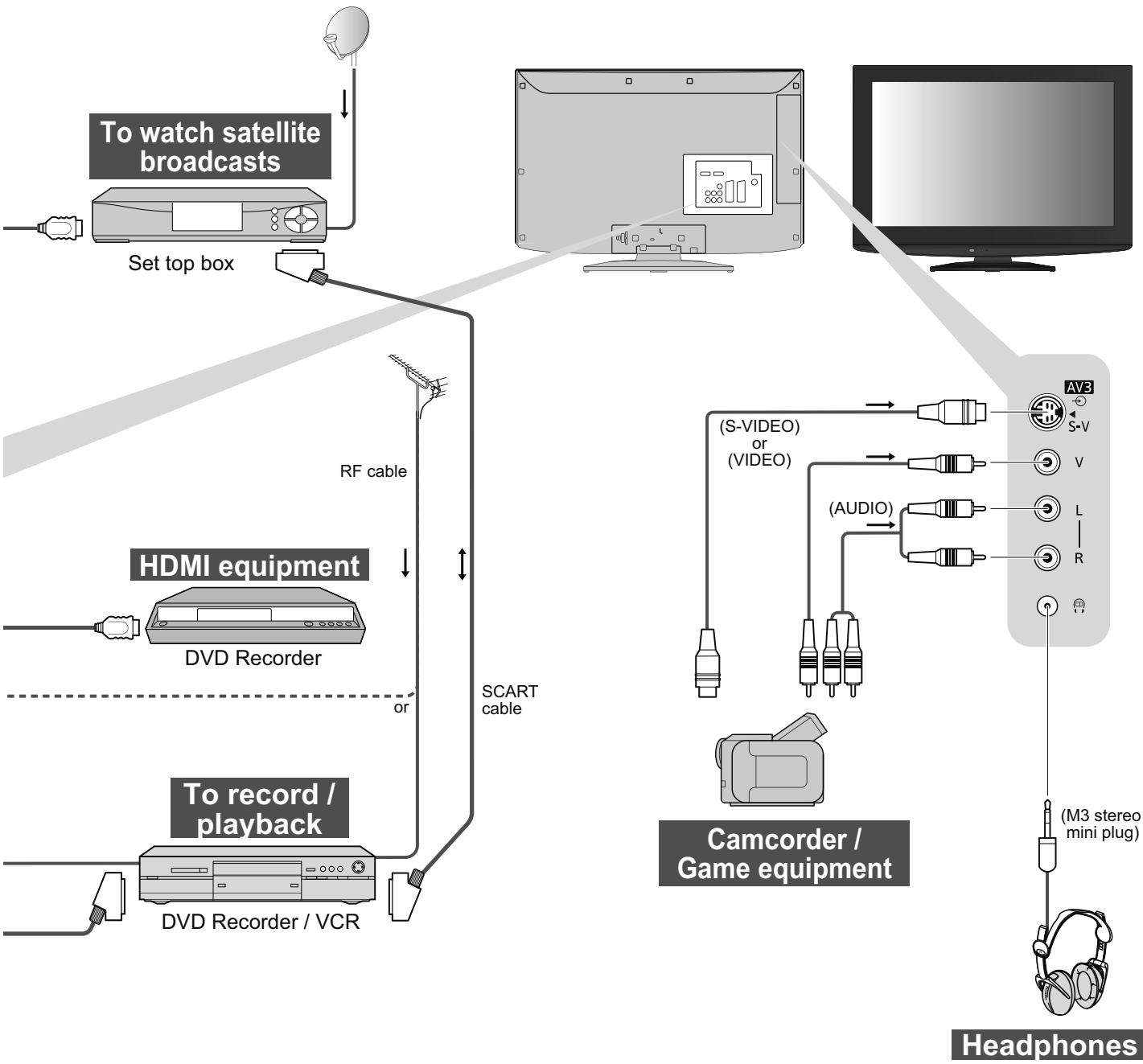

## Types of connectable equipment to each terminal

Terminal	AV1	AV2	AV3 (Side of TV)
Recording / Playback (equipment)			
To record / playback videocassettes / DVDs (VCR / DVD recorder)	<input type="checkbox"/>	<input type="checkbox"/>	
To watch DVDs (DVD player)	<input type="checkbox"/>	<input type="checkbox"/>	<input type="checkbox"/>
To watch camcorder images (Video camera)	<input type="checkbox"/>	<input type="checkbox"/>	<input type="checkbox"/>
To watch satellite broadcasts (Set top box)	<input type="checkbox"/>	<input type="checkbox"/>	<input type="checkbox"/>
To play games (Game equipment)	<input type="checkbox"/>	<input type="checkbox"/>	<input type="checkbox"/>
To use amplifier with speaker system			
Q-Link	<input type="checkbox"/>	<input type="checkbox"/>	
VIERA Link	<input type="checkbox"/> (with HDMI)	<input type="checkbox"/> (with HDMI)	
Direct TV Recording	<input type="checkbox"/>	<input type="checkbox"/>	



External Equipment

Advanced

COMPONENT 	AUDIO OUT 	HDMI 	
		1	2
<input type="radio"/>		<input type="radio"/>	<input type="radio"/>
		<input type="radio"/>	<input type="radio"/>
		<input type="radio"/>	<input type="radio"/>
	<input type="radio"/>		
		<input type="radio"/>	<input type="radio"/>
		<input type="radio"/>	<input type="radio"/>

○: Recommended Connection

# Technical Information

## Auto Aspect

The optimum size and aspect can be chosen, and you can enjoy finer images. (p. 15)

### ■ Auto

Auto aspect determines the best aspect ratio to use to fill your screen. It does this using a four step process to determine if the picture being viewed is a widescreen picture.

If Auto aspect detects a widescreen signal it switches into the appropriate 16:9 or 14:9 widescreen mode. If Auto aspect does not detect a widescreen signal then this advanced TV enhances the picture for optimum viewing pleasure.

The text shown on the screen indicates how Auto aspect determined which ratio to use:

“WIDE” appears in the top left of the screen if a widescreen identification signal (WSS) is found or a signal found through a SCART or HDMI terminal. Auto aspect switches to the appropriate 16:9 or 14:9 widescreen ratio. This function will also work in any aspect mode. “Auto” appears in the top left of the screen if black stripes above and below the picture are detected. Auto aspect chooses the best ratio and expands the picture to fill the screen.

This process can take several minutes, depending on the darkness of the picture.

Signal name		Aspect Control Signal								
		Widescreen signal (WSS)				Control signal through SCART (pin 8) or HDMI terminal				
		TV	AV1	AV2	AV3	COMPONENT	AV1	AV2	HDMI1	HDMI2
PAL		○	○	○	○	/	○	○	/	
PAL 525/60		-	-	-	-		○	○		
M.NTSC		-	-	-	-		○	○		
NTSC (AV input only)		-	-	-	-		○	○		
SD	525(480)/60i	/				-	/		○	○
	525(480)/60p					-			○	○
	625(576)/50i					○			○	○
	625(576)/50p					○			○	○
HD	750(720)/50p	/				-	/		○	○
	750(720)/60p					-			○	○
	1125(1080)/50i					-			○	○
	1125(1080)/60i					-			○	○

### Note

- The ratio varies depending on the programme, etc. If the ratio is greater than the standard “16:9”, black bands may appear at the top and bottom of the screen.
- If the screen size looks unusual when a widescreen-recorded programme is played back on a VCR, adjust the tracking of the VCR. (See the VCR manual.)

## HDMI connection

HDMI (high-definition multimedia interface) allows you to enjoy high-definition digital images and high-quality sound by connecting the TV and the equipment.

HDMI-compatible equipment (\*1) with an HDMI or DVI output terminal, such as a set top box or a DVD player, can be connected to the HDMI terminal using an HDMI compliant (fully wired) cable.

About connections, see “External Equipment” (p. 36).

### Note

- HDMI is the world’s first complete digital consumer AV interface complying with a non-compression standard.
- If the external equipment has only a DVI output, connect to the HDMI1 terminal via a DVI to HDMI adapter cable (\*2).
- When the DVI to HDMI adapter cable is used, connect the audio cable to the audio input terminal (HDMI1: use COMPONENT-AUDIO terminals).
- Audio settings can be made on the “HDMI1 Input” menu screen. (p. 22)
- Applicable audio signal sampling frequencies (2ch L.PCM): 48 kHz, 44.1 kHz, 32 kHz
- HDMI2 terminal is for digital audio signal only.
- Use with a PC is not assumed.
- If the connected equipment has an aspect adjustment function, set the aspect ratio to “16:9”.
- These HDMI connectors are “type A”.
- These HDMI connectors are compatible with HDCP (High-Bandwidth Digital Content Protection) copyright protection.
- An equipment having no digital output terminal may be connected to the input terminal of either “COMPONENT”, “S-VIDEO”, or “VIDEO” to receive analogue signals.
- The HDMI input terminal can be used with only the following image signals:  
480i, 480p, 576i, 576p, 720p and 1080i. Match the output setting of the digital equipment.
- For details of the applicable HDMI signals, see p. 40.

(\*1): The HDMI logo is displayed on HDMI-compliant equipment.

(\*2): Enquire at your local digital equipment retailer shop.

## SCART, S-VIDEO and HDMI terminal information

### AV1 SCART terminal (RGB, VIDEO, Q-Link)

Suitable inputs for AV1 include RGB (Red / Green / Blue).

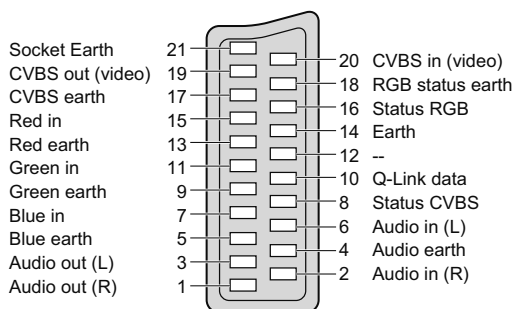

### AV2 SCART terminal (RGB, VIDEO, S-VIDEO, Q-Link)

AV2 - Pins 15 and 20 are dependent on AV2 S-VHS / VIDEO switching.

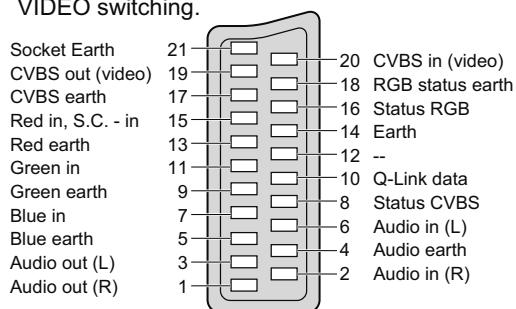

### AV3 S-VIDEO 4 pin terminal

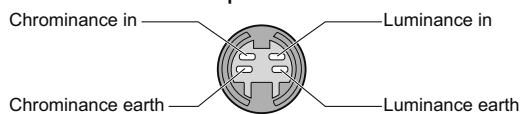

### HDMI terminal

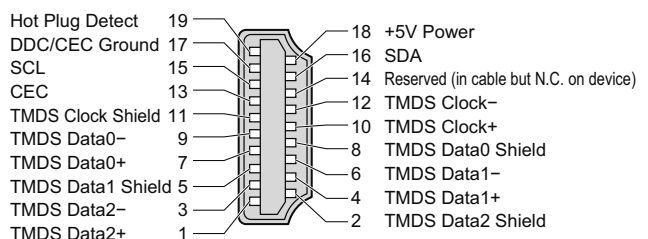

# Technical Information

## Input signal that can be displayed

### COMPONENT (Y, P<sub>B</sub>, P<sub>R</sub>), HDMI

\* Mark: Applicable input signal

Signal name	COMPONENT	HDMI
525 (480) / 60i	*	*
525 (480) / 60p	*	*
625 (576) / 50i	*	*
625 (576) / 50p	*	*
750 (720) / 60p	*	*
750 (720) / 50p	*	*
1,125 (1,080) / 60i	*	*
1,125 (1,080) / 50i	*	*

#### Note

- Signals other than above may not be displayed properly.
- The above signals are reformatted for optimal viewing on your display.

# FAQs

Before requesting service or assistance, please follow these simple guides to resolve the problem. If the problem still persists, please contact your local Panasonic dealer for assistance.

## White spots or shadow images (noise)

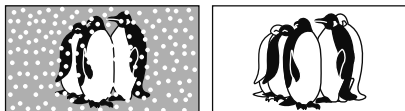

- Check the position, direction, and connection of the aerial.

## Neither image nor sound is produced

- Is the TV in "AV mode"?
- Is the mains lead plugged into the socket outlet?
- Is the TV turned On?
- Check Picture Menu (p. 22) and volume.
- Check all required SCART cables and connections are firmly in place.

## Auto aspect

- Auto aspect is designed to provide you with the best aspect ratio to use to fill your screen. For user control please see p. 38.

## S-Video / black and white picture

- Using AV button please confirm your selection is S-Video i.e. AV2/S (p. 18).

## On Screen messages - i.e. EC/AV1

- You can simply clear these →  Press again to redisplay.

## An error message appears

- Follow the message's instructions.
- If the problem persists, contact the authorized Service Centre.

## Q-Link function does not work

- Please confirm SCART cable, connection and Q-Link settings. Also please set "AV1 / AV2 out" in the Setup Menu (p. 23).

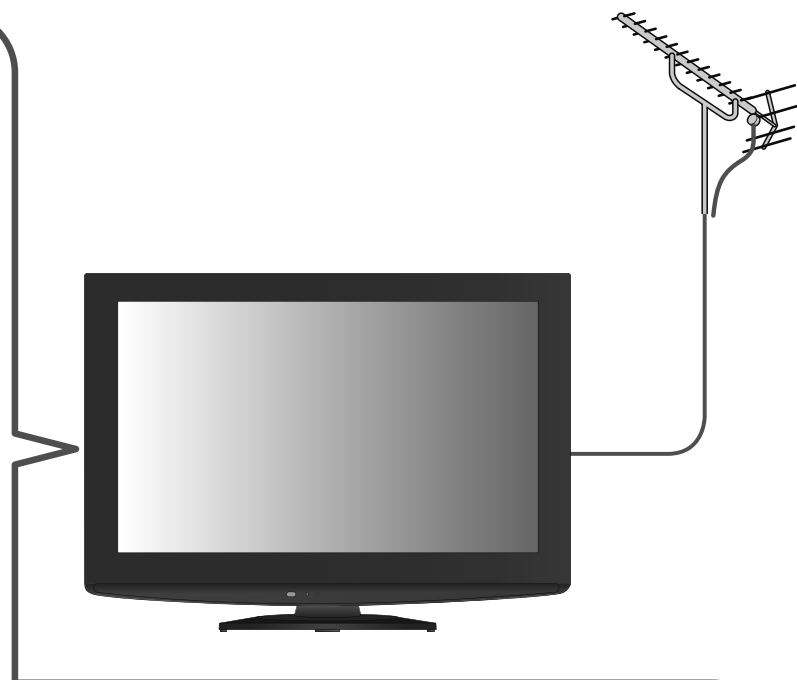

## "VIERA Link" function does not work and an error message appears

- Confirm the connection.
- Turn the connected equipment on and then switch the TV on. (p. 32)

## Recording does not start immediately

- Check the settings of the recorder. For details, read the manual of the recorder.

## There may be red spots, blue spots, green spots and black spots on the screen

- This is a characteristic of liquid crystal panels and is not a problem. The liquid crystal panel is built with very high precision technology giving you fine picture details. Occasionally, a few non-active pixels may appear on the screen as a fixed point of red, green, blue or black. Please note this does not affect the performance of your LCD.

## The LCD panel moves slightly when it is pushed with a finger Clattered sound might be heard

- There are some looseness around the panel to prevent the damage to the panel. The panel might move slightly when it is pushed with a finger, and clattered sound might be heard. This is not a malfunction.

# FAQs

	Problem	Actions
Screen	Chaotic image, noisy	<ul style="list-style-type: none"> <li>● Set "P-NR" in the Picture Menu (to remove noise). (p. 22)</li> <li>● Check nearby electrical products (car, motorcycle, fluorescent lamp).</li> </ul>
	No image can be displayed	<ul style="list-style-type: none"> <li>● Is "Colour" or "Contrast" in the Picture Menu set to the minimum? (p. 22)</li> <li>● Check Colour System. (p. 27)</li> </ul>
	Blurry or distorted image (no sound or low volume)	<ul style="list-style-type: none"> <li>● Reset programme. (p. 25)</li> </ul>
	Unusual image is displayed	<ul style="list-style-type: none"> <li>● Turn off the TV with Mains power On / Off switch, then turn it On again.</li> </ul>
Sound	No sound is produced	<ul style="list-style-type: none"> <li>● Is "Sound mute" active? (p. 9)</li> <li>● Is the volume set to the minimum?</li> </ul>
	Sound level is low or sound is distorted	<ul style="list-style-type: none"> <li>● Sound signal reception may be deteriorated.</li> <li>● Set "MPX" (p. 22) in the Sound Menu to "Mono".</li> </ul>
HDMI	Sound is unusual	<ul style="list-style-type: none"> <li>● Set the sound setting of the connected equipment to "2ch L.PCM".</li> <li>● Check the "HDMI1 Input" setting in the Sound Menu. (p. 22)</li> <li>● If digital sound connection has a problem, select analogue sound connection. (p. 39)</li> </ul>
	Pictures from external equipment are unusual when the equipment is connected via HDMI	<ul style="list-style-type: none"> <li>● Is the HDMI cable connected properly? (p. 36)</li> <li>● Turn Off the TV and equipment, then turn them On again.</li> <li>● Check an input signal from the equipment. (p. 41)</li> <li>● Use an equipment compliant with EIA/CEA-861/861B.</li> </ul>
Other	TV goes into "Standby mode"	<ul style="list-style-type: none"> <li>● Off Timer function is activated.</li> <li>● The TV enters "Standby mode" about 30 mins. after analogue broadcasting ends.</li> </ul>
	The remote control does not work	<ul style="list-style-type: none"> <li>● Are the batteries installed correctly? (p. 6)</li> <li>● Has the TV been switched On?</li> </ul>



## Information for Users on Collection and Disposal of Old Equipment and used Batteries



These symbols on the products, packaging, and/or accompanying documents mean that used electrical and electronic products and batteries should not be mixed with general household waste. For proper treatment, recovery and recycling of old products and used batteries, please take them to applicable collection points, in accordance with your national legislation and the Directives 2002/96/EC and 2006/66/EC.

By disposing of these products and batteries correctly, you will help to save valuable resources and prevent any potential negative effects on human health and the environment which could otherwise arise from inappropriate waste handling.



For more information about collection and recycling of old products and batteries, please contact your local municipality, your waste disposal service or the point of sale where you purchased the items.

Penalties may be applicable for incorrect disposal of this waste, in accordance with national legislation.

### **For business users in the European Union**

If you wish to discard electrical and electronic equipment, please contact your dealer or supplier for further information.



### **[Information on Disposal in other Countries outside the European Union]**

These symbols are only valid in the European Union. If you wish to discard these items, please contact your local authorities or dealer and ask for the correct method of disposal.

### **Note for the battery symbol (bottom two symbol examples):**

This symbol might be used in combination with a chemical symbol. In this case it complies with the requirement set by the Directive for the chemical involved.

Cd

## Customer's Record

The model number and serial number of this product may be found on its rear panel. You should note this serial number in the space provided below and retain this book, plus your purchase receipt, as a permanent record of your purchase to aid in identification in the event of theft or loss, and for Warranty Service purposes.

Model Number \_\_\_\_\_

Serial Number \_\_\_\_\_

## Panasonic Corporation

Web Site : <http://www.panasonic-europe.com>

© Panasonic Corporation 2009