

Panasonic

Operating Instructions

Personal Facsimile

Model No. **KX-FT982FX**

Facsimile
with Digital Answering System

Model No. **KX-FT988FX**

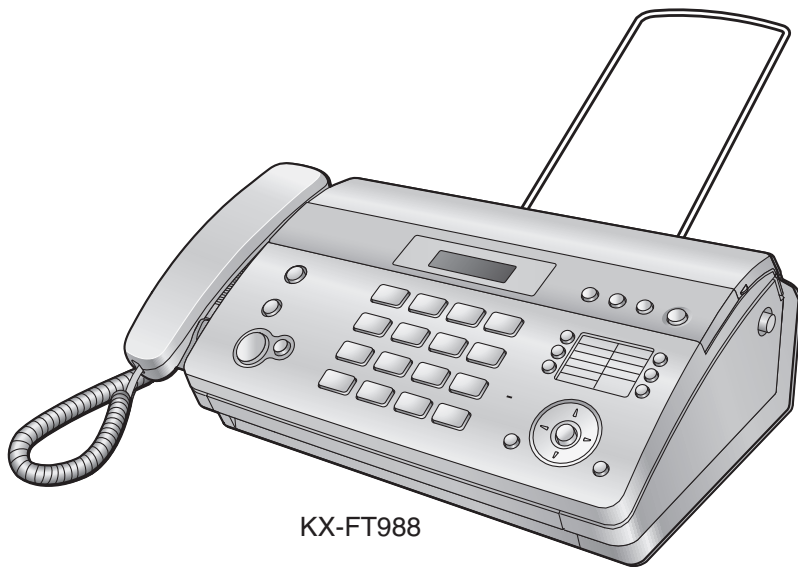

KX-FT988

Thank you for purchasing a Panasonic fax machine.

Please read these operating instructions before using the unit and save for future reference.

This unit is compatible with Caller ID. You must subscribe to the appropriate service of your service provider/telephone company.

To use in Czech and Slovakia, change the location setting (feature #74 on page 35).

Table of Contents

1. Installation and Quick Start

Accessories	
1.1 Included accessories.....	4
1.2 Accessory information.....	4
Connections and Set up	
1.3 Connections.....	4
1.4 Recording paper.....	5
Quick Start	
1.5 Fax sending / Copying.....	6
1.6 Fax receiving.....	6
1.7 Answering machine (KX-FT988 only).....	6

2. Important Information

Important safety instructions	
2.1 Important safety instructions.....	7
2.2 Information on Disposal for Users of Waste Electrical & Electronic Equipment (private households).....	8
2.3 For best performance.....	8

3. Preparation

Location of Controls	
3.1 Location of Controls.....	9
Finding the Controls	
3.2 Overview.....	10
Volume	
3.3 Adjusting volume.....	11
Initial Programming	
3.4 Dialling mode.....	11
3.5 Date and time.....	11
3.6 Your logo.....	12
3.7 Your fax number.....	13

4. Telephone

Making and Answering Calls	
4.1 Phonebook.....	14
4.2 One-touch dial feature.....	15
Caller ID	
4.3 Caller ID service.....	16
4.4 Viewing and calling back using caller information.....	16
4.5 Editing a caller's telephone number before calling back.....	17
4.6 Erasing caller information.....	18
4.7 Storing caller information into the phonebook / one-touch dial.....	18

5. Fax

Sending Faxes	
5.1 Sending a fax manually.....	20
5.2 Documents you can send.....	20
5.3 Sending a fax using the phonebook / one-touch dial.....	21
5.4 Broadcast transmission.....	22
Receiving Faxes	
5.5 Selecting the way to use your fax machine.....	23
5.6 Receiving a fax manually – Auto answer OFF.....	24
5.7 Receiving a fax automatically – Auto answer ON.....	25
5.8 Receive polling.....	26
5.9 Junk fax prohibitor (preventing fax reception from undesired callers).....	27

6. Copy

Copying	
6.1 Making a copy.....	28

7. Answering Machine (KX-FT988 only)

Greeting	
7.1 Recording your greeting message.....	29
Memo Message	
7.2 Leaving a message for others or yourself.....	29
Incoming Messages	
7.3 Listening to recorded messages.....	29
Remote Operation	
7.4 Operating from a remote location.....	31

8. Programmable Features

Features Summary	
8.1 Programming.....	32
8.2 Basic features.....	32
8.3 Advanced features.....	33
8.4 Direct commands for programming features.....	36

9. Help

Error Messages	
9.1 Error messages – Reports.....	38
9.2 Error messages – Display.....	38
Troubleshooting	
9.3 When a function does not work, check here.....	40

10.Maintenance

Jams

- 10.1 Recording paper jams 44
- 10.2 Document jams – sending..... 44

Cleaning

- 10.3 Document feeder / scanner glass
cleaning 45
- 10.4 Thermal head cleaning..... 45

11.General Information

Printed Reports

- 11.1 Reference lists and reports 46

Specifications

- 11.2 Specifications 47

Useful information

- 11.3 Character entry..... 48
- 11.4 Useful information 49

12.Index

- 12.1 Index..... 50

1. Installation and Quick Start

1.1 Included accessories

① Telephone line cord



② Handset



③ Handset cord

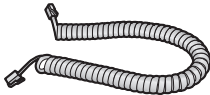

④ Recording paper

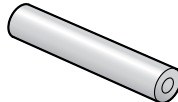

⑤ Paper stacker
(KX-FT988 only)



⑥ Operating instructions



Note:

- If any items are missing or damaged, contact the place of purchase.
- Save the original carton and packing materials for future shipping and transportation of the unit.

1.2 Accessory information

1.2.1 Available accessories

— Standard thermal recording paper*¹ (KX-A106):
216 mm × 30 m roll, with 25 mm core

*¹ Use only the included or specified recording paper. Using other recording paper may affect print quality and/or cause excessive wear to the thermal head.

1.3 Connections

Important:

- The unit will not function when there is a power failure. To make calls in emergency situations, you should connect a telephone that can function during a power failure to the telephone line.

① Paper stacker (KX-FT988 only)

- Make sure the paper stacker must not touch the wall.
- The paper stacker may not be shown in all illustrations in these operating instructions.

② Power cord

- Connect to the power outlet (220 V – 240 V, 50/60 Hz).

③ Telephone line cord

- Connect to [LINE] jack and a single telephone line jack.

④ [EXT] jack

⑤ Handset cord

⑥ Extension telephone (not included)

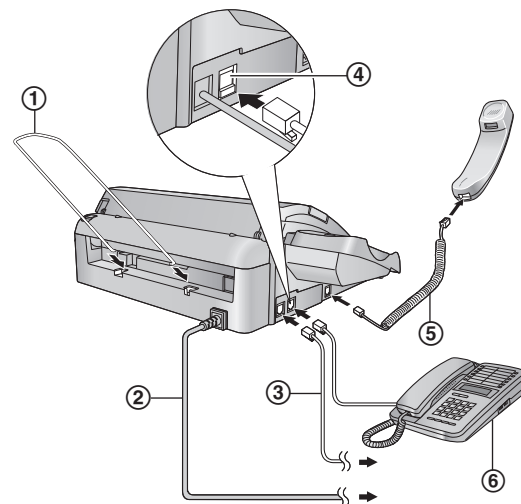

This model is designed to be used in East Europe, Czech and Slovakia. TO USE IN CZECH OR SLOVAKIA, CHANGE THE LOCATION SETTING (feature #74 on page 35).

Caution:

- When you operate this product, the power outlet should be near the product and easily accessible.
- Be sure to use the telephone line cord included in this unit.
- Do not extend the telephone line cord.
- Keep the unit away from walls as far as possible to prevent a recording paper jam.

Note:

- Before you can make calls, the dialling mode setting may need to be changed (page 11).

1.4 Recording paper

- ① Open the top cover by pressing the top cover release button (①).

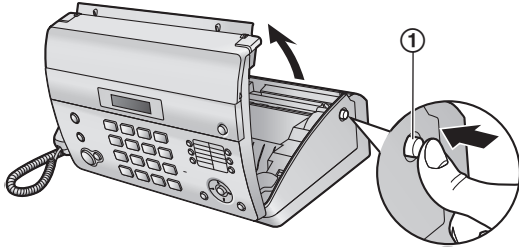

- ② Install the recording paper.

Correct

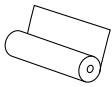

Incorrect

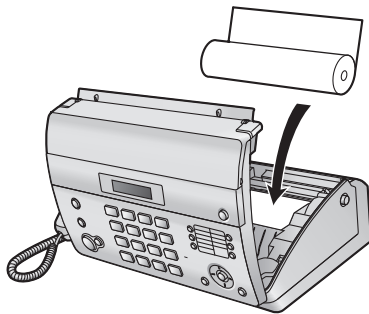
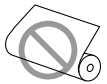

- ③ Insert the leading edge of the paper into the opening above the thermal head (①).

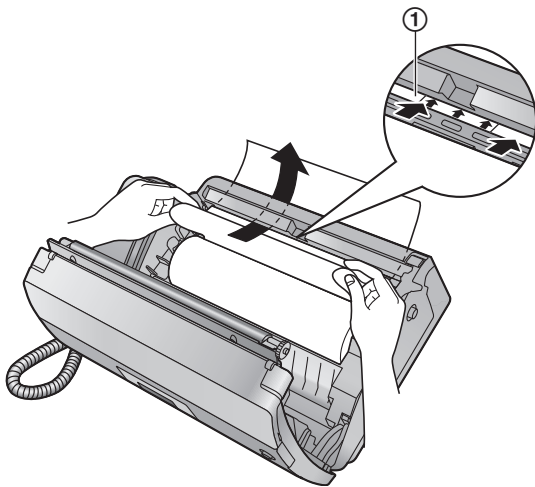

- ④ Pull the paper out of the unit.

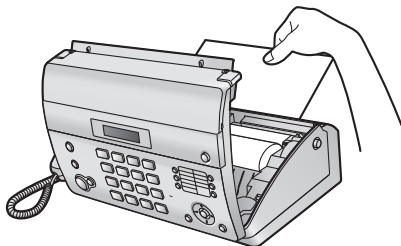

- Make sure that there is no slack in the paper roll.

- ⑤ Close the top cover securely by pushing down on both sides.



- ⑥ **For KX-FT982:**
Press **[FAX/START]**, then tear off the excess paper by pulling it towards you.

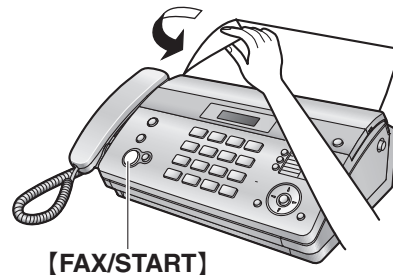

- For KX-FT988:**
Press **[FAX/START]** to cut the paper.

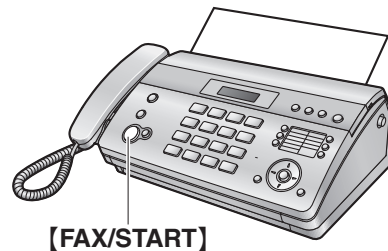

Note:

- If the paper is secured with glue or tape, cut approximately 15 cm from the beginning of the roll before installing it.
- When the power cord is connected, a message is printed each time the top cover is opened then closed. If the recording paper is installed upside down, the message will not be printed. Install the paper correctly.
- For accessory information, see page 4.

1. Installation and Quick Start

1.5 Fax sending / Copying

- 1 Open the document feeder tray.

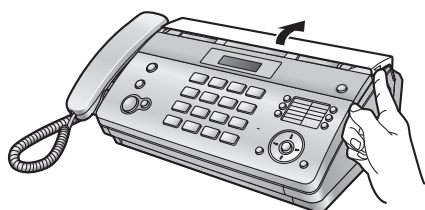

- 2 Adjust the document guides (1), and insert the document FACE DOWN.

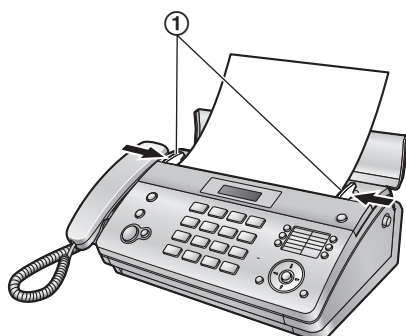

- 3 To send a fax:
Dial the fax number and press **[FAX/START]**.
To make a copy:
Press **[COPY]**.

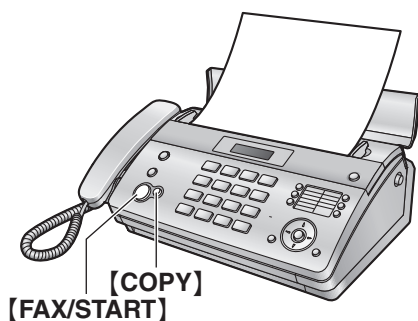

- For further details to send a fax, see page 20.
For further details to make a copy, see page 28.

1.6 Fax receiving

- 1 Lift the handset to answer the call.
- 2 To receive a fax document, press **[FAX/START]**.

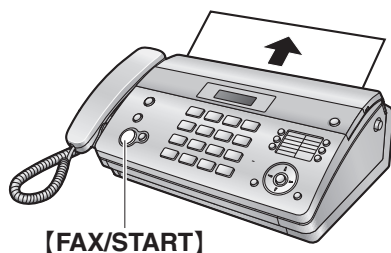

- For further details, see page 24.
- You can select how you want the unit to receive calls according to your needs (page 23).

1.7 Answering machine (KX-FT988 only)

1.7.1 Recording your own greeting message

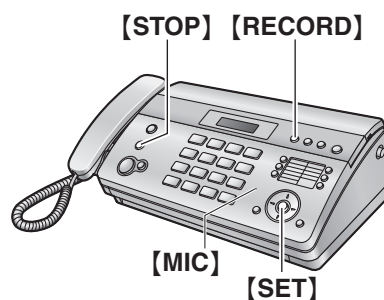

- 1 Press **[RECORD]**.
- 2 Press **[SET]**.
- 3 Speak clearly about 20 cm away from **[MIC]**, for up to 16 seconds.
- 4 To stop recording, press **[STOP]**.
 - For further details, see page 29.

1.7.2 Listening to recorded messages

The display will show the total number of recorded messages.

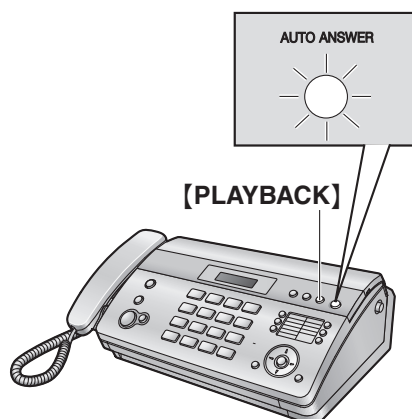

When the [AUTO ANSWER] indicator flashes:
Press **[PLAYBACK]**. New messages will be played.

When the [AUTO ANSWER] indicator is ON:
Press **[PLAYBACK]**. All messages will be played.

- For further details, see page 29.

2.1 Important safety instructions

When using this unit, basic safety precautions should always be followed to reduce the risk of fire, electric shock, or personal injury.

1. Read and understand all instructions.
2. Follow all warnings and instructions marked on this unit.
3. Unplug this unit from power outlets before cleaning. Do not use liquid or aerosol cleaners.
4. Do not use this unit near water, for example near a bathtub, wash bowl, kitchen sink, etc.
5. Place the unit securely on a stable surface. Serious damage and/or injury may result if the unit falls.
6. Do not cover slots and openings on the unit. They are provided for ventilation and protection against overheating. Never place the unit near radiators, or in a place where proper ventilation is not provided.
7. Use only the power source marked on the unit. If you are not sure of the type of power supplied to your home, consult your dealer or local power company.
8. For safety purposes this unit is equipped with a grounded plug. If you do not have this type of outlet, please have one installed. Do not defeat this safety feature by tampering with the plug.
9. Do not place objects on the power cord. Install the unit where no one can step or trip on the cord.
10. Do not overload power outlets and extension cords. This can result in the risk of fire or electric shock.
11. Never push any objects through slots in this unit. This may result in the risk of fire or electric shock. Never spill any liquid on the unit.
12. To reduce the risk of electric shock, do not disassemble this unit. Take the unit to an authorised service centre when service is required. Opening or removing covers may expose you to dangerous voltage or other risks. Incorrect reassembly can cause electric shock when the unit is subsequently used.
13. Unplug this unit from power outlets and refer servicing to an authorised service centre when the following conditions occur:
 - A. When the power cord is damaged or frayed.
 - B. If liquid has been spilled into the unit.
 - C. If the unit has been exposed to rain or water.
 - D. If the unit does not work normally by following the operating instructions. Adjust only controls covered by the operating instructions. Improper adjustment may require extensive work by an authorised service centre.
 - E. If the unit has been dropped or physically damaged.
 - F. If the unit exhibits a distinct change in performance.
14. During thunderstorms, avoid using telephones except cordless types. There may be a remote risk of an electric shock from lightning.

15. Do not use this unit to report a gas leak, when in the vicinity of the leak.

SAVE THESE INSTRUCTIONS

CAUTION:

- In the event of problems, you should contact your equipment supplier in the first instance.
- This equipment is designed for use on the Czech and Slovakia analogue telephone network.
- For use in other countries, please contact your equipment supplier.

Installation

- Never install telephone wiring during a lightning storm.
- Never install telephone jacks in wet locations unless the jack is specifically designed for wet locations.
- Never touch uninsulated telephone wires or terminals unless the telephone line has been disconnected at the network interface.
- Use caution when installing or modifying telephone lines.

WARNING:

- Never touch the plug with wet hands. Danger of electric shock exists.
- Completely insert the AC adaptor/power plug into the power outlet. Failure to do so may cause electric shock and/or excessive heat resulting in a fire.
- Regularly remove any dust, etc. from the AC adaptor/power plug by pulling it from the power outlet, then wiping with a dry cloth. Accumulated dust may cause an insulation defect from moisture, etc. resulting in a fire.
- Do not spill liquids (detergents, cleansers, etc.) onto the telephone line cord plug, or allow it to become wet at all. This may cause a fire. If the telephone line cord plug becomes wet, immediately pull it from the telephone wall jack, and do not use.
- To prevent the risk of fire or electrical shock, do not expose this product to rain or any type of moisture.
- Unplug this unit from power outlets if it emits smoke, an abnormal smell or makes unusual noise. These conditions can cause fire or electric shock. Confirm that smoke has stopped and contact an authorised service centre.

2. Important Information

2.2 Information on Disposal for Users of Waste Electrical & Electronic Equipment (private households)

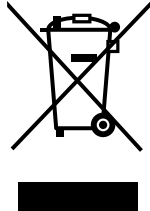

This symbol on the products and/or accompanying documents means that used electrical and electronic products should not be mixed with general household waste.

For proper treatment, recovery and recycling, please take these products to designated collection points, where they will be accepted on a free of charge basis. Disposing of this product correctly will help to save valuable resources and prevent any potential negative effects on human health and the environment which could otherwise arise from inappropriate waste handling. Please contact your local authority for further details of your nearest designated collection point. Penalties may be applicable for incorrect disposal of this waste, in accordance with national legislation.

For business users in the European Union

If you wish to discard electrical and electronic equipment, please contact your dealer or supplier for further information.

Information on Disposal in other Countries outside the European Union

This symbol is only valid in the European Union. If you wish to discard this product, please contact your local authorities or dealer and ask for the correct method of disposal.

2.3 For best performance

Environment

- Keep the unit away from electrical noise generating devices, such as fluorescent lamps and motors.
- The unit should be kept free from dust, high temperature and vibration.
- The unit should not be exposed to direct sunlight.
- Do not place heavy objects on top of the unit.
- The unit should be kept away from heat sources such as heaters, kitchen stoves, etc. It should not be placed in rooms where the temperature is less than 5 °C or greater than 35 °C. Damp basements should also be avoided.

Connection

- If any other device is connected on the same line, this unit may disturb the network condition of the device.
- If you use the unit with a computer and your internet provider instructs you to install a filter (①), please connect the telephone line cord as follows.

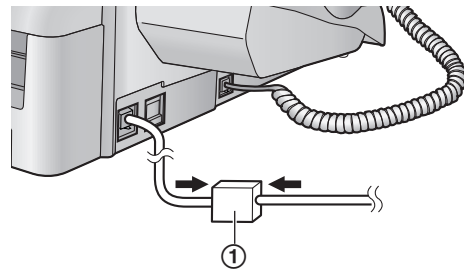

Speakerphone operation (KX-FT988 only)

- Use the speakerphone in a quiet room.

Routine care

- Wipe the outer surface of the unit with a soft cloth. Do not use benzine, thinner, or any abrasive powder.

3.1 Location of Controls

KX-FT982

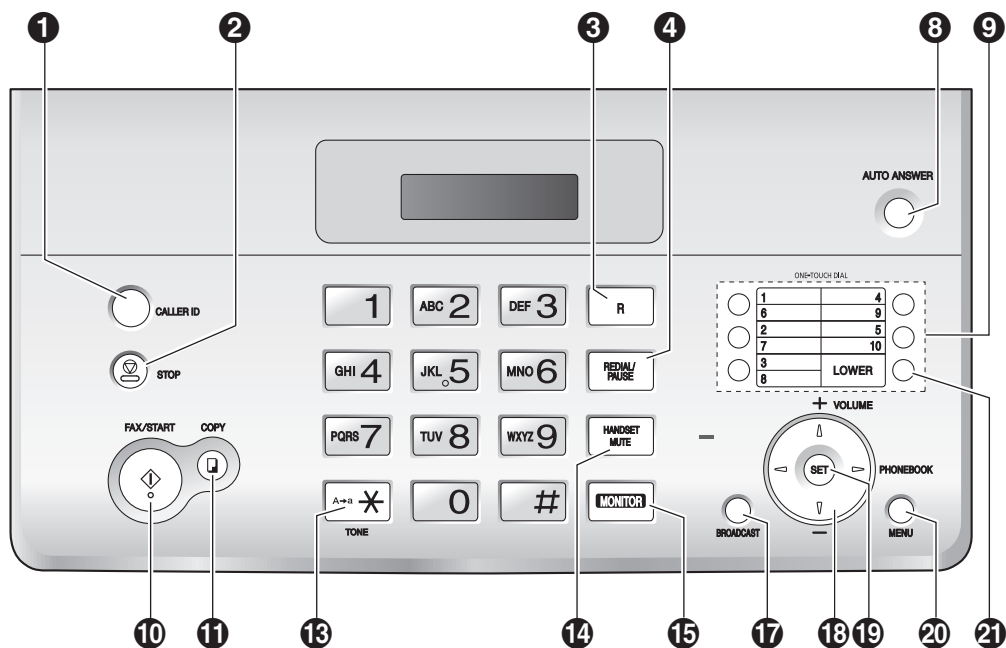

KX-FT988

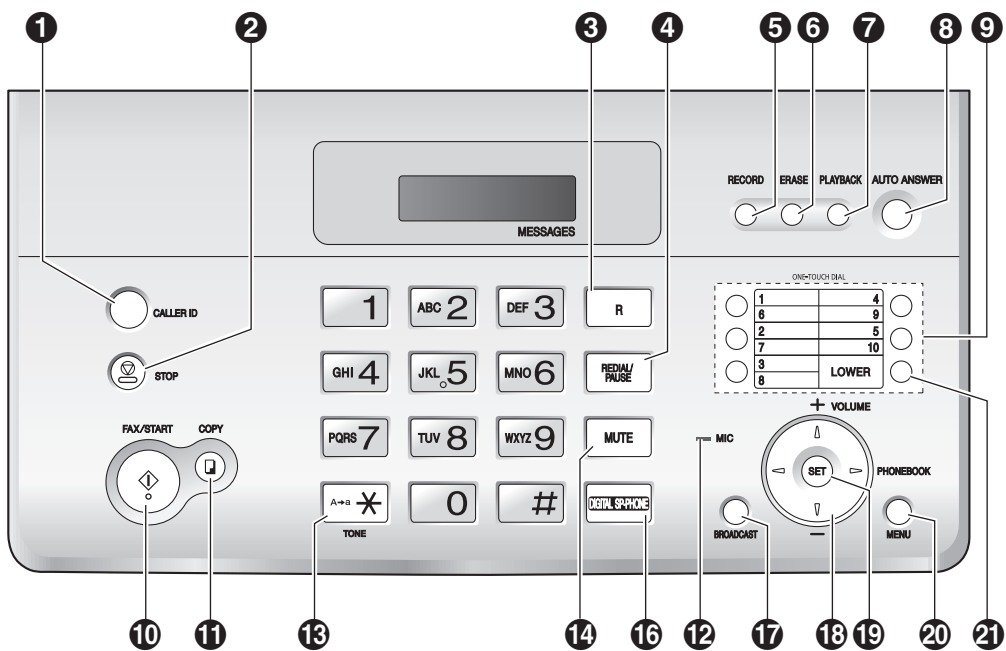

3. Preparation

- ① **[CALLER ID]**
 - To use Caller ID features (page 16, 18).
- ② **[STOP]**
 - To stop an operation or programming session.
 - To erase a character/number (page 12). Press and hold to erase all characters/numbers.
- ③ **[R]**
 - To access special telephone services or for transferring extension calls.
- ④ **[REDIAL/PAUSE]**
 - To redial the last number dialed. If the line is busy when you make a call using the **[MONITOR]** (KX-FT982)/**[DIGITAL SP-PHONE]** (KX-FT988) button, the unit will automatically redial the number up to 11 times for phone calls and 5 times for faxes.
 - To insert a pause during dialling.
- ⑤ **[RECORD]** (KX-FT988 only)
 - To record your greeting message (page 29).
 - To record a memo message (page 29).
- ⑥ **[ERASE]** (KX-FT988 only)
 - To erase messages (page 30).
 - To erase a stored item (page 15).
- ⑦ **[PLAYBACK]** (KX-FT988 only)
 - To play messages (page 29).
- ⑧ **[AUTO ANSWER]**
 - To turn the auto answer setting ON/OFF (page 23, 24, 25).
- ⑨ **Station keys**
 - To use one-touch dial feature (page 15).
- ⑩ **[FAX/START]**
 - To start sending or receiving a fax.
- ⑪ **[COPY]**
 - To copy a document (page 28).
- ⑫ **[MIC]** (KX-FT988 only)
 - The built-in microphone.
- ⑬ **[TONE]**
 - To change from pulse to tone temporarily during dialling when your line has rotary pulse services.
- ⑭ **[HANDSET MUTE]** (KX-FT982 only)
[MUTE] (KX-FT988 only)
 - To mute your voice to the other party during a conversation. Press this button again to resume the conversation.
- ⑮ **[MONITOR]** (KX-FT982 only)
 - To initiate dialling without lifting the handset.
- ⑯ **[DIGITAL SP-PHONE]** (KX-FT988 only)
 - For speakerphone operation (page 8, 15).
- ⑰ **[BROADCAST]**
 - To transmit a document to multiple parties (page 22).
- ⑱ **Navigator/[VOLUME][PHONEBOOK]**
 - To search for a stored item (page 14, 21).
 - To select features or feature settings during programming (page 32).

- To adjust volume (page 11).
 - To open a phonebook.
- ⑲ **[SET]**
 - To store a setting during programming.
 - ⑳ **[MENU]**
 - To initiate or exit programming.
 - ㉑ **[LOWER]**
 - To select stations 6-10 for the one-touch dial feature (page 15, 19, 21).

3.2 Overview

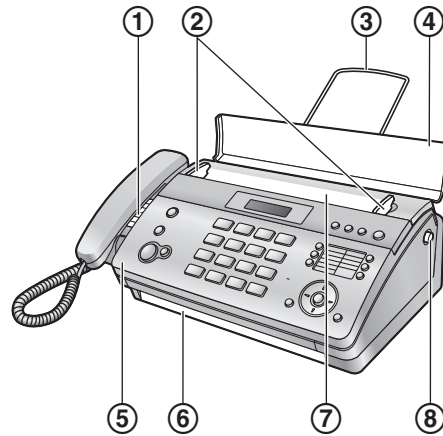

* The pictured model is KX-FT988.

- ① **Speaker**
- ② **Document guides**
- ③ **Paper stacker (KX-FT988 only)**
 - The paper stacker may not be shown in all illustrations in these operating instructions.
- ④ **Document feeder tray**
- ⑤ **Top cover**
- ⑥ **Document exit**
- ⑦ **Document entrance**
- ⑧ **Top cover release button**

3.3 Adjusting volume

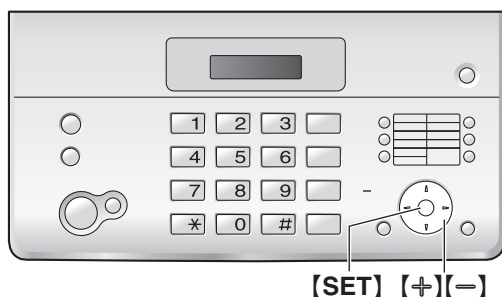

Ringer volume

While the unit is idle, press [+] or [-].

- If any documents are in the document entrance, you cannot adjust the volume. Confirm that there are no documents in the entrance.

To turn the ringer OFF

1. Press [-] repeatedly to display "RINGER OFF=OK?".
2. Press [SET].
 - When a call is received, the unit will not ring and will display "INCOMING CALL".
 - To turn the ringer back ON, press [+].

Ringer tone

- You can select the ringer tone from one of 3 patterns (feature #17 on page 33).

Handset receiver volume

While using the handset, press [+] or [-].

Speaker volume

While using the monitor/speakerphone, press [+] or [-].

Answering machine volume (KX-FT988 only)

While listening to messages, press [+] or [-].

3.4 Dialling mode

If you cannot dial (page 20), change this setting depending on your telephone line service. For tone dial service, select "TONE" (default). For rotary pulse dial service, select "PULSE".

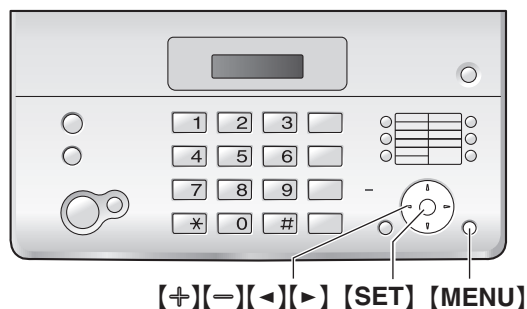

- 1 Press [MENU].

```
SYSTEM SETUP
PRESS [←] [→]
```

- 2 Press [←] or [→] repeatedly to display the following.

```
DIAL MODE
=TONE [±]
```

- 3 Press [+] or [-] repeatedly to display the desired setting.
- 4 Press [SET].
 - The next feature will be displayed.
- 5 Press [MENU].

3.5 Date and time

You must set the date and time.

- The other party's fax machine will print the date and time on each page you send according to your unit's date and time setting.
- The accuracy of the clock is approximately ± 60 seconds a month.
- If a power failure occurs, the date and time setting may be lost. If the correct date and time is not displayed after the power has been restored, set the date and time again.

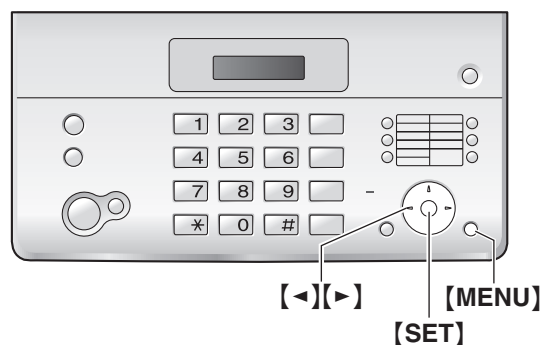

- 1 Press [MENU].

```
SYSTEM SETUP
PRESS [←] [→]
```

- 2 Press [←] or [→] repeatedly to display the following.

```
SET DATE & TIME
PRESS SET
```

- 3 Press [SET].
 - The cursor (■) will appear on the display.

```
D: 01/M: 01/Y: 08
TIME: 00:00
```

- 4 Enter the current date/month/year by selecting 2 digits for each.

Example: 10 August, 2008

Press [1][0] [0][8] [0][8].

```
D: 10/M: 08/Y: 08
TIME: 00:00
```

3. Preparation

- 5 Enter the current hour/minute by selecting 2 digits for each. Press **[*]** repeatedly to select “**AM**”, “**PM**”, or 24-hour time entry.

- When neither “**AM**” nor “**PM**” is displayed, 24-hour time entry is selected.

Example: 15:20 (24-hour time entry)

Press **[1][5][2][0]**.

D: 10/M: 08/Y: 08
TIME: 15:20

- 6 Press **[SET]**.
- The next feature will be displayed.
- 7 Press **[MENU]**.

To correct a mistake

Press **[◀]** or **[▶]** to move the cursor to the incorrect number, and make the correction.

3.6 Your logo

Your logo will be printed on the top of each page sent from your unit.

The logo can be your name or the name of your company.

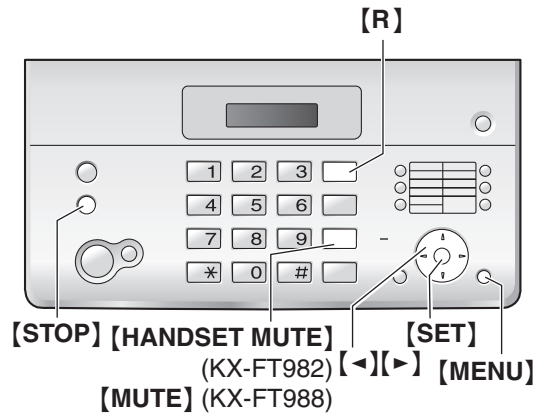

- 1 Press **[MENU]**.

SYSTEM SETUP
PRESS [◀ ▶]

- 2 Press **[◀]** or **[▶]** repeatedly to display the following.

YOUR LOGO
PRESS SET

- 3 Press **[SET]**.
- The cursor (■) will appear on the display.

LOGO= ■
[#:ABC]

- 4 Enter your logo, up to 30 characters (see page 48 for character entry).

- To enter a hyphen, press **[R]**.
- To insert a space, press **[HANDSET MUTE]** (KX-FT982)/**[MUTE]** (KX-FT988).

- 5 Press **[SET]**.
- The next feature will be displayed.

- 6 Press **[MENU]**.

To correct a mistake

1. Press **[◀]** or **[▶]** to move the cursor to the incorrect character.
2. Press **[STOP]**.
 - To erase all characters, press and hold **[STOP]**.
3. Enter the correct character.

3.7 Your fax number

Your fax number will be printed on the top of each page sent from your unit.

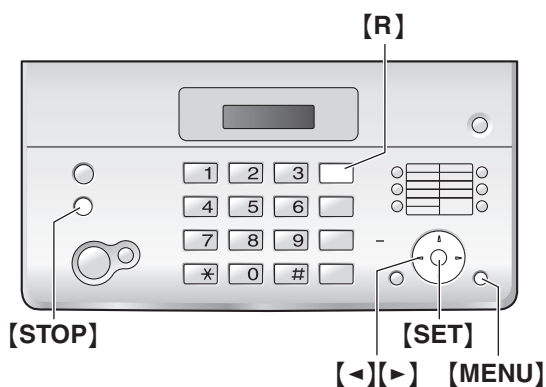

- 1 Press **[MENU]**.

```
SYSTEM SETUP
PRESS [← ▶]
```

- 2 Press **[←]** or **[▶]** repeatedly to display the following.

```
YOUR FAX NO.
PRESS SET
```

- 3 Press **[SET]**.
 - The cursor (█) will appear on the display.

```
NO. = █
```

- 4 Enter your fax number, up to 20 digits.

Example:

```
NO. =1234567█
```

- 5 Press **[SET]**.
 - The next feature will be displayed.
- 6 Press **[MENU]**.

Note:

- The **[*]** button enters a "+" and the **[#]** button enters a space.

Example: +234 5678

Press **[*][2][3][4][#][5][6][7][8]**.

- To enter a hyphen in a telephone number, press **[R]**.

To correct a mistake

1. Press **[←]** or **[▶]** to move the cursor to the incorrect number.
2. Press **[STOP]**.
 - To erase all numbers, press and hold **[STOP]**.
3. Enter the correct number.

4. Telephone

4.1 Phonebook

The phonebook allows you to make calls without having to dial manually. You can store 100 names and telephone numbers to the phonebook.

- You can also send faxes using the phonebook (page 21).

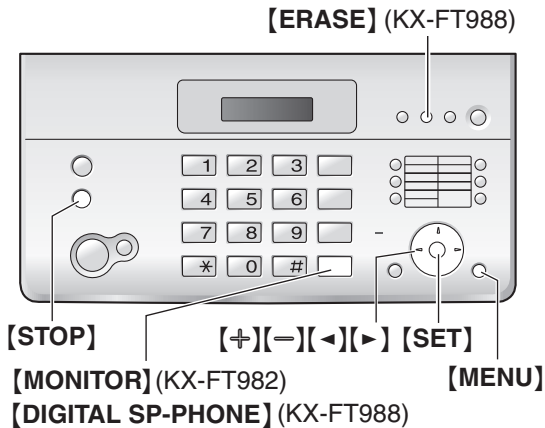

4.1.1 Storing phonebook items

- 1 Press **[MENU]** repeatedly to display “PHONEBOOK SET”.
- 2 Press **[*]**.
- 3 Press **[▶]**.
 - The display shows the number of items in the phonebook briefly.
- 4 Enter the name, up to 16 characters (see page 48 for instructions).
- 5 Press **[SET]**.
- 6 Enter the telephone number, up to 24 digits.
- 7 Press **[SET]**.
 - To program other items, repeat steps 4 to 7.
- 8 Press **[MENU]**.

Helpful hints:

- You can confirm the stored items by printing the telephone number list (page 46).

To correct a mistake

1. Press **[◀]** or **[▶]** to move the cursor to the incorrect character/number.
2. Press **[STOP]**.
 - To erase all characters/numbers, press and hold **[STOP]**.
3. Enter the correct character/number.

4.1.2 Making a phone call using the phonebook

Before using this feature, store the desired names and telephone numbers in the phonebook (page 14).

- 1 Press **[▶]**.

- 2 Press **[+]** or **[-]** repeatedly to display the desired item.
- 3 Lift the handset or press **[MONITOR]** (KX-FT982)/**[DIGITAL SP-PHONE]** (KX-FT988).
 - The unit will start dialing automatically.

To search for a name by initial

Example: “LISA”

1. Press **[▶]**.
2. Press **[+]** or **[-]** to enter the phonebook.
3. Press **[5]** repeatedly to display any name with the initial “L” (see the character table, page 48).
 - To search for symbols (not letters or numbers), press **[1]**.
4. Press **[-]** repeatedly to display “LISA”.
 - To stop the search, press **[STOP]**.
 - To dial the displayed party, lift the handset or press **[MONITOR]** (KX-FT982)/**[DIGITAL SP-PHONE]** (KX-FT988).

4.1.3 Editing a stored item

- 1 Press **[▶]**.
- 2 Press **[+]** or **[-]** repeatedly to display the desired item.
- 3 Press **[MENU]**.
- 4 Press **[*]**.
 - If you do not need to edit the name, skip to step 6.
- 5 Edit the name. For further details, see the storing procedure on page 14.
- 6 Press **[SET]**.
 - If you do not need to edit the telephone number, skip to step 8.
- 7 Edit the telephone number. For further details, see the storing procedure on page 14.
- 8 Press **[SET]**.

4.1.4 Erasing a stored item

- 1 Press **[▶]**.
- 2 Press **[+]** or **[-]** repeatedly to display the desired item.
- 3 Press **[MENU]**.
- 4 Press **[#]**.
 - To cancel erasing, press **[STOP]**.
- 5 Press **[SET]**.

Another method to erase a stored item (KX-FT988 only)

1. Press **[▶]**.
2. Press **[+]** or **[-]** repeatedly to display the desired item.
3. Press **[ERASE]**.
 - To cancel erasing, press **[STOP]**.
4. Press **[SET]**.

4.2 One-touch dial feature

For rapid access to frequently dialed numbers, the unit provides the one-touch dial feature (10 items).

- You can also send faxes using the one-touch dial feature (page 21).

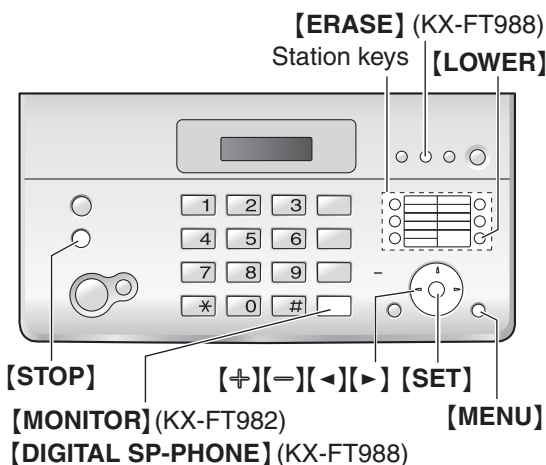

4.2.1 Storing one-touch dial items

- Press **[MENU]** repeatedly to display "PHONEBOOK SET".
- Press **[*]**.
- Select the desired station key.
For stations 1–5:
Press one of the station keys.
For stations 6–10:
Press **[LOWER]**, then press one of the station keys.
- Enter the name, up to 16 characters (see page 48 for instructions).
- Press **[SET]**.
- Enter the telephone number, up to 24 digits.
- Press **[SET]**.
• To program other items, repeat steps 3 to 7.
- Press **[MENU]**.

To correct a mistake

- Press **[<]** or **[>]** to move the cursor to the incorrect character/number.
- Press **[STOP]**.
• To erase all characters/numbers, press and hold **[STOP]**.
- Enter the correct character/number.

4.2.2 Making phone calls using the one-touch dial

Before using this feature, store the desired names and telephone numbers for the one-touch dial feature (page 15).

- Lift the handset or press **[MONITOR]** (KX-FT982)/**[DIGITAL SP-PHONE]** (KX-FT988).
- Select the desired station key.
For stations 1–5:
Press the desired station key.
For stations 6–10:
Press **[LOWER]**, then press the desired station key.
• The unit will start dialling automatically.

4.2.3 Editing a stored item

- Press **[>]**.
- Press **[+]** or **[–]** repeatedly to display the desired item.
- Press **[MENU]**.
- Press **[*]**.
• If you do not need to edit the name, skip to step 6.
- Edit the name. For further details, see the storing procedure on page 15.
- Press **[SET]**.
• If you do not need to edit the telephone number, skip to step 8.
- Edit the telephone number. For further details, see the storing procedure on page 15.
- Press **[SET]**.

4.2.4 Erasing a stored item

- Press **[>]**.
- Press **[+]** or **[–]** repeatedly to display the desired item.
- Press **[MENU]**.
- Press **[#]**.
• To cancel erasing, press **[STOP]**.
- Press **[SET]**.

Another method to erase a stored item (KX-FT988 only)

- Press **[>]**.
- Press **[+]** or **[–]** repeatedly to display the desired item.
- Press **[ERASE]**.
• To cancel erasing, press **[STOP]**.
- Press **[SET]**.

4. Telephone

4.3 Caller ID service

This unit is compatible with Caller ID service offered by your local telephone company. To use this feature, you must subscribe to Caller ID service.

Important:

- This unit is designed in accordance with the ETS (European Telecommunication Standard) and only supports the basic CLIP (Calling Line Identification Presentation) features.
- This unit will only display the caller's telephone number and name.
- This unit will not support future additional telephone services.
- Depending on the service of the local telephone company, the date/time of the call or the caller's name may not be displayed.

Make sure the following ring setting is set to 2 or more rings beforehand.

- For KX-FT982: FAX ring setting (feature #06 on page 32) and TEL/FAX ring setting (feature #78 on page 37)
- For KX-FT988: FAX ring setting (feature #06 on page 32), TAM/FAX ring setting (feature #06 on page 33) and TEL/FAX ring setting (feature #78 on page 37)

4.3.1 How Caller ID is displayed

When an outside call is received, the calling party's telephone number or name will be displayed. You then have the option of whether or not to answer the call. The unit will automatically store caller information (telephone number, name, date and time of the call) from the 30 most recent callers. Caller information is stored by the most recent to the oldest call. When the 31st call is received, the oldest call is deleted.

Caller information can be viewed on the display one item at a time (page 16) or confirmed by printing the Caller ID list (page 46).

Note:

- Caller information can be displayed up to 16 digits/characters.
- When caller information is received and it matches a telephone number stored in the unit's phonebook, the stored name will be displayed.
- If the unit is connected to a PBX (Private Branch Exchange) system, caller information may not be received properly. Consult your PBX supplier.
- If the unit cannot receive caller information, the following will be displayed:
 - “OUT OF AREA”: The caller dialed from an area which does not provide Caller ID service.
 - “PRIVATE CALLER”: The caller requested not to send caller information.
 - “LONG DISTANCE”: The caller made a long distance call.

To confirm caller information by printing the Caller ID list

- To print manually, see page 46.
- To print automatically after every 30 new calls, activate feature #26 (page 34).

4.4 Viewing and calling back using caller information

You can easily view caller information and call back.

Important:

- If the area code of the received telephone number is the same as yours, the area code may need to be deleted before calling back. This may only apply to some areas. To edit the number, see page 17.

The display will show the number of new calls in standby mode.

Example:

10 CALLS 10:59

[CALLER ID]



[FAX/START] [+][-]
[STOP] [MONITOR] (KX-FT982)
 [DIGITAL SP-PHONE] (KX-FT988)

- 1 Press **[CALLER ID]**.
- 2 Press **[-]** to search from the recently received caller information.
 - If you press **[+]**, the display order will be reversed.
- 3 Lift the handset or press **[MONITOR]** (KX-FT982)/**[DIGITAL SP-PHONE]** (KX-FT988) to return the call.
 - The unit will start dialling automatically.
 - To send a fax, insert the document FACE DOWN and press **[FAX/START]**.

To change the way caller information is displayed

Press **[CALLER ID]** repeatedly after the caller information is displayed.

Example:

SAM LEE 11:20 20 Jul. ✓
↓
1345678901 11:20 20 Jul. ✓

4.4.1 Symbols and operations for caller information

What “√” means

“√” on the display means the call has already been viewed or answered.

If the same person calls more than once

The number of times the same caller called (“×2” to “×9”) will be displayed. Only the date and time of the most recent call will be stored.

Example: The same person called 3 times.

SAM LEE
10:30 20 Jul. ×3

Display while viewing

- When the unit could not receive a name, the display will show “NO NAME RCVD”.
- When no calls have been received, the display will show “NO ITEMS STORED”.

To stop viewing

Press **[STOP]**.

4.5 Editing a caller's telephone number before calling back

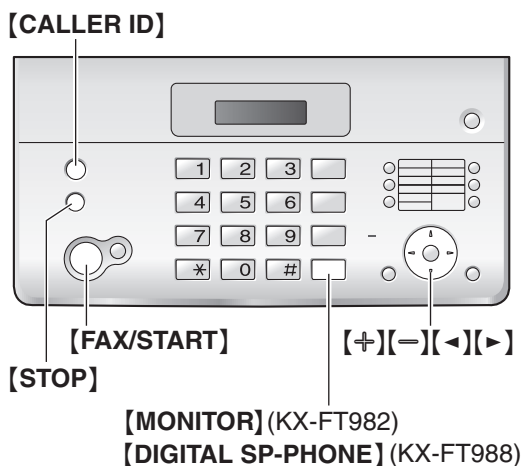

- 1 Press **[CALLER ID]**.
- 2 Press **[+]** or **[-]** repeatedly to display the desired item.
- 3 Press **[CALLER ID]** to display the telephone number.
- 4 To insert a number in front of the telephone number, press the desired dial key (**[0]** to **[9]**).
 - You can also initiate the editing mode by pressing **[*]**.
- 5 Lift the handset or press **[MONITOR]** (KX-FT982)/**[DIGITAL SP-PHONE]** (KX-FT988) to call back the edited number.
 - The unit will start dialling automatically.

- To send a fax, insert the document FACE DOWN and press **[FAX/START]**.

Note:

- The edited telephone number will not be saved as caller information. To store it into the phonebook, see page 18.

To correct a mistake

1. Press **[<]** or **[>]** to move the cursor to the incorrect number.
2. Press **[STOP]** to delete the number.
3. Enter the correct number.

To delete a number

Press **[<]** or **[>]** to move the cursor to the number you want to delete and press **[STOP]**.

To insert a number

1. Press **[<]** or **[>]** to move the cursor to the position to the right of where you want to insert the number.
2. Enter the number.

4. Telephone

4.6 Erasing caller information

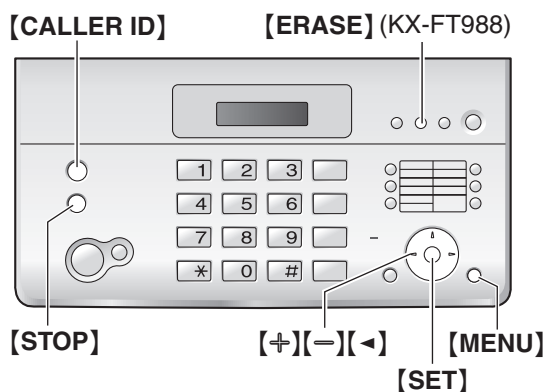

Erasing all caller information

1. Press **[MENU]** repeatedly to display "CALLER SETUP".
2. Press **[SET]**.
 - "CALL LIST ERASE" will be displayed.
3. Press **[SET]**.
 - To cancel erasing, press **[STOP]** 3 times.
4. Press **[SET]**.
5. Press **[STOP]**.

Erasing specific caller information

1. Press **[CALLER ID]**.
2. Press **[+]** or **[-]** repeatedly to display the desired item.
3. Press **[<]**.
 - To cancel erasing, press **[STOP]** 2 times.
4. Press **[SET]**.
 - To erase other items, repeat steps 2 to 4.
5. Press **[STOP]**.

Another method to erase all caller information (KX-FT988 only)

1. Press **[CALLER ID]**.
2. Press **[ERASE]**.
 - To cancel erasing, press **[STOP]**.
3. Press **[SET]**.

Another method to erase a specific caller information (KX-FT988 only)

1. Press **[CALLER ID]**.
2. Press **[+]** or **[-]** repeatedly to display the desired item.
3. Press **[ERASE]**.
 - To erase other items repeat steps 2 to 3.
4. Press **[STOP]**.

4.7 Storing caller information into the phonebook / one-touch dial

Important:

- This feature is not available if the caller information does not include a telephone number.

4.7.1 Into the phonebook

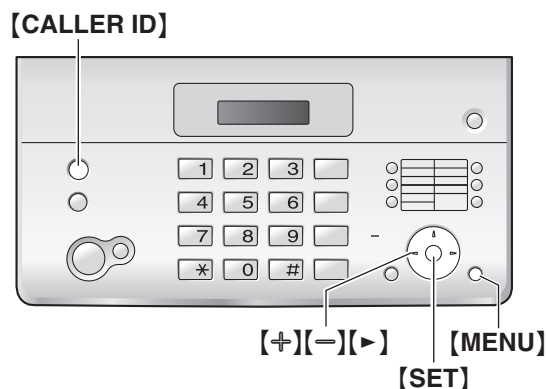

- 1 Press **[CALLER ID]**.
- 2 Press **[+]** or **[-]** repeatedly to display the desired item.
- 3 Press **[MENU]**.
- 4 Press **[>]**.
 - If you do not need to edit the name, skip to step 6.
- 5 If a name is required, enter up to 16 characters for the name (page 48).
- 6 Press **[SET]**.
 - If the number requires editing, see page 17.
- 7 Press **[SET]**.

Note:

- You can confirm the stored items in the phonebook by printing the telephone number list (page 46).
- To edit a name, see page 14.

4.7.2 Into the one-touch dial

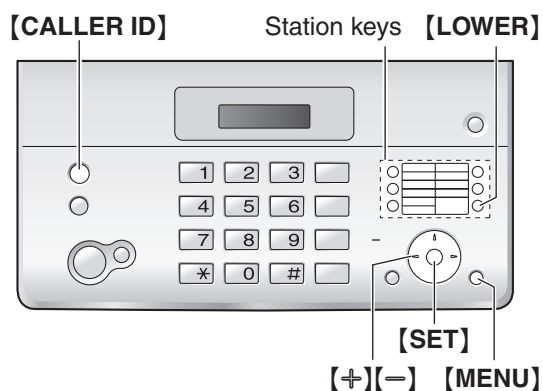

- 1 Press **[CALLER ID]**.
 - 2 Press **[+]** or **[−]** repeatedly to display the desired item.
 - 3 Press **[MENU]**.
 - 4 Select a station key.
 - For stations 1–5:**
Press the desired station key.
 - For stations 6–10:**
Press **[LOWER]**, then press the desired station key.
 - If you do not need to edit the name, skip to step 6.
 - 5 If a name is required, enter up to 16 characters for the name (page 48).
 - 6 Press **[SET]**.
 - If the number requires editing, see page 17.
 - 7 Press **[SET]**.
- Note:**
- You can confirm the stored items in the one-touch dial by printing the telephone number list (page 46).
 - To edit a name, see page 14.

5.1 Sending a fax manually

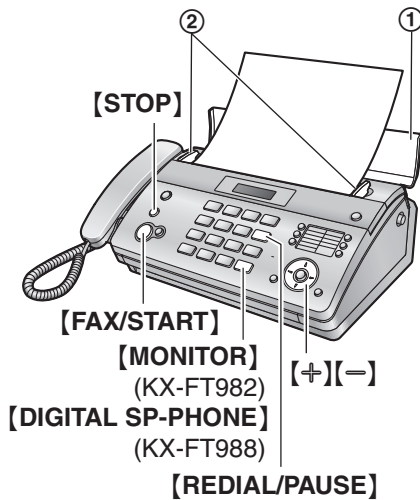

- 1 Open the document feeder tray (①), then adjust the width of the document guides (②) to fit the actual size of the document.
- 2 Insert the document (up to 10 pages) FACE DOWN until a single beep is heard and the unit grasps the document.
 - If the document guides are not adjusted to fit the document, re-adjust them.
- 3 If necessary, press [+] or [-] repeatedly to select the desired resolution.
- 4 Lift the handset or press [MONITOR] (KX-FT982)/ [DIGITAL SP-PHONE] (KX-FT988).
- 5 Dial the fax number.
- 6 **When a fax tone is heard:**
Press [FAX/START].

When the other party answers your call:

Ask them to press their start button. When the fax tone is heard, press [FAX/START].
If you pressed [MONITOR] (KX-FT982) in step 4, lift the handset before speaking.

Note:

- After pressing [FAX/START], you can replace the handset.

To select the resolution

Select the desired resolution according to the type of document.

- "STANDARD": For printed or typewritten documents with normal-sized characters.
- "FINE": For documents with small print.
- "SUPER FINE": For documents with very small print. This setting is effective only when the other party has a compatible fax machine.
- "PHOTO": For documents containing photographs, shaded drawings, etc.

- Using the "FINE", "SUPER FINE" and "PHOTO" settings will increase transmission time.
- If the resolution setting is changed during feeding, it will be effective from the next page.

To redial the last number

1. Press [REDIAL/PAUSE].
2. Press [FAX/START].
 - If the line is busy, the unit will automatically redial the number up to 5 times.
 - To cancel redialling, press [STOP].

To send more than 10 pages at a time

Insert the first 10 pages of the document. Add the other pages (up to 10 at a time) on top of the previously inserted pages before the last page feeds into the unit.

To predial a fax number

You can dial the fax number first before inserting the document. This is convenient if you need to refer to the document for the other party's fax number.

1. Enter the fax number.
2. Insert the document.
3. Press [FAX/START].

To stop transmission

Press [STOP].

Printing a sending report

A sending report provides you with a printed record of transmission results. To print sending reports, make sure feature #04 is activated (page 32). For an explanation of error messages, see page 38.

Printing a journal report

A journal report provides you with a printed record of the 30 most recent faxes. To print manually, see page 46. To print automatically after every 30 new fax transmissions and receptions, make sure feature #22 is activated (page 33). For an explanation of error messages, see page 38.

5.2 Documents you can send

Minimum document size

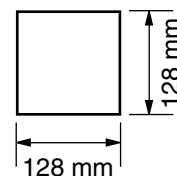

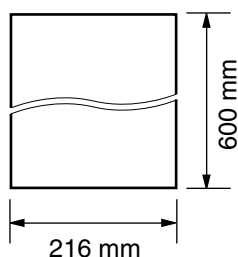
Maximum document size**Effective scanning area**

- Shaded area will be scanned.

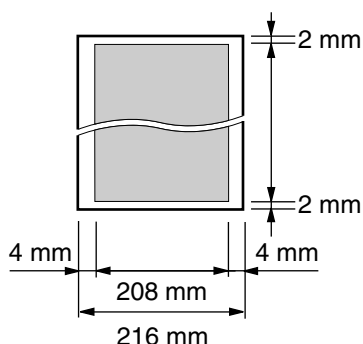
**Document weight**

- Single sheet: 45 g/m² to 90 g/m²
- Multiple sheets: 60 g/m² to 80 g/m²

Note:

- Remove clips, staples or other fasteners.
- Do not send or copy documents that are on the following types of paper: (Make a copy of the document using another copier and send the copy.)
 - Chemically treated paper such as carbon or carbonless duplicating paper
 - Electrostatically charged paper
 - Badly curled, creased or torn paper
 - Paper with a coated surface
 - Paper with a faint image
 - Paper with printing on the opposite side that can be seen through the other side, such as newsprint.
- Check that ink, paste or correction fluid has dried completely.
- To send a document with a width of less than 210 mm, we recommend using a copy machine to copy the original document onto A4 or letter-sized paper, then sending the copied document.

5.3 Sending a fax using the phonebook / one-touch dial

Before using this feature, store the desired names and telephone numbers into the phonebook (page 14) or one-touch dial (page 15).

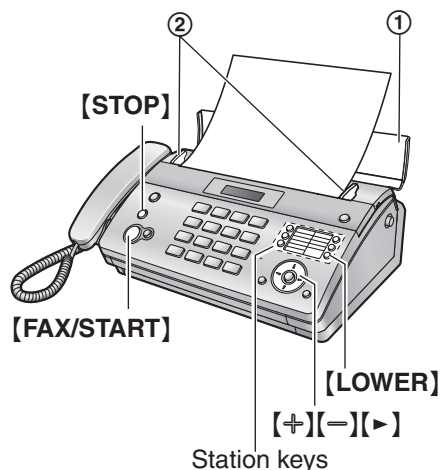

- 1 Open the document feeder tray (①), then adjust the width of the document guides (②) to fit the actual size of the document.
- 2 Insert the document (up to 10 pages) FACE DOWN until a single beep is heard and the unit grasps the document.
 - If the document guides are not adjusted to fit the document, re-adjust them.
- 3 If necessary, press **[+]** or **[-]** repeatedly to select the desired resolution (page 20).
- 4 Enter the fax number.

Using one-touch dial:**For stations 1–5**

Press the desired station key.

For stations 6–10

Press **[LOWER]**, then press the desired station key.

Using phonebook:

Press **[>]**, then **[+]** or **[-]** repeatedly to display the desired item.

- 5 Press **[FAX/START]**.

Fax auto redial

If the line is busy or if there is no answer, the unit will automatically redial the number up to 5 times.

- To cancel redialling, press **[STOP]**.

If your unit does not send a fax

- Confirm that you have entered the number correctly, and that the number is a fax number.
- Confirm that the other party's fax machine is answering by turning ON the connecting tone feature (feature #76 on page 35).

5.4 Broadcast transmission

By storing phonebook items (page 14) or one-touch dial (page 15) into the broadcast memory, you can send the same document to multiple parties (up to 20). Your programmed items will remain in the broadcast memory, allowing frequent re-use.

- Both phonebook items and one-touch dial can be stored into the broadcast memory.

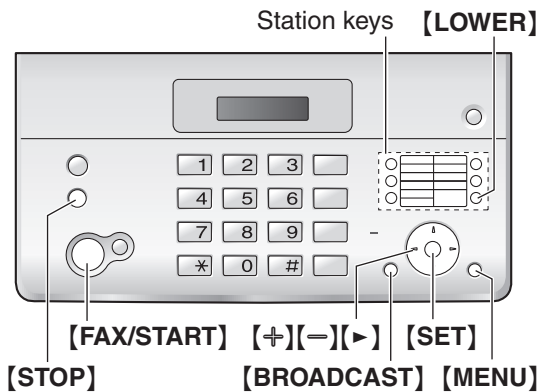

5.4.1 Programming items into the broadcast memory

- 1 Press **[MENU]** repeatedly to display “**BROADCAST SET**”.
- 2 Press **[⇄]**.
- 3 Program items.

Using stations 1–5:
Press the desired station key.

Using stations 6–10:
Press **[LOWER]**, then press the desired station key.

Using phonebook:
Press **[+]** or **[–]** repeatedly to display the desired item and press **[SET]**.

 - To program other items, repeat this step (up to 20 items).
 - If you program the wrong item, press **[STOP]** to erase the item.
- 4 Press **[SET]**.
- 5 Press **[STOP]**.

Note:

- Confirm the stored items by printing a broadcast programming list (page 46).

5.4.2 Adding a new item into the broadcast memory

After initial programming, you can add new items (up to a combined total of 20).

- 1 Press **[▶]**.

- 2 Press **[+]** or **[–]** repeatedly to display “**<BROADCAST>**”.
- 3 Press **[MENU]**.
- 4 Press **[*]**.
- 5 Press **[+]** or **[–]** repeatedly to display the desired item you want to add.
- 6 Press **[SET]**.
 - To add other items, repeat steps 5 and 6 (up to 20 items).
- 7 Press **[STOP]**.

5.4.3 Erasing a stored item from the broadcast memory

- 1 Press **[▶]**.
- 2 Press **[+]** or **[–]** repeatedly to display “**<BROADCAST>**”.
- 3 Press **[MENU]**.
- 4 Press **[⇄]**.
- 5 Press **[+]** or **[–]** repeatedly to display the desired item you want to erase.
 - To cancel erasing, press **[STOP]**.
- 6 Press **[SET]**.
- 7 Press **[SET]**.
 - To erase other items, repeat steps 5 to 7.
- 8 Press **[STOP]**.

5.4.4 Sending the same document to pre-programmed parties

- 1 Insert the document **FACE DOWN**.
- 2 If necessary, press **[+]** or **[–]** repeatedly to select the desired resolution (page 20).
- 3 Press **[BROADCAST]**.
 - The document will be fed into the unit and scanned into memory. The unit will then send the data to each party, calling each number sequentially.
 - After transmission, the stored document will be erased from memory automatically, and the unit will automatically print a report (**Broadcast sending report**).

Note:

- If you select “**FINE**”, “**SUPER FINE**” or “**PHOTO**” resolution, the number of pages that the unit can send will decrease.
- If the document exceeds the memory capacity, sending will be cancelled.
- If a party is busy or does not answer, it will be skipped and redialled later up to 5 times.

To send the same document to a one-time group of parties

You can also select a one-time group of parties to send the same document to. After transmission, this group will be deleted.

1. Insert the document.
2. Press **[▶]**.
3. Press **[+]** or **[-]** repeatedly to display “<ONE TIME BROAD>”.
4. Press **[SET]** to start programming the parties you want to send the document to.
5. Program items.

Using stations 1–5:

Press the desired station key.

Using stations 6–10:

Press **[LOWER]**, then press the desired station key.

Using phonebook:

Press **[+]** or **[-]** repeatedly to display the desired item and press **[SET]**.

- To program other items, repeat this step (up to 20 items).
 - If you program the wrong item, press **[STOP]** to erase the item.
6. Press **[FAX/START]** to start transmission to the programmed parties.

To cancel broadcast transmission

1. Press **[STOP]** repeatedly until “SEND CANCELLED?” is displayed.
2. Press **[SET]**.

Note:

- You can confirm the cancelled recipients on the Broadcast reports that will be printed after the cancellation is completed.

5.5 Selecting the way to use your fax machine

Depending on your situation, select the way you prefer to use your fax machine.

- Use as a telephone answering machine and/or fax (TAM/FAX mode) (KX-FT988 only)
- Use only as a fax (FAX ONLY mode)
- Use mostly as a telephone (TEL mode)
- Use as a telephone and/or fax (TEL/FAX mode)

5.5.1 Use as a telephone answering machine and/or fax (TAM/FAX mode) (KX-FT988 only)

Your situation

You want to answer phone calls using the telephone answering machine and receive faxes automatically.

Setup

Set the fax machine to TAM/FAX mode (page 25) by pressing **[AUTO ANSWER]** repeatedly.

- The **[AUTO ANSWER]** indicator turns ON.

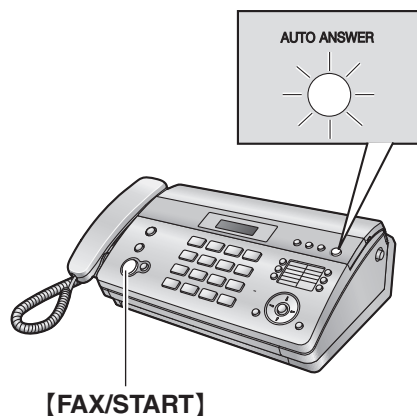

Note:

- Make sure feature #77 is set to “TAM/FAX” beforehand (page 35).
- Do not connect an answering machine to the same telephone line. If connected, set the automatic answer feature to OFF by pressing **[AUTO ANSWER]** repeatedly.

How phone calls and faxes are received

If the call is a phone call, the fax machine will record the caller's message automatically.

If a fax calling tone is detected, the fax machine will receive the fax automatically.

5.5.2 Use only as a fax (FAX ONLY mode)

Your situation

You have a separate telephone line just for faxes.

Setup

Set the fax machine to FAX ONLY mode (page 26) by pressing **[AUTO ANSWER]** repeatedly.

- The **[AUTO ANSWER]** indicator turns ON.

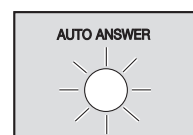

Note:

- Make sure feature #77 is set to “FAX ONLY” beforehand (page 35) (KX-FT988 only).

How faxes are received

All incoming calls will be answered as faxes.

5.5.3 Use mostly as a telephone (TEL mode)

Your situation

You want to answer calls by yourself. If a fax call is received, you must receive the fax manually.

5. Fax

Setup

Set the fax machine to TEL mode (page 24) by pressing **[AUTO ANSWER]** repeatedly.

- The **[AUTO ANSWER]** indicator turns OFF.

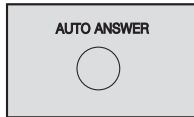

Note:

- Make sure feature #73 is set to “TEL” beforehand (page 35).

How to receive phone calls and faxes

You have to answer all calls manually.

To receive a fax, press **[FAX/START]**.

5.5.4 Use as a telephone and/or fax (TEL/FAX mode)

Your situation

You want to answer phone calls yourself and receive faxes automatically without rings.

Setup

Set the fax machine to TEL/FAX mode (page 25) by pressing **[AUTO ANSWER]** repeatedly.

- The **[AUTO ANSWER]** indicator turns OFF.

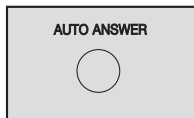

Note:

- Make sure feature #73 is set to “TEL/FAX” beforehand (page 35).

How phone calls and faxes are received

If the call is a phone call, the fax machine will ring.

If a fax calling tone is detected, the fax machine will receive the fax automatically without ringing.

5.6 Receiving a fax manually – Auto answer OFF

5.6.1 Activating TEL mode

- 1 Make sure feature #73 is set to “TEL” beforehand (page 35).
- 2 Press **[AUTO ANSWER]** repeatedly to display the following.

TEL MODE

- The **[AUTO ANSWER]** indicator turns OFF.

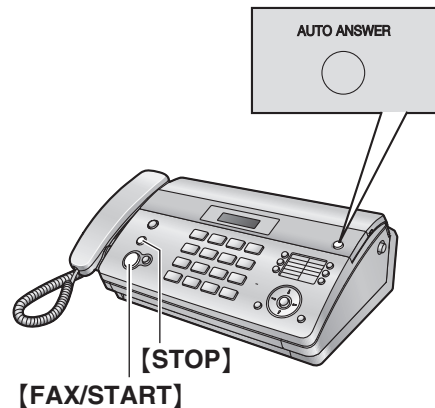

How to receive phone calls and faxes

1. Lift the handset to answer the call.
2. When:
 - document reception is required,
 - a fax calling tone (slow beep) is heard, or
 - no sound is heard,press **[FAX/START]**.

CONNECTING

- The unit will start fax reception.

3. Replace the handset.

Note:

- If you do not answer the call within 10 rings:

For KX-FT982:

The unit will temporarily switch to fax reception. The other party can then send a fax.

For KX-FT988:

If you do not answer the call within 10 rings, the unit will temporarily answer the call. Then you need to enter the remote operation ID to turn the auto answer setting ON. See page 31 for details.

How to receive phone calls and faxes with an extension telephone

If you have another telephone connected to the same line (extension telephone), you can use the extension telephone to receive faxes.

1. When the extension telephone rings, lift the handset of the extension telephone.
2. When:
 - document reception is required,
 - a fax calling tone (slow beep) is heard, or
 - no sound is heard,press **[*][#][9]** (default fax activation code) **firmly**.
 - The fax machine will start fax reception.
3. Replace the handset.

Note:

- To receive fax documents using the extension telephone, make sure remote fax activation is turned ON beforehand (feature #41 on page 34). The default setting is ON.

To stop receiving

Press **[STOP]**.

5.6.2 Activating TEL/FAX mode

- 1 Make sure feature #73 is set to “**TEL/FAX**” beforehand (page 35).
- 2 Press **[AUTO ANSWER]** repeatedly to display the following.

TEL/FAX MODE

- The **[AUTO ANSWER]** indicator turns OFF.

- 3 The ringer volume setting should be ON (page 11).

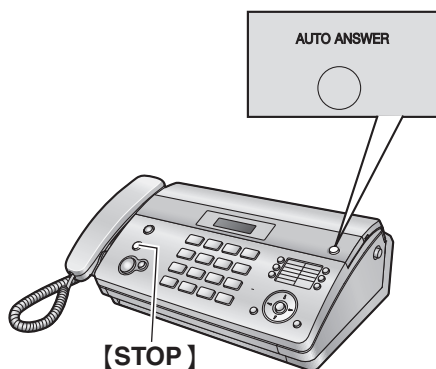
**How phone calls and faxes are received**

1. “**INCOMING CALL**” will be displayed but the unit will not ring.
2. The unit will wait for the duration of **2 rings** before answering the call.
 - The number of rings is determined by the “**TEL/FAX delayed ring setting**” (feature #78 on page 36).
 - During this time, an extension telephone will ring.
3. The unit will answer the call and try to detect a fax calling tone.

When a fax calling tone is detected

The unit receives the fax automatically without ringing.

When a fax calling tone is not detected

- 1 The unit will ring. You may answer the call.
 - Callers will hear a ring back tone different from the one generated by the telephone company.
 - An extension telephone will not ring at this time. To answer the call with the extension telephone (if connected to the same line), lift the handset and press **[*] [0]** (default auto disconnection code)

while the fax machine is ringing. The auto disconnection code can be changed in feature #49 on page 35.

- 2 If you do not answer the call, the unit will activate the fax function.
 - Some fax machines do not generate fax calling tones when sending faxes, therefore the unit will try to receive a fax even if no fax calling tone is detected.

Note:

- If you answer a call with the extension telephone, the fax machine may activate the fax function depending on the type of an extension telephone. Press **[STOP]** on the fax machine to talk with the calling party.

5.7 Receiving a fax automatically – Auto answer ON**5.7.1 Activating TAM/FAX mode (KX-FT988 only)**

- 1 Make sure feature #77 is set to “**TAM/FAX**” beforehand (page 35).
- 2 Press **[AUTO ANSWER]** repeatedly to display the following.

TAM/FAX MODE

- The **[AUTO ANSWER]** indicator turns ON.
- The unit will play the pre-recorded greeting message. You can record your own greeting message (page 29).
- The remaining time for recording incoming messages will be displayed.

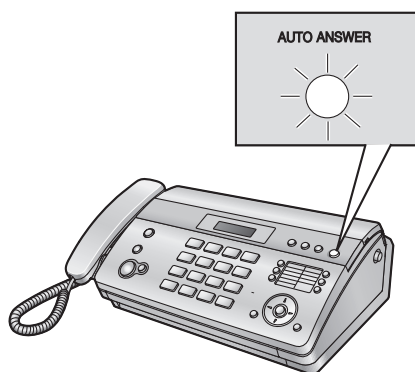
**Note:**

- The maximum recording time for incoming message can be changed (feature #10 on page 33).
- While an incoming call is being recorded, you can monitor it through the speaker. If this feature is not required, turn OFF feature #67 (page 35).
- If the unit announces the memory is full, erase unnecessary messages (page 30).

5. Fax

How phone calls and faxes are received

When receiving calls, the unit works as an answering machine and/or fax.

- If the call is a phone call, the unit will record the caller's message automatically.
- If a fax calling tone is detected, the unit will receive the fax automatically.

Receiving a voice message and fax document in one call

The caller can leave a voice message and send a fax document during the same call. Inform the caller of the following procedure beforehand.

1. The caller calls your unit.
 - The answering machine will answer the call.
2. The caller can leave a message after the greeting message.
3. The caller presses **[*][9]**.
 - The unit will activate the fax function.
4. The caller presses the start button to send a fax.

Ring setting in TAM/FAX mode

You can change the number of rings before the unit answers calls. You can choose from "2" (default), "3", "4", "5", "6", "7" and "TOLL SAVER". This setting can be changed by feature #06 on page 33.

"TOLL SAVER": The unit answers after 2 or 3 rings when new messages have been recorded, and after 5 or 6 rings when there are no new messages. If you call your unit from outside to listen to new messages (page 31), you will know that there are no messages when the unit rings for the 4th time. You can then hang up without being charged for the call.

5.7.2 Activating FAX ONLY mode

- 1 Make sure feature #77 is set to "FAX ONLY" beforehand (page 35) (KX-FT988 only).
- 2 Press **[AUTO ANSWER]** repeatedly to display the following.

FAX ONLY MODE

- The **[AUTO ANSWER]** indicator turns ON.

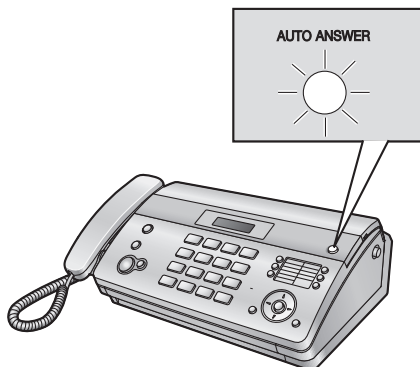

How faxes are received

When receiving calls, the unit will automatically answer all calls and only receive fax documents.

Note:

- The number of rings before a call is answered in FAX ONLY mode can be changed (feature #06 on page 32).

5.8 Receive polling

This feature allows you to retrieve a document by calling an available polling service. Therefore you pay for the call. Make sure that no documents are fed into your unit.

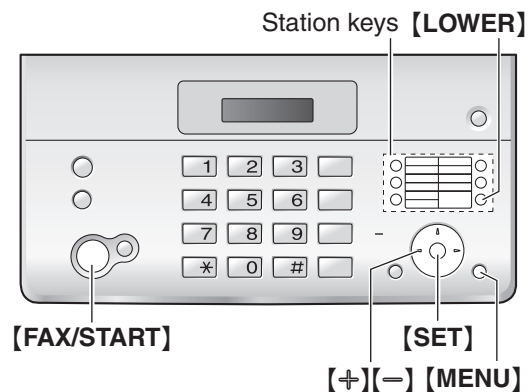

- 1 Press **[MENU]** repeatedly to display "POLLING".
- 2 Press **[SET]**.
- 3 Dial the fax number.

Using dial keys ([0] to [9], [*] or [#]):
Enter the fax number.

Using one-touch dial:

For stations 1–5

Press the desired station key.

For stations 6–10

Press **[LOWER]**, then press the desired station key.

Using phonebook:

Press **[+]** or **[–]** repeatedly to display the desired item.

- 4 Press **[FAX/START]**.
 - The unit will start fax reception.

5.9 Junk fax prohibitor (preventing fax reception from undesired callers)

If you subscribe to Caller ID service (page 16), this feature prevents fax reception from calls that do not show caller information.

Additionally, the fax machine will not accept faxes originated from numbers that match the one on a programmable junk fax prohibitor list.

Important:

- This feature does not work when manual reception is performed.

5.9.1 Activating the junk fax prohibitor

1. Press **[MENU]** repeatedly to display “JUNK FAX PROH.”.
2. Press **[▶]**.
3. Press **[+]** or **[-]** repeatedly to select “ON”.
4. Press **[SET]**.
5. Press **[MENU]** to exit.

5.9.2 Storing undesired callers

You can register up to 10 undesired numbers from the Caller ID list (page 16) if you do not wish to receive faxes from them.

1. Press **[MENU]** repeatedly to display “JUNK FAX PROH.”.
2. Press **[▶]** repeatedly to display “JUNK LIST SET”.
3. Press **[SET]**.
4. Press **[+]** or **[-]** repeatedly to display the item you wish to prevent the fax reception from.
5. Press **[SET]**.
6. Press **[STOP]** to exit.

To display the junk fax prohibitor list

1. Press **[MENU]** repeatedly to display “JUNK FAX PROH.”.
2. Press **[▶]** repeatedly to display “JUNK LIST DISP.”.
3. Press **[SET]**.
4. Press **[+]** or **[-]** to display the item.
5. Press **[MENU]** to exit.

To print the junk fax prohibitor list

1. Press **[MENU]** repeatedly to display “JUNK FAX PROH.”.
2. Press **[▶]** repeatedly to display “JUNK LIST PRINT”.
3. Press **[SET]**.
4. Press **[MENU]** to exit.

To erase an item from the junk fax prohibitor list

1. Press **[MENU]** repeatedly to display “JUNK FAX PROH.”.
2. Press **[▶]** repeatedly to display “JUNK LIST DISP.”.
3. Press **[SET]**.
4. Press **[+]** or **[-]** repeatedly to display the desired item.
5. Press **[◀]**.
 - To cancel erasing, press **[STOP]**, then press **[MENU]**.
6. Press **[SET]**.
7. Press **[MENU]**.

6. Copy

6.1 Making a copy

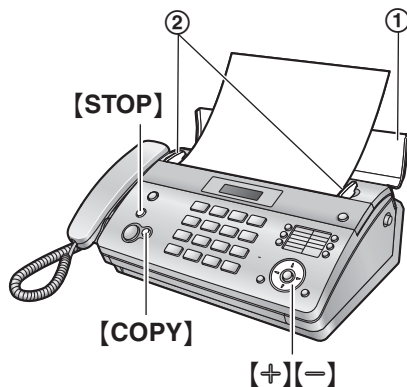

- 1 Open the document feeder tray (①), then adjust the width of the document guides (②) to fit the actual size of the document.
- 2 Insert the document (up to 10 pages) **FACE DOWN** until a single beep is heard and the unit grasps the document.
 - If the document guides are not adjusted to fit the document, re-adjust them.
- 3 If necessary, press **[+]** or **[-]** repeatedly to select the desired resolution.
- 4 Press **[COPY]**.
 - The unit will start copying.

Note:

- When you copy a multiple-page document which is longer than A4 size paper (approx. 300 mm), we recommend you insert one page at a time.
- Any document which can be sent as a fax can also be copied (page 20).
- The copied recording paper comes out somewhat longer than the document size.

To select the resolution

Select the desired resolution according to the type of document.

- “**FINE**”: For printed or typewritten documents with small print.
- “**SUPER FINE**”: For documents with very small print.
- “**PHOTO**”: For documents containing photographs, shaded drawings, etc.
- If you select “**STANDARD**”, copying will be done using “**FINE**” mode.

To stop copying

Press **[STOP]**.

7.1 Recording your greeting message

You can record your own greeting message for TAM/FAX mode, for a maximum of 16 (default) or 60 seconds in length. We recommend you record a message of less than 12 seconds to make it easier to receive faxes.

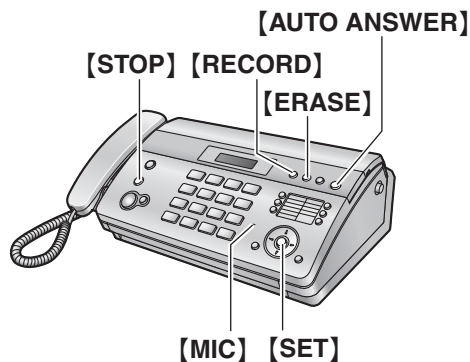

- 1 Set feature #77 to “**TAM/FAX**” beforehand (page 35).
- 2 Press **[RECORD]**.
- 3 Press **[SET]**.
 - A long beep will sound.
- 4 Speak clearly about 20 cm away from **[MIC]**.
 - The display will show the remaining recording time.
- 5 To stop recording, press **[STOP]**.
 - The unit will repeat your message.

Note:

- You can change the maximum TAM/FAX greeting message recording time to 60 seconds (feature #54 on page 35).
 - If you change the setting to 60 seconds, we recommend that you tell the caller in your TAM/FAX greeting message to press **[*][9]** before starting fax transmission.
 - If you change the setting from 60 seconds to 16 seconds, your greeting message will be deleted. The pre-recorded greeting message will be played when a call is received.

To check the greeting message

1. Make sure feature #77 is set to “**TAM/FAX**” beforehand (page 35).
2. Press **[AUTO ANSWER]** repeatedly to display “**TAM/FAX MODE**”.
 - The unit will play the TAM/FAX greeting message.

7.1.1 Erasing your recorded greeting message

- 1 Set feature #77 to “**TAM/FAX**” beforehand (page 35).
- 2 Press **[ERASE]** 2 times.
- 3 Press **[SET]**.
 - To cancel erasing, press **[STOP]**.
- 4 Press **[SET]**.

Note:

- If you erase your TAM/FAX greeting message, the pre-recorded greeting message will be played when a call is received.

7.2 Leaving a message for others or yourself

To leave a private message for yourself or someone else, you can record a voice memo. This memo can be played back later, either directly or remotely.

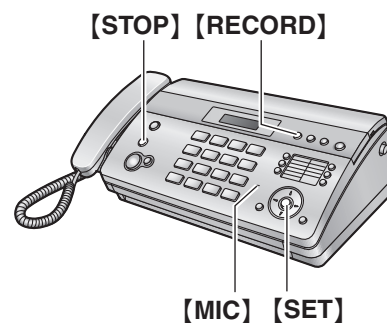

- 1 Press **[RECORD]** 2 times.
- 2 Press **[SET]**.
 - A long beep will sound.
- 3 Speak clearly about 20 cm away from **[MIC]**.
- 4 To stop recording, press **[STOP]**.

7.3 Listening to recorded messages

When the unit has recorded new voice messages:

- The **[AUTO ANSWER]** indicator will flash when the auto answer setting is turned ON.
- The total number of recorded messages will flash on the display.

7. Answering Machine (KX-FT988 only)

Example:

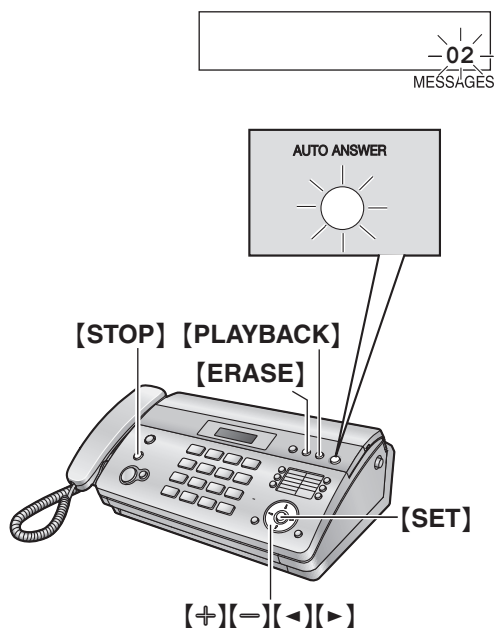

Press **[PLAYBACK]**.

- Only new messages will be played.
- Adjust the speaker volume using **[+]** or **[-]**.
- After playing back all of the new messages;
 - the **[AUTO ANSWER]** indicator will stop flashing but will remain lit up when the auto answer setting is turned ON.
 - the total number of recorded messages will stop flashing and remain displayed.If you press **[PLAYBACK]** at this time, all recorded messages will be played.

Note:

- The total recording time of all messages (greeting and incoming) is **about 12 minutes**. A maximum of 59 messages can be recorded. If messages are recorded in noisy environment, the actual recording time may be less.

To repeat a message

Press **[◀]** while listening to the message.

- If you press **[◀]** within 5 seconds of the beginning of the message, the previous message will be played.
- To play back a specific message, press **[◀]** or **[▶]** and search for the message you want to listen to.

To skip a message

Press **[▶]** to play the next message.

To stop playback

Press **[STOP]** 2 times.

7.3.1 Erasing recorded messages

To erase a specific message

Press **[ERASE]** while listening to the message you want to erase.

To erase all messages

- 1 Press **[ERASE]** while the unit is idle.
- 2 Press **[SET]**.
 - To cancel erasing, press **[STOP]**.
- 3 Press **[SET]**.

7.4 Operating from a remote location

Important:

- Program the remote operation ID beforehand (feature #11 on page 33).
- Set the unit to TAM/FAX mode before going out (page 25).
- Use a touch tone telephone for remote operations.

7.4.1 Summary of remote operation

- 1 Call your unit.
- 2 Enter the remote operation ID during or after the TAM/FAX greeting message.
- 3 **When there are new recorded messages**
 1. A long beep will sound.
 2. Short beep(s) will sound up to 8 times.
 - This indicates the number of new messages.
 3. New messages will be played back.

When there are no new messages

1. A long beep will sound (short beep will not sound).
2. Wait for 4 seconds or press **[5]**.
3. All the recorded messages will be played back.
- 4 To end remote operation press **[9]**, then hang up.

Note:

- When the voice memory is full, 6 beeps will sound after playing back the recorded messages. Erase any unnecessary messages.

7.4.2 Remote operation using remote commands

- 1 Call your unit.
- 2 Enter the remote operation ID during or after the TAM/FAX greeting message.
- 3 Enter a remote command within 10 seconds.

Note:

- When you press a key, press firmly.

Key	Remote command
[1]	Repeats a message (during playback) ^{*1}
[2]	Skips a message (during playback)
[4]	Plays new messages
[5]	Plays all messages
[6]	Room monitor
[7]	Records greeting message
[9]	Stops current operation ^{*2}
[0]	Turns OFF auto answer setting
[*][4]	Erases a specific message (during playback)
[*][5]	Erases all messages
[#]	Skips the greeting message

*1 If pressed within the first 5 seconds of a message, the previous message will be played.

*2 To resume operation, press a command key within 10 seconds, otherwise the marker message recording will start.

Recording a marker message

After playing back messages, you can leave an additional message.

1. Wait for 3 beeps indicating the end of the remote operation.
2. Hear 1 beep.
3. Wait about 10 seconds.
4. Hear the voice guide and/or hear 1 beep.
5. Leave a message.

To turn ON the auto answer setting

1. Call your unit and wait for 10 rings.
 - A beep will sound.
2. Enter the remote operation ID (feature #11 on page 33) within 8 seconds.
 - The unit will play the greeting message, and the auto answer setting will be turned ON. The receiving mode will be set to TAM/FAX.
3. Hang up the handset.

Note:

You cannot turn ON the auto answer setting when the unit is set to TEL/FAX mode.

Monitoring the room

Press **[6]** to monitor the sound for about 30 seconds in the room where the unit is installed.

- After 30 seconds, a beep will sound. To continue monitoring, press **[6]** again within 10 seconds.

8. Programmable Features

8.1 Programming



[+][-][<][>] [SET] [MENU]

8.1.1 Programming basic features

- 1 Press **[MENU]**.
- 2 Select the feature you wish to program.
Press **[<]** or **[>]** repeatedly to display the desired feature.
 - The current setting of the feature will be displayed.
- 3 Press **[+]** or **[-]** repeatedly to display the desired setting.
 - This step may be slightly different depending on the feature.
- 4 Press **[SET]**.
 - The setting you selected is set, and the next feature will be displayed.
- 5 To exit programming, press **[MENU]**.

8.1.2 Programming advanced features

- 1 Press **[MENU]**.
- 2 Press **[<]** or **[>]** repeatedly to display "ADVANCE SETTINGS".
- 3 Press **[SET]**.
- 4 Select the feature you wish to program.
Press **[<]** or **[>]** repeatedly to display the desired feature.
 - The current setting of the feature will be displayed.
- 5 Press **[+]** or **[-]** repeatedly to display the desired setting.
 - This step may be slightly different depending on the feature.
- 6 Press **[SET]**.
 - The setting you selected is set, and the next feature will be displayed.
- 7 To exit programming, press **[MENU]**.

To program by entering the program code number directly

You can select a feature by directly entering its program code (# and a 2-digit number) instead of using **[<]** or **[>]**.

1. Press **[MENU]**.
2. Press **[#]** and the 2-digit code (page 32 to page 36).
3. Press **[+]** or **[-]** repeatedly to display the desired setting.
 - This step may be slightly different depending on the feature.
4. Press **[SET]**.
5. To exit programming, press **[MENU]**.

To cancel programming

Press **[MENU]** to exit.

8.2 Basic features

Code #01: Setting the date and time

```
SET DATE & TIME
PRESS SET
```

See page 11 for details.

Code #02: Setting your logo

```
YOUR LOGO
PRESS SET
```

See page 12 for details.

Code #03: Setting your fax number

```
YOUR FAX NO.
PRESS SET
```

See page 13 for details.

Code #04: Printing a sending report

```
SENDING REPORT
=ERROR [±]
```

To print a sending report for fax transmission results (page 20).

"ERROR" (default): A sending report will be printed only when fax transmission fails.

"ON": A sending report will be printed after every transmission.

"OFF": The sending reports will not be printed.

Code #06: Changing the ring setting in FAX ONLY mode

```
FAX RING COUNT
RINGS=2 [±]
```

To change the number of rings before the unit answers a call in FAX ONLY mode.

You can select “1”, “2” (default), “3”, “4”, “5”, “6”, “7”, “8” or “9”.

Note:

- Set feature #77 to “**FAX ONLY**” beforehand (page 35).

Code #06: Changing the ring setting in TAM/FAX mode (KX-FT988 only)

TAM RING COUNT RINGS=2 [±]

To change the number of rings before the unit answers a call in TAM/FAX mode. You can select “2” (default), “3”, “4”, “5”, “6”, “7” or “**TOLL SAVER**”. See page 26 for details.

Note:

- Set feature #77 to “**TAM/FAX**” beforehand (page 35).

Code #10: Changing the maximum recording time for incoming messages (KX-FT988 only)

RECORDING TIME =3 MINUTES [±]

“**GREETING ONLY**”: The unit plays the greeting message but does not record any incoming messages.

“1 MINUTE”: 1 minute

“2 MINUTES”: 2 minutes

“3 MINUTES” (default): 3 minutes

Code #11: Setting the remote operation ID (KX-FT988 only)

REMOTE TAM ID ID=____

A 3-digit remote operation ID must be entered when operating the answering system remotely. This ID prevents unauthorised parties from listening to your messages remotely. After you store your remote operation ID, remote operation is possible.

1. Press **[MENU]**.
2. Press **[⇄]**, then **[1][1]**.
3. To activate the remote operation feature, enter a 3-digit remote operation ID.
 - To deactivate the remote operation feature, press **[*]**.
4. Press **[SET]**.
5. Press **[MENU]**.

Code #13: Setting the dialling mode

DIAL MODE =TONE [±]

See page 11 for details.

Code #17: Setting the ringer tone

RINGER TONE =TONE 1 [±]

To set the ringer tone from one of 3 patterns for outside calls. You can select “**TONE 1**” (default), “**TONE 2**” or “**TONE 3**”.

8.3 Advanced features

See page 32 for how to enter advanced feature programming.

Code #22: Setting the journal report to print automatically

AUTO JOURNAL =ON [±]

“**ON**” (default): The unit will print a journal report automatically after every 30 new fax transmissions and receptions (page 20).

“**OFF**”: The unit will not print a journal report, but will keep a record of the last 30 fax transmissions and receptions.

Code #23: Sending documents overseas

OVERSEAS MODE =ERROR [±]

If you cannot send a fax overseas even if the number is correct and the line is connected, activate this feature before sending the fax.

This feature improves the reliability by reducing the transmission speed.

“**ERROR**” (default): When the previous fax transmission fails and you wish to re-send the document.

“**NEXT FAX**”: This setting is effective only for the next attempted fax transmission. After transmission, the unit will return to the previous setting.

“**OFF**”: Deactivates this feature.

Note:

- This feature is not available for broadcast transmission.
- Calling charges may be higher than usual.

Code #25: Sending a fax at a specific time

DELAYED SEND =OFF [±]

This feature allows you to take advantage of low-cost calling hours offered by your telephone company. This feature can be set up to 24 hours in advance of the desired time.

To send a document:

1. Insert the document.
2. If necessary, press **[+]** or **[-]** repeatedly to select the desired resolution (page 20).
3. Press **[MENU]**.
4. Press **[⇄]** then **[2][5]**.
5. Press **[+]** or **[-]** repeatedly to select “**ON**”.
6. Press **[SET]**.
7. Enter the fax number. (page 21)

8. Programmable Features

8. Press **[SET]**.
 9. Enter the transmission start time.
 - If you select 12-hour time entry when you set the date and time (page 11), press **[*]** repeatedly to select **"AM"** or **"PM"**.
 - If you selected 24-hour time entry when you set the date and time (page 11), the time is set using 24-hour time entry.
 10. Press **[SET]**.
 11. Press **[MENU]**.
- Note:**
- To cancel after programming, press **[STOP]** then **[SET]**.

Code #26: Setting the Caller ID list to print automatically

AUTO CALL. LIST =OFF [±]

"ON": The Caller ID list will be printed automatically each time the unit logs 30 different callers (page 16).
"OFF" (default): The Caller ID list will not be printed, but the unit will keep a record of the information for the last 30 different callers.

Code #36: Receiving oversized documents

RCV REDUCTION =ON [±]

To slightly reduce the received fax image when printing, so that the received document will be approximately the same length as the original document.
"ON" (default): The received fax image will be printed slightly smaller than the original image.
"OFF": Deactivates this feature. The received fax image will be printed at the same size as the original image.

Note:

- A slight margin will be added to the printed documents, and therefore if this feature is turned OFF, the received document will be slightly longer than the original document.

Code #39: Changing the display contrast

LCD CONTRAST =NORMAL [±]

"NORMAL" (default): For normal contrast.
"DARKER": Used when the display contrast is too light.

Code #41: Changing the fax activation code

FAX ACTIVATION =ON [±]

If you wish to use an extension telephone (page 24) to receive faxes, activate this feature and program the activation code.

1. Press **[MENU]**.
2. Press **[#]**, then **[4][1]**.
3. Press **[+]** or **[-]** repeatedly to select **"ON"**.

4. Press **[SET]**.
5. Enter your code (2 to 4 digits) using the dial keys **[0]–[9]**, **[*]** and **[#]**.
 - The default code is **"*#9"**.
6. Press **[SET]**.
7. Press **[MENU]**.

Code #44: Setting the memory reception alert

RECEIVE ALERT =ON [±]

To alert you with a beeping sound when a received fax document is stored into memory due to some existing problem.

The slow beeps will continue until you clear the printing problem and make sure the unit is supplied with enough paper to print the stored document.

"ON" (default): You will be alerted to a reception problem by a beeping sound.

"OFF": Deactivates this feature.

Code #46: Setting friendly reception

FRIENDLY RCV =ON [±]

To receive a fax automatically when you answer a call and hear a fax calling tone (slow beep).

"ON" (default): You do not have to press **[FAX/START]** for fax reception.

"OFF": You have to press **[FAX/START]** for fax reception.

Code #47: Setting the voice guidance (KX-FT988 only)

VOICE GUIDANCE =ON [±]

If you wish to hear voice guidance, activate this feature.

"ON" (default): You will hear the friendly reception voice guide, pre-recorded messages and voice time/day stamp.

"OFF": Deactivates this feature.

Code #48: Selecting the language

LANGUAGE =ENGLISH [±]

The display and reports will be in the selected language.

"ENGLISH" (default): English is used.

"CZECH": Czech is used.

"SLOVAK": Slovak is used.

1. Press **[MENU]**.
2. Press **[#]**, then **[4][8]**.
3. Press **[+]** or **[-]** repeatedly to select the desired language.
4. Press **[SET]**.
5. Press **[MENU]**.

Code #49: Setting the auto disconnection

AUTO DISCONNECT	
=ON	[±]

To answer a call with an extension telephone in TEL/FAX mode (page 25), activate this feature and program the code.

1. Press **[MENU]**.
2. Press **[#]**, then **[4][9]**.
3. Press **[+]** or **[-]** repeatedly to select "ON".
4. Press **[SET]**.
5. Enter your code from 2 to 4 digits, using 0-9 and **[*]**.
 - The default code is "*0"
6. Press **[SET]**.
7. Press **[MENU]**.

Code #54: Changing the recording time for your TAM/FAX greeting message (KX-FT988 only)

GREETING TIME	
=16s	[±]

"16s" (default): Maximum recording time is 16 seconds.
 "60s": Maximum recording time is 60 seconds.
 See page 29 for details.

Code #58: Setting the scan contrast

SCAN CONTRAST	
=NORMAL	[±]

To send or copy a document with faint or dark writing, set this feature before starting transmission or copying.

"NORMAL" (default): Used for normal writing.

"LIGHT": Used for dark writing.

"DARKER": Used for faint writing.

- This feature is not valid if you select "PHOTO" resolution for sending (page 20) or copying (page 28) a document.

Code #59: Setting the print contrast

PRINT CONTRAST	
=NORMAL	[±]

To adjust the darkness of received or copied documents.

"NORMAL" (default): Normal contrast.

"DARKER": Darker contrast.

Code #67: Setting the incoming message monitor (KX-FT988 only)

ICM MONITOR	
=ON	[±]

To hear an incoming message (ICM) from the speaker when the answering device is recording the message.

"ON" (default): You can monitor the incoming message.

"OFF": Deactivates this feature.

Code #72: Setting recall/flash time

SET FLASH TIME	
=600ms	[±]

The recall/flash time depends on your telephone exchange or host PBX. You can select "900ms", "700ms", "600ms" (default), "400ms", "300ms", "250ms", "200ms", "160ms", "110ms", "100ms", "90ms" or "80ms".

Note:

- If the unit is connected via a PBX, this setting may need to be changed in order for PBX functions (transferring a call, etc.) to work correctly. Consult your PBX supplier for the correct setting.
- If you set the location setting to "CZECH" or "SLOVAKIA" (feature #74 on page 35), the default setting will be "100ms".

Code #73: Changing the receiving mode in the manual answer setting

MANUAL ANSWER	
=TEL	[±]

"TEL" (default): Telephone mode (page 24)

"TEL/FAX": Telephone/Fax mode (page 25)

Code #74: Setting the location where you use this unit

LOCATION	
=EAST EUROPE	[±]

This setting must match your location.

"EAST EUROPE" (default): To use in East Europe countries.

"CZECH": To use in Czech Republic.

"SLOVAKIA": To use in Slovakia.

Code #76: Setting the connecting tone

CONNECTING TONE	
=ON	[±]

If you often have trouble when sending faxes, this feature allows you to hear connecting tones: fax tone, ring back tone and busy tone. You can use these tones to confirm the status of the other party's machine.

"ON" (default): You will hear connecting tones.

"OFF": Deactivates this feature.

Note:

- If the ring back tone continues, the other party's machine may not be a fax machine or may have run out of paper. Check with the other party.
- The connecting tone volume cannot be adjusted.

Code #77: Changing the receiving mode in the auto answer setting (KX-FT988 only)

AUTO ANSWER	
=TAM/FAX	[±]

"TAM/FAX" (default): Telephone Answering Machine/Fax mode (page 25)

8. Programmable Features

“FAX ONLY”: FAX only mode (page 26)

Code #78: Changing the TEL/FAX delayed ring setting

```
TEL/FAX RING
RINGS=2      [±]
```

If you use an extension telephone in TEL/FAX mode, select the desired number of times the extension telephone rings before the unit answers the call. You can select “1”, “2” (default), “3”, “4”, “5”, “6”, “7”, “8” or “9”. See page 25 for details.

Code #80: Resetting advanced features to their default settings

```
SET DEFAULT
RESET=NO     [±]
```

To reset the advanced features:

1. Press **[MENU]**.
2. Press **[#]**, then **[8][0]**.
3. Press **[+]** or **[-]** repeatedly to select “YES”.
4. Press **[SET]**.
5. Press **[SET]** again.
6. Press **[MENU]**.
 - Language selection (feature #48, page 34) and the location setting (feature #74 on page 35) will not be reset.

8.4 Direct commands for programming features

You can also select the desired setting by directly entering the program code (# and a 2-digit number) and direct command.

For more details on the features, see page 32 to page 36.

- 1 Press **[MENU]**.
- 2 Press **[#]** and the 2-digit code number.
- 3 Press the desired direct command to display the desired setting.
 - This step may be slightly different depending on the feature.
- 4 Press **[SET]**.
- 5 To exit programming, press **[MENU]**.

8.4.1 Program code and direct command button

[#][0][1] Date and time

- Enter the date and time using the dial keypad. See page 11 for details.

[#][0][2] Your logo

- Enter your logo using the dial keypad. See page 12 for details.

[#][0][3] Your fax number

- Enter your fax number using the dial keypad. See page 13 for details.

[#][0][4] Sending report

- **[0]**: “OFF”
- **[1]**: “ON”
- **[2]**: “ERROR” (default)

[#][0][6] FAX ring count

- **[1]**: “1”
- **[2]**: “2” (default)
- **[3]**: “3”
- **[4]**: “4”
- **[5]**: “5”
- **[6]**: “6”
- **[7]**: “7”
- **[8]**: “8”
- **[9]**: “9”

[#][0][6] TAM ring count (KX-FT988 only)

- **[0]**: “TOLL SAVER”
- **[2]**: “2” (default)
- **[3]**: “3”
- **[4]**: “4”
- **[5]**: “5”
- **[6]**: “6”
- **[7]**: “7”

[#][1][0] Message recording time (KX-FT988 only)

- **[0]**: “GREETING ONLY”
- **[1]**: “1 MINUTE”
- **[2]**: “2 MINUTES”
- **[3]**: “3 MINUTES” (default)

[#][1][1] Remote operation ID (KX-FT988 only)

- Enter a 3-digit number to activate the remote operation feature. To deactivate the remote operation feature, press **[*]**.

[#][1][3] Dialling mode

- **[1]**: “PULSE”
- **[2]**: “TONE” (default)

[#][1][7] Ringer tone

- **[1]**: “TONE 1” (default)
- **[2]**: “TONE 2”
- **[3]**: “TONE 3”

[#][2][2] Automatic journal report

- **[0]**: “OFF”
- **[1]**: “ON” (default)

[#][2][3] Overseas mode

- **[0]**: “OFF”
- **[1]**: “NEXT FAX”
- **[2]**: “ERROR” (default)

[*][2][5] Delayed transmission

- [0]: "OFF" (default)
- [1]: "ON"
- If you select "ON", next enter the fax number and transmission time using the dial keypad (see feature #25 on page 33 for details).

[*][2][6] Automatic Caller ID list

- [0]: "OFF" (default)
- [1]: "ON"

[*][3][6] Receiving reduction

- [0]: "OFF"
- [1]: "ON" (default)

[*][3][9] Display contrast

- [1]: "NORMAL" (default)
- [2]: "DARKER"

[*][4][1] Fax activation code

- [0]: "OFF"
- [1]: "ON" (default)
- If you select "ON", next enter your 2 to 4 digit code using [0]–[9], [*] and [#].

[*][4][4] Memory reception alert

- [0]: "OFF"
- [1]: "ON" (default)

[*][4][6] Friendly reception

- [0]: "OFF"
- [1]: "ON" (default)

[*][4][7] Voice guidance (KX-FT988 only)

- [0]: "OFF"
- [1]: "ON" (default)

[*][4][8] Language

- [1]: "ENGLISH" (default)
- [2]: "CZECH"
- [3]: "SLOVAK"

[*][4][9] Auto disconnection

- [0]: "OFF"
- [1]: "ON" (default)

[*][5][4] Greeting recording time (KX-FT988 only)

- [1]: "16s" (default)
- [2]: "60s"

[*][5][8] Scan contrast

- [1]: "NORMAL" (default)
- [2]: "LIGHT"
- [3]: "DARKER"

[*][5][9] Print contrast

- [1]: "NORMAL" (default)
- [2]: "DARKER"

[*][6][7] Incoming message monitor (KX-FT988 only)

- [0]: "OFF"
- [1]: "ON" (default)

[*][7][2] Recall/flash time

- [1]: "900ms"
- [2]: "700ms"
- [3]: "600ms" (default for EAST EUROPE)
- [4]: "400ms"
- [5]: "300ms"
- [6]: "250ms"
- [7]: "200ms"
- [8]: "160ms"
- [9]: "110ms"
- [*]: "100ms" (default for CZECH and SLOVAKIA)
- [0]: "90ms"
- [#]: "80ms"

[*][7][3] Manual receive mode

- [1]: "TEL" (default)
- [2]: "TEL/FAX"

[*][7][4] Location

- [1]: "EAST EUROPE" (default)
- [2]: "CZECH"
- [3]: "SLOVAKIA"

[*][7][6] Connecting tone

- [0]: "OFF"
- [1]: "ON" (default)

[*][7][7] Auto answer (KX-FT988 only)

- [1]: "TAM/FAX" (default)
- [2]: "FAX ONLY"

[*][7][8] TEL/FAX ring setting

- [1]: "1"
- [2]: "2" (default)
- [3]: "3"
- [4]: "4"
- [5]: "5"
- [6]: "6"
- [7]: "7"
- [8]: "8"
- [9]: "9"

[*][8][0] Set default

- [0]: "NO" (default)
- [1]: "YES"

9.1 Error messages – Reports

If a problem occurs during fax transmission or reception, one of the following messages will be printed on the sending and journal reports (page 20).

Message	Code	Cause & Solution
COMMUNICATION ERROR	40-42 46-72 FF	<ul style="list-style-type: none"> • A transmission or reception error occurred. Try again or check with the other party.
	43 44	<ul style="list-style-type: none"> • A line problem occurred. Connect the telephone line cord to a different jack and try again. • An overseas transmission error occurred. Try using the overseas mode (feature #23 on page 33).
DOCUMENT JAMMED	----	<ul style="list-style-type: none"> • The document is jammed. Remove the jammed document (page 44).
ERROR-NOT YOUR UNIT	53 54 59 70	<ul style="list-style-type: none"> • A transmission or reception error occurred because of a problem with the other party's fax machine. Check with the other party.
JUNK FAX PROH. REJECT	----	<ul style="list-style-type: none"> • The junk fax prohibitor feature of this unit rejected fax reception.
MEMORY FULL	----	<ul style="list-style-type: none"> • The memory is full of received documents due to a lack of recording paper or a recording paper jam. Install paper (page 5) or clear the jammed paper (page 44).
NO DOCUMENT	----	<ul style="list-style-type: none"> • The document was not fed into the unit properly. Re-insert it and try again.
OTHER FAX NOT RESPONDING	----	<ul style="list-style-type: none"> • The other party's fax machine is busy or has run out of recording paper. Try again. • The other party's fax machine rings too many times. Send the fax manually (page 20). • The other party's machine is not a fax machine. Check with the other party. • The number you dialled is not in service.
PRESSED THE STOP KEY	----	<ul style="list-style-type: none"> • [STOP] was pressed, and fax transmission or reception was cancelled.
OK	----	<ul style="list-style-type: none"> • Fax transmission or reception was successful.

9.2 Error messages – Display

If the unit detects a problem, one or more of the following messages will appear on the display.

Display	Cause & Solution
"CALL SERVICE"	<ul style="list-style-type: none"> • There is something wrong with the unit. Contact our service personnel.
"CHECK DOCUMENT"	<ul style="list-style-type: none"> • The document was not fed into the unit properly. Re-insert the document. If misfeeding occurs frequently, clean the document feeder rollers (page 45) and try again. • Attempted to send a document longer than 600 mm. Press [STOP] to remove the document. Divide the document into two or more sheets and try again.

Display	Cause & Solution
“COVER OPEN” “CHECK PAPER”	<ul style="list-style-type: none"> ● The cover is open. Close it and press [FAX/START] to clear the message. ● The unit has run out of recording paper. Install recording paper (page 5) and press [FAX/START] to clear the message.
“FAX IN MEMORY”	<ul style="list-style-type: none"> ● The unit has a document in memory. See the other displayed message instructions to print out the document. For fax memory capacity, see page 47.
“FAX MEMORY FULL”	<ul style="list-style-type: none"> ● The memory is full of received documents due to a lack of recording paper or a recording paper jam. Install paper (page 5) or clear the jammed paper (page 44). ● When performing broadcast transmission, the document being stored exceeded the memory capacity of the unit. Send the entire document manually.
“PHONEBOOK FULL”	<ul style="list-style-type: none"> ● There is no space to store new items in the phonebook. Erase unnecessary items (page 14).
“MESSAGE FULL”	<ul style="list-style-type: none"> ● There is no memory available to record voice messages. Erase unnecessary messages (page 30).
“MODEM ERROR”	<ul style="list-style-type: none"> ● There is something wrong with the unit’s modem. Contact our service personnel.
“NO FAX REPLY”	<ul style="list-style-type: none"> ● The other party’s fax machine is busy or has run out of recording paper. Try again.
“PAPER JAMMED” “CHECK STACKER” ^{*1}	<ul style="list-style-type: none"> ● A recording paper jam occurred. Clear the jammed paper (page 44). *1 Make sure the paper stacker is inserted (page 4) (KX-FT988 only).
“PLEASE WAIT”	<ul style="list-style-type: none"> ● The unit is checking and initializing the paper. Wait for a moment while the check is completed.
“POLLING ERROR”	<ul style="list-style-type: none"> ● The other party’s fax machine does not support polling. Check with the other party.
“REDIAL TIME OUT”	<ul style="list-style-type: none"> ● The other party’s fax machine is busy or has run out of recording paper. Try again.
“REMOVE DOCUMENT”	<ul style="list-style-type: none"> ● The document is jammed. Remove the jammed document (page 44). ● Press [STOP] to eject the jammed document.
“TRANSMIT ERROR”	<ul style="list-style-type: none"> ● A transmission error occurred. Try again.
“UNIT OVERHEATED”	<ul style="list-style-type: none"> ● The unit is too hot. Stop using the unit for a while and let the unit cool down.

9. Help

9.3 When a function does not work, check here

If you still have difficulties after following the instructions in this section, reset the unit. To reset the unit, disconnect the power cord, then reconnect it.

9.3.1 Initial settings

Problem	Cause & Solution
I cannot hear a dial tone.	<ul style="list-style-type: none">• The telephone line cord is connected to the [EXT] jack on the unit. Connect to the [LINE] jack (page 4).• If you use a splitter to connect the unit, remove the splitter and connect the unit to the wall jack directly. If the unit operates properly, check the splitter.• Disconnect the unit from the telephone line and connect a known working telephone. If the working telephone operates properly, contact our service personnel to have the unit repaired. If the working telephone does not operate properly, contact your telephone company.• The power cord or telephone line cord is not connected. Check the connections.• If you connected the fax machine through a computer modem, connect the fax machine directly to a telephone line jack.
I cannot make calls.	<ul style="list-style-type: none">• The dialling mode setting may be wrong. Change the setting (feature #13 on page 11).
The unit does not ring.	<ul style="list-style-type: none">• The ringer volume is turned OFF. Adjust it (page 11).

9.3.2 General

Problem	Cause & Solution
The other party complains they only hear a fax tone and cannot talk.	<ul style="list-style-type: none">• FAX ONLY mode is set. Tell the other party the number is only used for faxes.• Change the receiving mode:<ul style="list-style-type: none">– KX-FT982: TEL mode (page 24) or TEL/FAX mode (page 25).– KX-FT988: TAM/FAX mode (page 25), TEL mode (page 24) or TEL/FAX mode (page 25).
During programming, I cannot enter the code or ID number.	<ul style="list-style-type: none">• All or part of the numbers are the same as another code or ID. Change the number:<ul style="list-style-type: none">– remote operation ID: feature #11 on page 33 (KX-FT988 only).– fax activation code: feature #41 on page 34.– auto disconnection: feature #49 on page 35.
The unit beeps.	<ul style="list-style-type: none">• The recording paper has run out. Press [STOP] to stop the beeps and install recording paper.
Caller information is not displayed.	<ul style="list-style-type: none">• You have not subscribed to Caller ID service.• The caller requested not to send his/her information.
While viewing caller information, the display returns to standby mode.	<ul style="list-style-type: none">• Do not pause for over 3 minutes while searching.
The speakerphone is not working. (KX-FT988 only)	<ul style="list-style-type: none">• Use the speakerphone in a quiet room.• If you have difficulty hearing the other party, adjust the volume.

9.3.3 Fax – sending

Problem	Cause & Solution
I cannot send documents.	<ul style="list-style-type: none"> • The telephone line cord is connected to the [EXT] jack on the unit. Connect to the [LINE] jack (page 4). • The other party's fax machine is busy or has run out of recording paper. Try again. • The other party does not have a fax machine. Check with the other party. • The other party's fax machine failed to answer the fax automatically. Send the fax manually (page 20).
I cannot send a fax overseas.	<ul style="list-style-type: none"> • Use the overseas transmission mode of feature #23 (page 33). • Add two pauses at the end of the telephone number or dial manually.
The other party complains that letters on their received document are distorted or not clear.	<ul style="list-style-type: none"> • If your line has special telephone services such as call waiting, the service may have been activated during fax transmission. Connect the unit to a line that does not have these services. • Another telephone on the same line is off the hook. Hang up the telephone and try again. • Try copying the document. If the copied image is clear, there may be something wrong with the other party's machine. • Adjust the scan contrast using feature #58 (page 35).
The other party complains that black lines, white lines or smudges appear on their received document.	<ul style="list-style-type: none"> • The scanner glass, white plate or rollers are dirty with correction fluid, etc. Clean them (page 45). Please do not insert a document before correction fluid has dried completely.

9.3.4 Fax – receiving

Problem	Cause & Solution
I cannot receive documents.	<ul style="list-style-type: none"> • The telephone line cord is connected to the [EXT] jack on the unit. Connect to the [LINE] jack (page 4). • The memory is full of received documents due to a lack of recording paper or a recording paper jam. Install paper (page 5) or clear the jammed paper (page 44).
I cannot receive documents automatically.	<ul style="list-style-type: none"> • The receiving mode is set to TEL mode. Change the receiving mode: <ul style="list-style-type: none"> – KX-FT982: FAX ONLY mode (page 26) or TEL/FAX mode (page 25). – KX-FT988: TAM/FAX mode (page 25), FAX ONLY mode (page 26) or TEL/FAX mode (page 25). • The time taken to answer the call is too long. Decrease the number of rings before the unit answers a call (feature #06 on page 32). • The greeting message is too long. Record a shorter message (page 29) (KX-FT988 only).
The display shows "CONNECTING", but faxes are not received.	<ul style="list-style-type: none"> • The receiving mode is set to FAX ONLY mode and the incoming call is not a fax. Change the receiving mode: <ul style="list-style-type: none"> – KX-FT982: TEL mode (page 24) or TEL/FAX mode (page 25). – KX-FT988: TAM/FAX mode (page 25), TEL mode (page 24) or TEL/FAX mode (page 25).
A blank sheet is ejected.	<ul style="list-style-type: none"> • The recording paper is not installed correctly. Make sure that the shiny side of the paper is facing down and re-install the paper (page 5). • The other party placed the document in their fax machine the wrong way. Check with the other party.

9. Help

Problem	Cause & Solution
The printing quality is poor.	<ul style="list-style-type: none"> • The thermal head is dirty. Clean it (page 45). • Adjust the print contrast using feature #59 (page 35). • If documents can be copied properly, the unit is working normally. The other party may have sent a faint document or there may be something wrong with the other party's machine. Ask them to send a clearer copy of the document or to check their fax machine.
The other party complains that they cannot send a document.	<ul style="list-style-type: none"> • The receiving mode is set to TEL mode. Receive the document manually (page 24) or change the receiving mode: <ul style="list-style-type: none"> – KX-FT982: FAX ONLY mode (page 26) or TEL/FAX mode (page 25). – KX-FT988: TAM/FAX mode (page 25), FAX ONLY mode (page 26) or TEL/FAX mode (page 25). • The memory is full of received documents due to a lack of recording paper or a recording paper jam. Install paper (page 5) or clear the jammed paper (page 44).
I cannot select the desired receiving mode.	<ul style="list-style-type: none"> • If you want to set TAM/FAX (KX-FT988 only) or FAX ONLY mode: <ul style="list-style-type: none"> – KX-FT982: Press [AUTO ANSWER] repeatedly to select FAX ONLY mode. – KX-FT988: Set the desired mode using feature #77 (page 35), and press [AUTO ANSWER] repeatedly to select the desired mode. • If you want to set TEL mode or TEL/FAX mode, set the desired mode using feature #73 (page 35), and press [AUTO ANSWER] repeatedly to select the desired mode.
When an extension telephone is connected, I cannot receive documents by pressing [*][#][9].	<ul style="list-style-type: none"> • You must set remote fax activation to ON (feature #41 on page 34) beforehand. • Press [*][#][9] firmly. • The memory is full of received documents due to a lack of recording paper or a recording paper jam. Install paper (page 5) or clear the jammed paper (page 44).

9.3.5 Copying

Problem	Cause & Solution
The unit will not make a copy.	<ul style="list-style-type: none"> • You cannot make a copy during programming. • You cannot make a copy during a telephone conversation.
A black line, a white line or smudge appears on the copied document.	<ul style="list-style-type: none"> • The scanner glass, white plate or rollers are dirty with correction fluid, etc. Clean them (page 45). Please do not insert a document before correction fluid has dried completely.
The copied document is blank.	<ul style="list-style-type: none"> • The recording paper is not installed correctly. Make sure that the shiny side of the paper is facing down and re-install the paper (page 5).
The copied image is distorted.	<ul style="list-style-type: none"> • Adjust the width of the document guides to fit the actual size of the document.
The printing quality is poor.	<ul style="list-style-type: none"> • The thermal head is dirty. Clean it (page 45). • Adjust the print contrast using feature #59 (page 35).

9.3.6 Answering machine (KX-FT988 only)

Problem	Cause & Solution
The answering machine is turned ON, but caller messages are not recorded.	<ul style="list-style-type: none"> ● The recording time is set to “GREETING ONLY”. Select “1 MINUTE”, “2 MINUTES” or “3 MINUTES” (feature #10 on page 33). ● The message memory is full. Erase unnecessary messages (page 30).
I cannot retrieve recorded messages from a remote location.	<ul style="list-style-type: none"> ● Activate the remote operation feature by setting the remote operation ID beforehand (feature #11 on page 33). ● Press the remote operation ID correctly and firmly (page 31). ● The unit is not in TAM/FAX mode. Change to TAM/FAX mode (page 25).
The other party complains that they cannot leave a voice message.	<ul style="list-style-type: none"> ● The memory is full. Erase unnecessary messages (page 30). ● The recording time is set to “GREETING ONLY”. Select “1 MINUTE”, “2 MINUTES” or “3 MINUTES” (feature #10 on page 33).
While recording a greeting message or listening to messages, the unit rings and recording stops.	<ul style="list-style-type: none"> ● A call is being received. Answer the call and try again later.

9.3.7 If a power failure occurs

- The unit will not function.
- The unit is not designed for making emergency telephone calls when the power fails. Alternative arrangements should be made for access to emergency services.
- Fax transmission and reception will be interrupted.
- If delayed transmission (feature #25 on page 33) is programmed and power failure prevents the document from being sent at the set time, the transmission may be cancelled.
- If any fax documents are stored in the memory, they will be lost. When power is restored, a power down report will be printed stating which documents in memory have been erased.
- The date and time setting may be lost. If the correct date and time is not displayed after the power has been restored, set the date and time again (page 11).

10.1 Recording paper jams

- 1 Open the top cover by pressing the top cover release button (①).

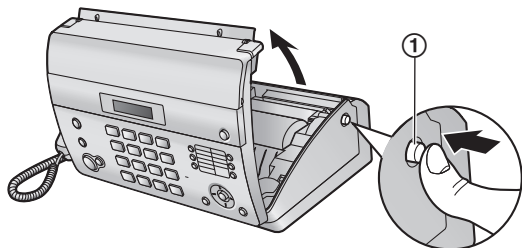

- 2 For KX-FT982:

Skip to step 3.

For KX-FT988:

Pull the cutter release lever (①) forward.

- The paper cutter will be released.

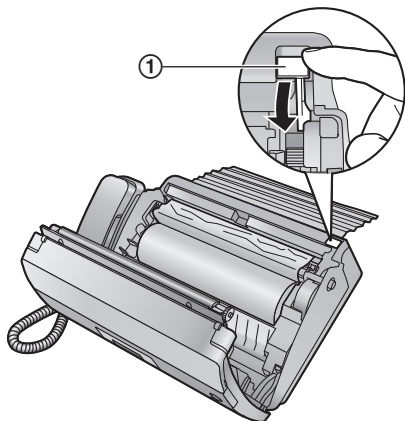

- 3 Remove the recording paper.

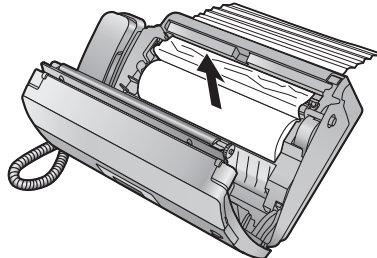

- 4 Cut off the wrinkled portion.

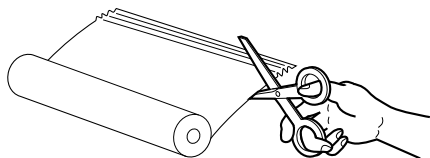

- 5 Install the recording paper and close the top cover securely by pushing down on both sides (see page 5 for details).



Note:

- Make sure the paper stacker is inserted (page 4) (KX-FT988 only).

10.2 Document jams – sending

- 1 Open the top cover by pressing the top cover release button (①) and remove the jammed document carefully (②).

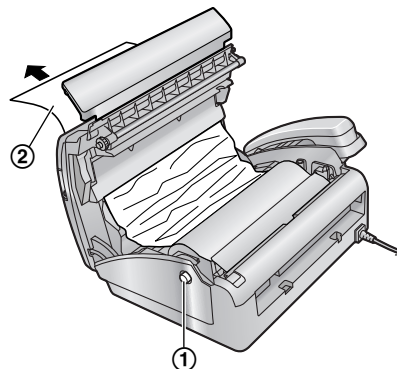

- 2 Close the top cover securely by pushing down on both sides, then press **[FAX/START]**.

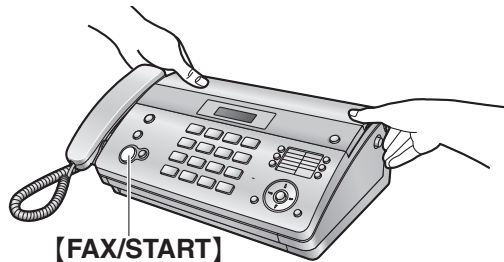

Note:

- Do not pull out the jammed paper forcibly before opening top cover.



10.3 Document feeder / scanner glass cleaning

Clean the document feeder when:

- Documents frequently misfeed.
- Smudges or black/white lines appear on the document when sending or copying.

- 1 Disconnect the power cord and the telephone line cord.
- 2 Open the top cover by pressing the top cover release button (①).

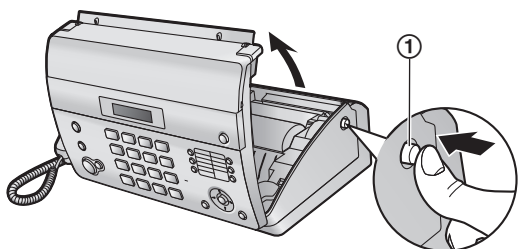

- 3 Clean the document feeder rollers (①) and rubber flap (②) with a cloth moistened with isopropyl rubbing alcohol, and let all parts dry thoroughly. Clean the white plate (③) and scanner glass (④) with a soft and dry cloth.

Caution:

- Do not use paper products, such as paper towels or tissues.

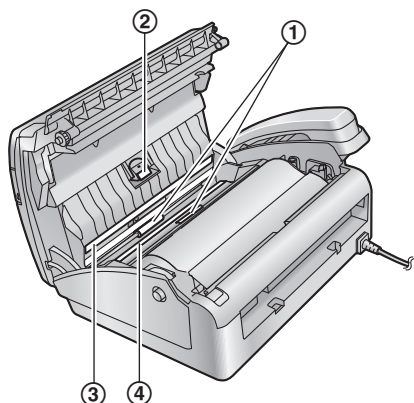

- 4 Connect the power cord and the telephone line cord.
- 5 Close the top cover securely by pushing down on both sides, then press **[FAX/START]**.

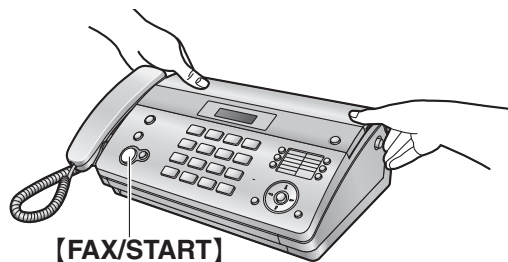

10.4 Thermal head cleaning

If smudges or black/white lines appear on a copied/received document, check whether there is dust on the thermal head. Clean it to remove the dust.

- 1 Disconnect the power cord and the telephone line cord.
- 2 Open the top cover by pressing the top cover release button (①) and remove the recording paper.

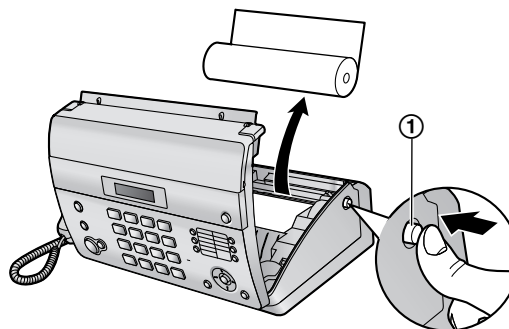

- 3 Clean the thermal head (①) with a cloth moistened with isopropyl rubbing alcohol, and let all parts dry thoroughly.

Caution:

- To prevent a malfunction due to static electricity, do not use a dry cloth and do not touch the thermal head directly.

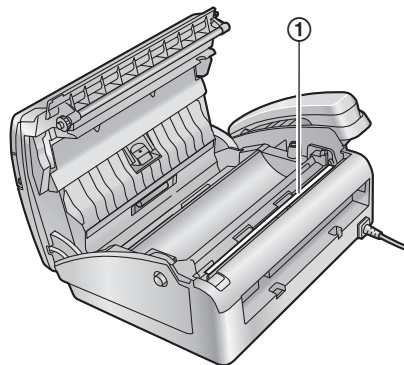

- 4 Connect the power cord and the telephone line cord.
- 5 Install the recording paper and close the top cover securely by pushing down on both sides (see page 5 for details).



11. General Information

11.1 Reference lists and reports

You can print out the following lists and reports for your reference.

Setup list:

provides you with the current settings of the programming features (page 32 to page 36).

Telephone number list:

provides you with names and numbers which are stored in the phonebook and one-touch dial feature.

Journal report:

keeps records of fax transmission and reception. This report can be printed automatically after every 30 fax communications (feature #22 on page 33).

Broadcast programming list:

provides you with names and numbers which are stored in the broadcast memory (page 22).

Printer test:

allows you to check the print quality of your unit. If the test print has a smudge, or blurred points or lines, clean the thermal head (page 45).

Caller ID list:

keeps records of the last 30 different callers after subscribing to a Caller ID service. To print automatically after every 30 callers, activate feature #26 (page 34).



[STOP] **[◀][▶] [SET] [MENU]**

- 1 Press **[MENU]** repeatedly to display “**PRINT REPORT**”.
- 2 Press **[◀]** or **[▶]** repeatedly to display the desired item.
- 3 Press **[SET]** to start printing.
 - To stop printing, press **[STOP]**.
- 4 Press **[MENU]**.

11.2 Specifications

■ Applicable lines:

Public Switched Telephone Network

■ Document size:

Max. 216 mm in width, Max. 600 mm in length

■ Effective scanning width:

208 mm

■ Recording paper size:

216 mm × max. 30 m roll

■ Effective printing width:

208 mm

■ Transmission time^{*1}:

Approx. 15 s/page (Original mode)^{*2}

■ Scanning density:

Horizontal: 8 pels/mm

Vertical: 3.85 lines/mm – in standard resolution,

7.7 lines/mm – in fine/photo resolution,

15.4 lines/mm – in super fine resolution

■ Photo resolution:

64-level

■ Scanner type:

Contact Image Sensor

■ Printer type:

Thermal printing

■ Data compression system:

Modified Huffman (MH), Modified READ (MR)

■ Modem speed:

9,600 / 7,200 / 4,800 / 2,400 bps; Automatic Fallback

■ Operating environment:

5 °C – 35 °C, 20 % – 80 % RH (Relative Humidity)

■ Dimensions:

Approx.: height 121 mm × width 352 mm × depth 224 mm

■ Mass (Weight):

KX-FT982: Approx. 2.7 kg

KX-FT988: Approx. 2.8 kg

■ Power consumption:

Standby: Approx. 1.5 W (KX-FT982)

Standby: Approx. 1.8 W (KX-FT988)

Transmission: Approx. 13 W

Reception: Approx. 30 W (When receiving a 20 % black document)

Copy: Approx. 35 W (When copying a 20 % black document)

Maximum: Approx. 110 W (When copying a 100 % black document)

■ Power supply:

220 V – 240 V AC, 50/60 Hz

■ Fax memory capacity^{*3}:

Approx. 28 pages of memory reception
(Based on the ITU-T No. 1 Test Chart in standard resolution, with original mode.)

■ Voice memory capacity^{*4} (KX-FT988 only):

Approx. 12 minutes of recording time including greeting message when no documents are in memory

*1 Transmission speed depends upon the contents of the pages, resolution, telephone line conditions and capability of the other party's machine.

*2 Transmission speed is based upon the ITU-T No. 1 Test Chart with original mode. If the capability of the other party's machine is inferior to your unit, the transmission time may be longer.

*3 If an error occurs during fax reception, such as a paper jam or if the recording paper runs out, the fax and subsequent faxes will be retained in memory.

*4 Recording time may be reduced by the calling party's background noise.

ITU-T No. 1 Test Chart

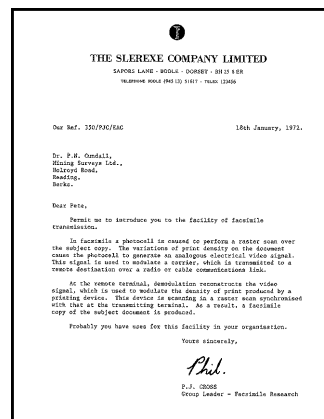

Note:

- Design and specifications are subject to change without notice.
- The pictures and illustrations in these instructions may vary slightly from the actual product.
- The suffix in the model number will be omitted in these instructions.
- Most figures shown in these operating instructions are based on a KX-FT982.

11. General Information

11.3 Character entry

The dial keys are used to enter characters and numbers. Each dial key has multiple characters assigned to it. The available character entry modes are Alphabet (ABC), Numeric (0-9), Greek (ABΓ), Extended 1 (AÄÅ), Extended 2 (ŠŠš), and Cyrillic (АБВ). When in these entry modes except Numeric, you can select which character is entered by pressing a dial key repeatedly.

- Press [◀] or [▶] to move the cursor.
- Press dial keys to enter characters and numbers.
- Press [STOP] to erase the character or number highlighted by the cursor. Press and hold [STOP] to erase all characters or numbers.
- Press [✳] to switch between uppercase and lowercase.
- To enter another character located on the same dial key, press [▶] to move the cursor to the next space, then press the appropriate dial key.

11.3.1 Character entry modes

Several character entry modes can be used when entering text. The characters that can be entered depend on the entry mode.

11.3.2 Characters available in each character entry mode

When the unit displays the character entry screen:

Press [⇄] repeatedly to select a character entry mode.

Alphabet character table (ABC)

[0]	[1]	[2]	[3]	[4]	[5]	[6]	[7]	[8]	[9]
Space	Space #	A B C	D E F	G H I	J K L	M N O	P Q R S	T U V	W X Y Z
0	& ' () *	2	3	4	5	6	7	8	9
	, - . / 1	a b c	d e f	g h i	j k l	m n o	p q r s	t u v	w x y z
		2	3	4	5	6	7	8	9

Numeric entry table (0-9)

[0]	[1]	[2]	[3]	[4]	[5]	[6]	[7]	[8]	[9]
0	1	2	3	4	5	6	7	8	9

Greek character table (ABΓ)

[0]	[1]	[2]	[3]	[4]	[5]	[6]	[7]	[8]	[9]
Space	Space #	A B Γ	Δ E Z	H Θ I	K Λ M	N Ξ O	Π P Σ	T Υ Φ	X Ψ Ω Ξ
0	& ' () *	2	3	4	5	6	7	8	9
	, - . / 1								

Extended 1 character table (AÄÅ)

[0]	[1]	[2]	[3]	[4]	[5]	[6]	[7]	[8]	[9]
Space	Space #	A Ä Å	D E È	G Ğ H	J K L	M N Ñ	P Q R S	T U Û	W Ŵ X
0	& ' () *	Ä Å Ä	É Ê Ë	Ì Í Î	5	Ö Õ Ó	Ş ß 7	Ú Û Ü	Ý Ŷ Z 9
	, - . / 1	Å Æ B	Ë F 3	Ï Ñ Ñ		Ô Õ Ö		Û V 8	
		C Ç 2		4		ø 6			
		a à á	d e è	g ğ h	j k l 5	m n ñ	p q r s	t u ù	w Ŵ x
		â ä å	é ê ë	ì í î ï		o ò ó	ş ß 7	ú û ü	y ŷ z 9
		ã æ b	ë f 3	ı ï ï 4		ô õ ö		ü v 8	
		c ç 2				ø 6			

- The following are used for both uppercase and lowercase: ø Ş Ŵ Ŷ

Extended 2 character table (ŠŠŠ)

[0]	[1]	[2]	[3]	[4]	[5]	[6]	[7]	[8]	[9]
Space 0	Space # & ' () * , - . / 1	A Á Â À Á Â Ā Ā Ā Ĉ Ĉ Ĉ 2	D Ď E É Ě Ě F 3	G H I Í 4	J K L Ĺ Ĺ Ĺ 5	M N Ń Ń Ó Ó Ŕ Ŕ Ŕ Ŗ Ŗ Ŗ 7	P Q R Ŕ Ŕ Ŕ Ŕ Ŕ Ŕ Ŕ Ŕ Ŕ Ŕ Ŕ Ŕ Ŕ 7	T Ť U Ú Ů Ů ů V 8	W X Y ŷ Ý Z Ž Ž Ž 9
		a á â À Á Â Ā Ā Ā Ĉ Ĉ Ĉ 2	d ě e é Ě Ě f 3	g h i í 4	j k l ĺ Ĺ Ĺ 5	m n Ń ň ó ó ŕ s Š Š š š š š 7	p q r Ŕ Ŕ Ŕ Ŕ Ŕ Ŕ Ŕ Ŕ Ŕ Ŕ Ŕ Ŕ Ŕ 7	t ť u ú ú Ů Ů ů V 8	w x y ŷ Ý Z Ž Ž Ž 9

- The following are used for both uppercase and lowercase:

À Ā Ĉ Ě Ĺ Ĺ Ń Ŕ Š Š ŷ ŷ Ž Ž Ž

Cyrillic character table (АБВ)

[0]	[1]	[2]	[3]	[4]	[5]	[6]	[7]	[8]	[9]
Space 0 Ğ € I İ ŷ	Space # & ' () * , - . / 1	А Б В Г 2	Д Е Ж З 3	И Й К Л 4	М Н О П 5	Р С Т У 6	Ф Х Ц Ч 7	Ш Щ Ъ Ы 8	Ь Э Ю Я 9

11.4 Useful information

User record (for your future reference)

Date of purchase
Serial number (found on the rear of the unit)
Dealer's name and address
Dealer's telephone number

Attach your sales receipt here.



Notice for product disposal, transfer, or return

- This product can store your private/confidential information. To protect your privacy/confidentiality, we recommend that you erase the information such as phonebook or caller information from the memory before you dispose, transfer or return the product.

12.1 Index

- # #01 Date and time: 11
- #02 Your logo: 12
- #03 Your fax number: 13
- #04 Sending report: 20, 32
- #06 FAX ring count: 32
- #06 TAM ring count: 26, 33
- #10 Message recording time: 33
- #11 Remote operation ID: 33
- #13 Dialling mode: 11, 33
- #17 Ringer Tone: 33
- #22 Automatic journal report: 20, 33
- #23 Overseas mode: 33
- #25 Delayed transmission: 33
- #26 Automatic Caller ID list: 34
- #36 Receiving reduction: 34
- #39 Display contrast: 34
- #41 Fax activation code: 34
- #44 Memory reception alert: 34
- #46 Friendly reception: 34
- #47 Voice guidance: 34
- #48 Language: 34
- #49 Auto disconnection: 35
- #54 Greeting Recording time: 35
- #58 Scan contrast: 35
- #59 Print contrast: 35
- #67 Incoming message monitor: 35
- #72 Recall/flash time: 35
- #73 Manual answer mode: 35
- #74 Location: 35
- #76 Connecting tone: 35
- #77 Auto answer: 35
- #78 TEL/FAX ring setting: 36
- #80 Set default: 36
- A** Accessories: 4
 - Advanced features: 33
 - Auto answer setting: 35
 - Auto Disconnection: 35
- B** Basic features: 32
 - Broadcast transmission: 22
- C** Caller ID: 16
 - Calling back: 16
 - Storing: 18
 - Caller ID list: 16, 34, 46
 - Caller's recording time: 33
 - Character entry: 48
 - Cleaning: 45
 - Connecting tone: 35
 - Connections: 4
 - Copy: 28
- D** Date and time: 11
 - Delayed transmission: 33
 - Dialling mode: 11, 33
 - Display
 - Contrast: 34
 - Error messages: 38
 - Document size: 20
- E** Error messages: 38
 - Extension telephone: 24
- F** Fax activation code: 34
 - Fax number: 13
 - FAX ONLY mode: 23, 26
 - Flash time: 35
 - Friendly reception: 34
- I** Incoming message monitor: 35
- J** Jams
 - Document: 44
 - Recording paper: 44
 - Journal report: 20, 33
 - Junk fax prohibitor: 27
- L** Language: 34
 - Location setting: 35
 - Logo: 12
- M** Manual answer setting: 35
 - Memory reception alert: 34
- O** One-touch dial: 15, 19, 21
 - Overseas mode: 33
- P** Phonebook
 - Editing: 14
 - Erasing: 14
 - Making a phone call: 14
 - Sending faxes: 21
 - Storing: 14
 - Polling: 26
 - Power failure: 43
 - Print contrast: 35
 - Programming: 32

-
- R** Recall time: 35
 - Receiving faxes
 - Automatically: 25
 - Manually: 24
 - Receiving reduction: 34
 - Recording paper: 5
 - Redialling: 20, 21
 - Remote operation ID: 33
 - Reports
 - Broadcast programming: 46
 - Broadcast sending: 22
 - Caller ID list: 16, 34, 46
 - Journal: 20, 33, 46
 - Power down: 43
 - Printer test: 46
 - Sending: 20, 32
 - Setup: 46
 - Telephone number: 46
 - Reset: 36, 40
 - Resolution: 20, 28
 - Ringer tone: 33
 - Ring setting
 - FAX ONLY: 32
 - TAM/FAX: 33
 - TEL/FAX: 35
 - S** Scan contrast: 35
 - Sending faxes
 - Broadcast: 22
 - Manually: 20
 - Phonebook: 21
 - Sending report: 20, 32
 - Storing
 - Broadcast: 22
 - One-touch dial: 15
 - Phonebook: 14
 - T** TAM/FAX mode: 23, 25
 - TEL/FAX mode: 24, 25
 - TEL mode: 23, 24
 - V** Voice guidance: 34
 - Volume: 11

CE 0682

Declaration of Conformity:

- Panasonic System Networks Co., Ltd. declares that this equipment is in compliance with the essential requirements and other relevant provisions of Radio & Telecommunications Terminal Equipment (R&TTE) Directive 1999/5/EC. Declarations of Conformity for the relevant Panasonic products described in this manual are available for download by visiting:
<http://www.doc.panasonic.de>

Contact to Authorised Representative:

Panasonic Testing Centre
Panasonic Marketing Europe GmbH
Winsbergring 15, 22525 Hamburg, Germany

Manufacturer:

Panasonic System Networks Co., Ltd.
1-62, 4-chome, Minoshima, Hakata-ku, Fukuoka 812-8531, Japan

Global web site:

<http://panasonic.net>

Copyright:

- This material is copyrighted by Panasonic System Networks Co., Ltd., and may be reproduced for internal use only. All other reproduction, in whole or in part, is prohibited without the written consent of Panasonic System Networks Co., Ltd.

© Panasonic System Networks Co., Ltd. 2008



FT982FX

PNQX1439YB FM0708YK2050

1/3